



**Cambridge International Examinations**  
Cambridge International General Certificate of Secondary Education

**CO-ORDINATED SCIENCES**

**0654/23**

Paper 2 Multiple Choice (Extended)

**October/November 2018**

**45 minutes**

Additional Materials: Multiple Choice Answer Sheet  
Soft clean eraser  
Soft pencil (type B or HB is recommended)



**READ THESE INSTRUCTIONS FIRST**

Write in soft pencil.

Do not use staples, paper clips, glue or correction fluid.

Write your name, Centre number and candidate number on the Answer Sheet in the spaces provided unless this has been done for you.

**DO NOT WRITE IN ANY BARCODES.**

There are **forty** questions on this paper. Answer **all** questions. For each question there are four possible answers **A, B, C** and **D**.

Choose the **one** you consider correct and record your choice in **soft pencil** on the separate Answer Sheet.

**Read the instructions on the Answer Sheet very carefully.**

Each correct answer will score one mark. A mark will not be deducted for a wrong answer.

Any rough working should be done in this booklet.

A copy of the Periodic Table is printed on page 16.

Electronic calculators may be used.

This document consists of **15** printed pages and **1** blank page.

- 1 One way to test for microscopic life in soil is to see if carbon dioxide is released.

Which characteristic of living things is being tested?

- A growth
- B nutrition
- C reproduction
- D respiration

- 2 The diagram shows a red blood cell. If it is placed in water, it will burst. If a plant cell is placed in water, it will not burst.

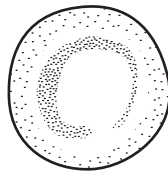

What prevents a plant cell from bursting?

- A cell wall
- B nucleus
- C regular shape
- D vacuole

- 3 The diagram shows four test-tubes in beakers at different temperatures.

Each test-tube contains the same amount of starch suspension. Equal amounts of salivary amylase are added to each test-tube.

After 20 minutes, which test-tube will contain the most reducing sugar?

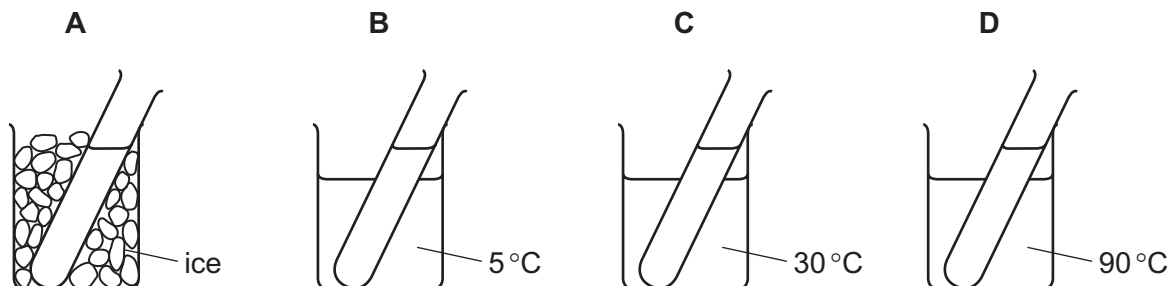

- 4 What traps light energy during photosynthesis?

- A chlorophyll
- B glucose
- C nitrate ions
- D water

5 Water is taken in through the roots and lost from the leaves of tall trees.

What enables this to happen?

- A active transport by the xylem vessels
- B pressure from the roots
- C translocation in the phloem
- D transpiration loss from the leaves

6 The diagram shows the structure of a villus.

Which structure absorbs and carries away amino acids?

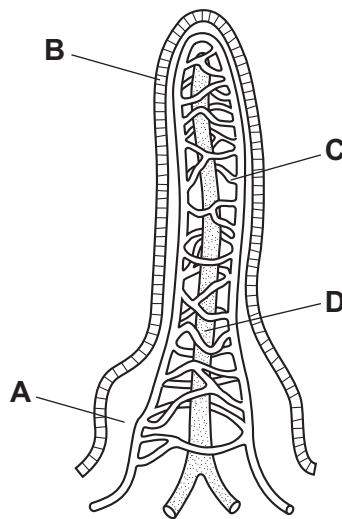

7 What is an effect of carbon monoxide on the gas exchange system?

- A It causes lung cancer.
- B It causes the alveoli to stick together.
- C It slows down the diffusion of carbon dioxide through the alveoli.
- D It stops oxygen from combining with haemoglobin.

8 To which environmental stimulus is a plant root responding when it grows downwards?

- A a decrease in soil water content
- B light falling on the leaves of the plant
- C rising temperature
- D the force of gravity

9 What is an advantage of asexual reproduction compared with sexual reproduction?

- A A specific disease is less likely to spread throughout the whole population.
- B It increases variation in the offspring.
- C It produces offspring more rapidly.
- D It requires two parents.

10 Which part of a flower produces pollen grains?

- A anther
- B ovary
- C sepal
- D stigma

11 In pea plants, the allele for purple flowers is dominant to the allele for white flowers.

Two heterozygous purple-flowered plants are crossed.

What will be the expected flower colour of the offspring plants?

- A all purple
- B all white
- C 1 purple : 1 white
- D 3 purple : 1 white

12 Some strains of bacteria developed resistance to certain antibiotics.

What does this **not** involve?

- A artificial selection
- B mutation
- C natural selection
- D survival of the fittest

13 The diagram shows part of the carbon cycle.

Which arrow represents plant respiration?

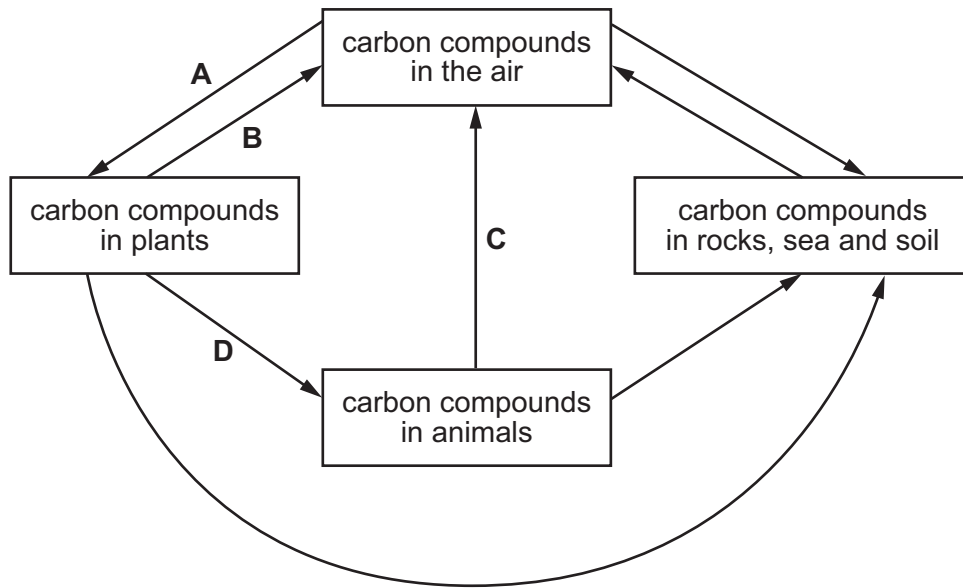

14 W, X, Y and Z are diagrams representing atoms and molecules.

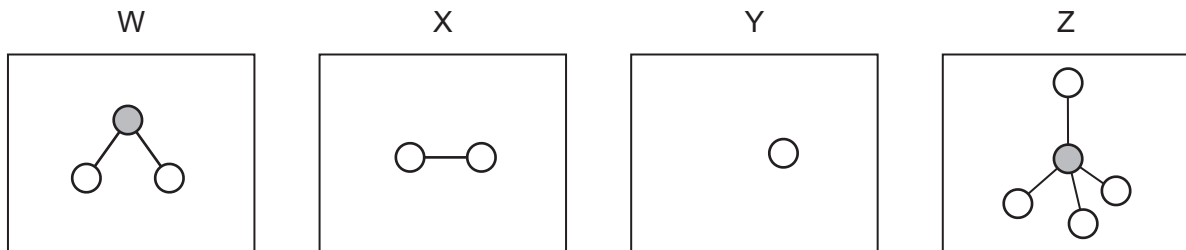

Which statement is correct?

- A W and Z are molecules and X and Y are atoms.
- B W, X and Z are molecules and Y is an atom.
- C W, Y and Z are molecules and X is an atom.
- D X, Y and Z are molecules and W is an atom.

15 Hexane and octane are liquid hydrocarbons that mix together.

Which apparatus is used to separate a mixture of these two liquids?

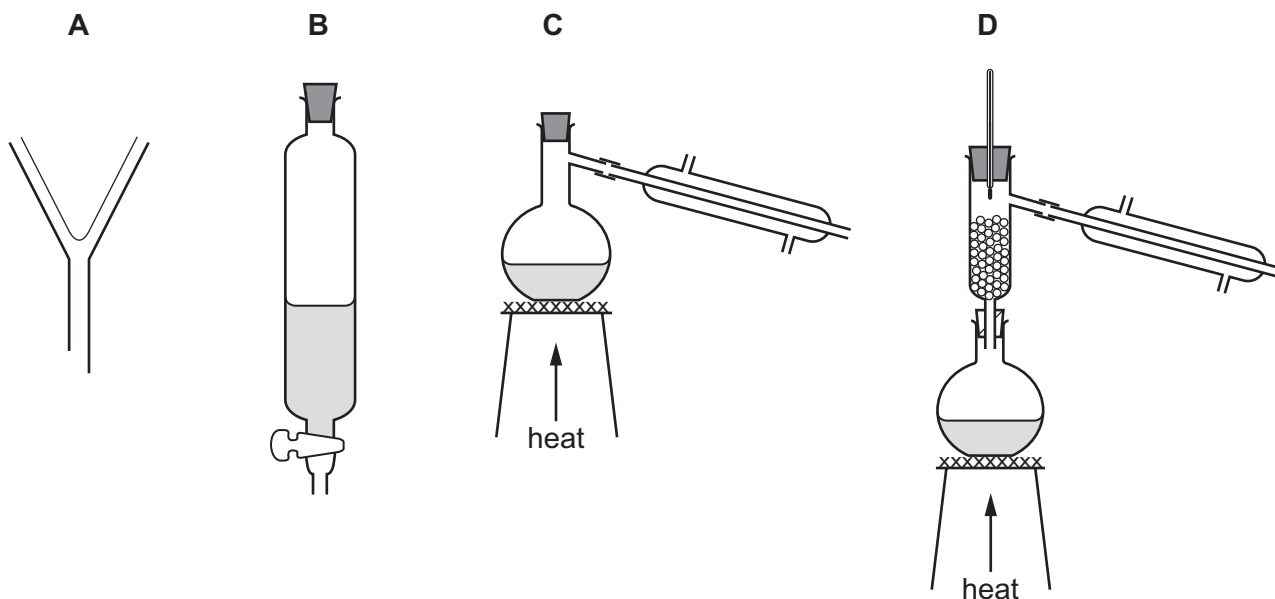

16 Which dot-and-cross diagram is **not** correct?

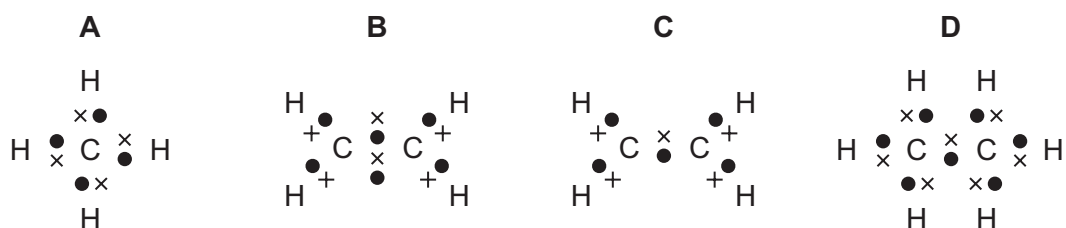

17 Which sample of gas contains the most molecules?

- A 2 g of hydrogen,  $\text{H}_2$
- B 48 g of oxygen,  $\text{O}_2$
- C 56 g of nitrogen,  $\text{N}_2$
- D 64 g of sulfur dioxide,  $\text{SO}_2$

18 Which substance does **not** undergo electrolysis?

- A aqueous copper chloride
- B copper wire
- C dilute sulfuric acid
- D molten lead(II) bromide

19 Solid sodium hydroxide reacts with dilute hydrochloric acid.

Which change shows that the reaction is exothermic?

- A A gas is produced.
- B The mass increases.
- C The pH increases.
- D The temperature increases.

20 Iron oxide reacts with carbon monoxide.

The word equation is



Which statement describes what happens to the iron oxide?

- A It is oxidised because it gains oxygen.
- B It is oxidised because it loses oxygen.
- C It is reduced because it gains oxygen.
- D It is reduced because it loses oxygen.

21 Aqueous solutions of oxides X, Y and Z are tested using Universal Indicator.

Oxide X turns the indicator red.

Oxide Y turns the indicator blue.

Oxide Z turns the indicator green.

Which row describes these three substances?

	X	Y	Z
A	acidic	basic	basic
B	acidic	basic	neutral
C	basic	acidic	acidic
D	basic	acidic	neutral

22 A block of zinc is attached to an underground steel pipe as shown.

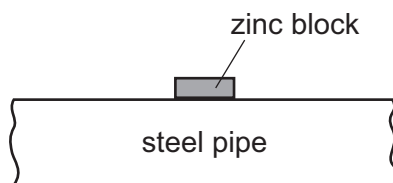

The zinc stops the steel rusting by sacrificial protection.

Which statement does **not** explain how sacrificial protection works?

- A Zinc is more reactive than the iron in steel.
- B Zinc is oxidised in preference to the iron in steel.
- C Zinc prevents oxygen from reaching the steel.
- D Zinc transfers electrons to the iron in the steel.

23 Which process takes place in the catalytic converter of a car exhaust?

- A oxidation of carbon dioxide to carbon monoxide
- B oxidation of sulfur to sulfur dioxide
- C reduction of hydrocarbons to carbon dioxide and water
- D reduction of oxides of nitrogen to nitrogen

24 The diagram shows gas P being passed through liquid X and over iron filings.

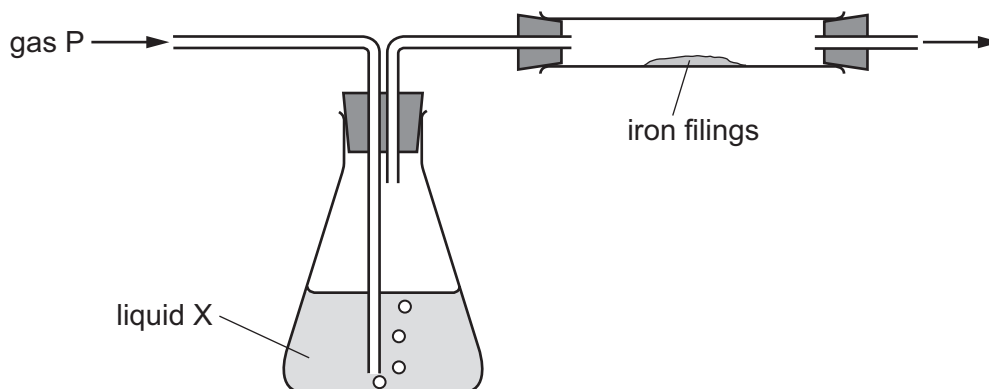

Which gas and liquid cause the iron to rust?

	gas P	liquid X
<b>A</b>	nitrogen	concentrated sulfuric acid (a drying agent)
<b>B</b>	nitrogen	water
<b>C</b>	oxygen	concentrated sulfuric acid (a drying agent)
<b>D</b>	oxygen	water



25 Sulfuric acid is manufactured by the Contact process.

Which conditions are used in this process?

- A 2 atmospheres pressure and a vanadium pentoxide catalyst
- B 2 atmospheres pressure and an iron catalyst
- C 200 atmospheres pressure and a vanadium pentoxide catalyst
- D 200 atmospheres pressure and an iron catalyst

26 Ethene is manufactured from alkanes.

Ethene is used to manufacture ethanol.

Which statement about these processes is **not** correct?

- A Ethanol is made by reacting ethene with oxygen.
- B Ethene is converted to ethanol by an addition reaction.
- C Ethene is made by cracking.
- D The manufacture of ethanol uses a catalyst.

27 The molecule shown contains some amide linkages.

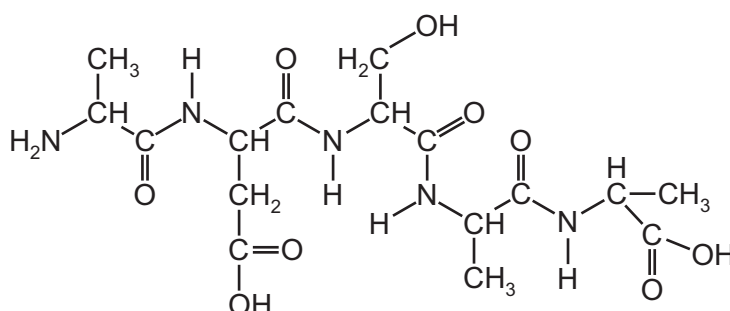

How many amide linkages are present in this molecule?

- A 4
- B 6
- C 7
- D 9

28 The diagrams show the speed-time graphs for four objects.

Which object travels the greatest distance?

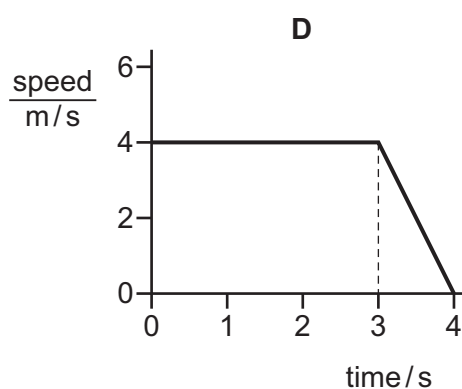
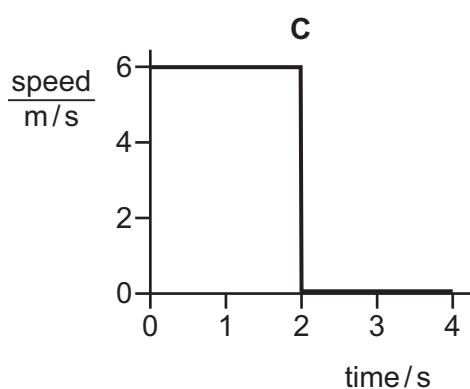
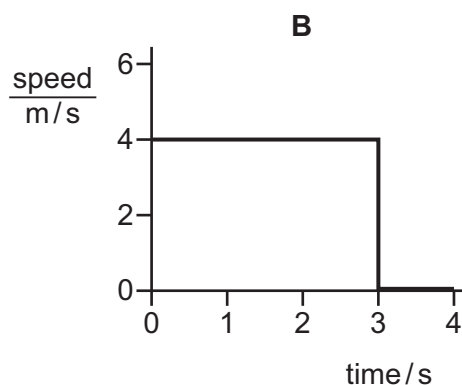
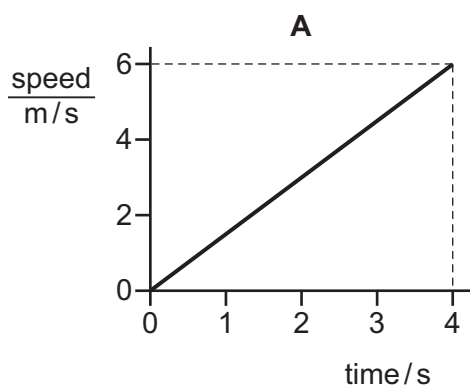

29 What is the difference, if any, between the terms *speed* and *velocity*?

- A** None. They have the same meaning.
- B** Speed is velocity with a direction.
- C** Velocity is rate of change of speed.
- D** Velocity is speed with a direction.

30 A pole-vaulter of mass 60 kg rises to a maximum height of 5.0 m and then falls to the ground.

The acceleration of free fall  $g$  is  $10 \text{ m/s}^2$ . Air resistance can be ignored.

At what speed does the pole-vaulter hit the ground when she falls?

- A** 5.0 m/s
- B** 10 m/s
- C** 25 m/s
- D** 100 m/s

- 31 An axle is slightly larger than the hole in a wheel made from the same metal.

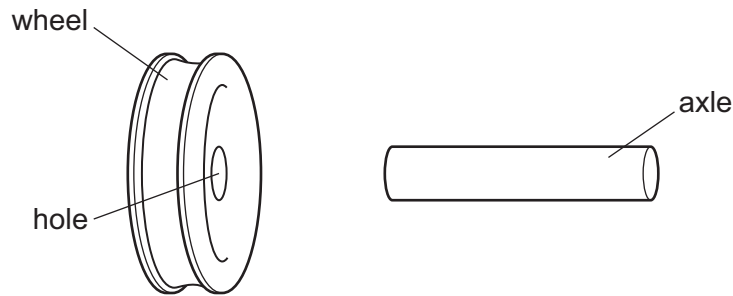

How could an engineer fit the wheel onto the axle?

- A cool the axle only
  - B cool the axle and cool the wheel by the same temperature change
  - C heat the axle only
  - D heat the axle and heat the wheel by the same temperature change
- 32 There is a vacuum between the double walls of a vacuum flask.
- Which types of heat transfer are reduced by the vacuum?
- A conduction, convection and radiation
  - B conduction and convection only
  - C conduction and radiation only
  - D convection and radiation only
- 33 A radio transmitter emits radio waves with a frequency of  $1.25 \times 10^8$  Hz. The most suitable aerial for this frequency is  $\frac{1}{4}$  of a wavelength long.

The speed of radio waves is  $3.0 \times 10^8$  m/s.

What is the length of the most suitable aerial?

- A 0.10 m
- B 0.60 m
- C 2.4 m
- D 9.6 m

- 34 The ray diagram shows two rays of light that have passed from an object through a converging lens.

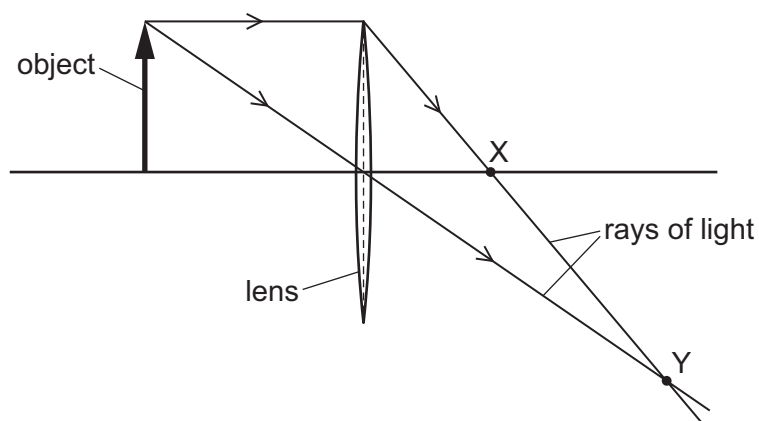

Which labelled point X or Y is a principal focus of the lens, and how does the size of the image compare with the size of the object?

	principal focus	size of image
<b>A</b>	X	larger than object
<b>B</b>	X	smaller than object
<b>C</b>	Y	larger than object
<b>D</b>	Y	smaller than object

- 35 Which statement about sound is correct?

- A** Sound travels fastest through solids.
- B** Sound travels fastest through liquids.
- C** Sound travels fastest through gases.
- D** Sound travels fastest through a vacuum.

- 36 What is the unit of charge and what is an equivalent combination of units?

	unit	equivalent combination
<b>A</b>	ampere	coulomb second
<b>B</b>	ampere	volt ohm
<b>C</b>	coulomb	ampere / second
<b>D</b>	coulomb	ampere second

37 Which diagram shows the pattern of the magnetic field lines around a bar magnet?

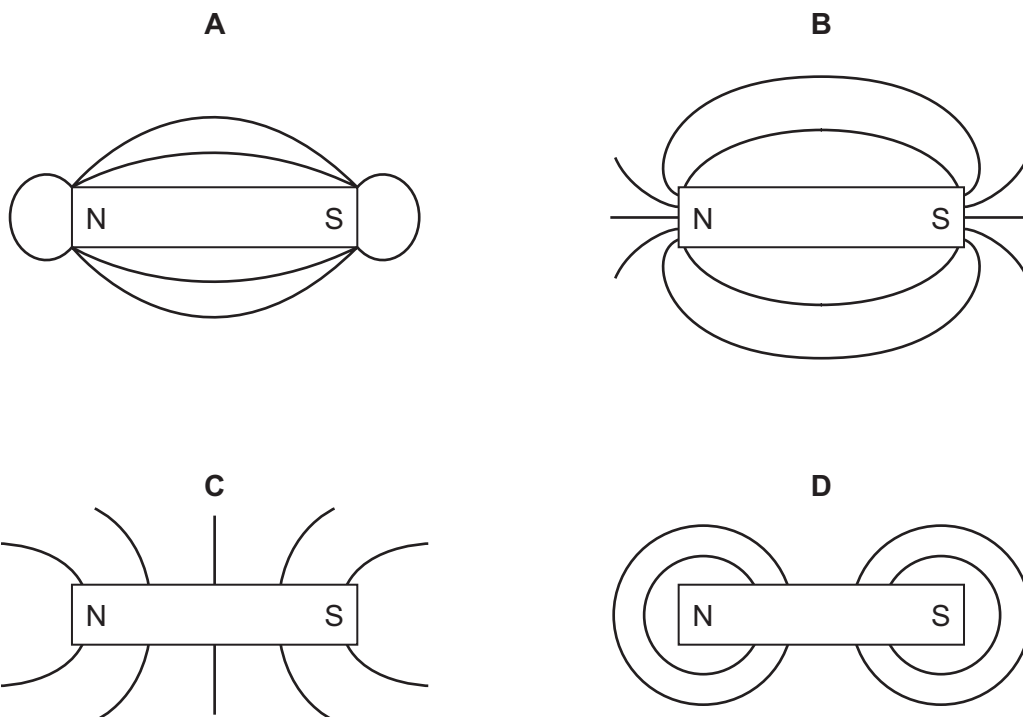

38 A circuit contains a lamp and a fuse.

There is a current of 2.0 A in the lamp and it operates normally.

A fault develops in the lamp. The current in the circuit increases, and the fuse now blows.

The diagrams show two circuits.

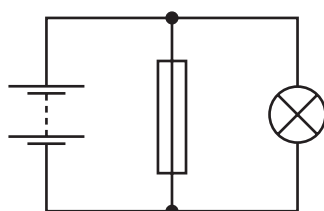

diagram 1

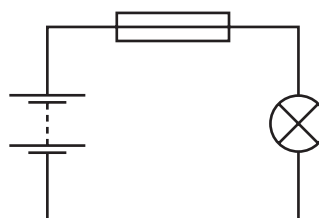
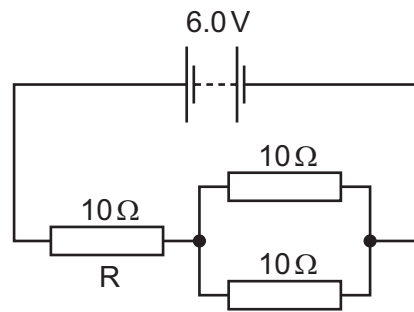

diagram 2

Which is the circuit used and what is the effect of the fuse when it blows?

	circuit	effect of fuse
<b>A</b>	diagram 1	reduces current to 0
<b>B</b>	diagram 1	reduces current to 2.0 A
<b>C</b>	diagram 2	reduces current to 0
<b>D</b>	diagram 2	reduces current to 2.0 A

- 39 A 6.0V battery is connected to three  $10\Omega$  resistors, as shown. One resistor is labelled R.



What is the current in resistor R?

- A 0.20A      B 0.40A      C 0.60A      D 1.8A
- 40 The diagram shows a d.c. motor. The switch is open.

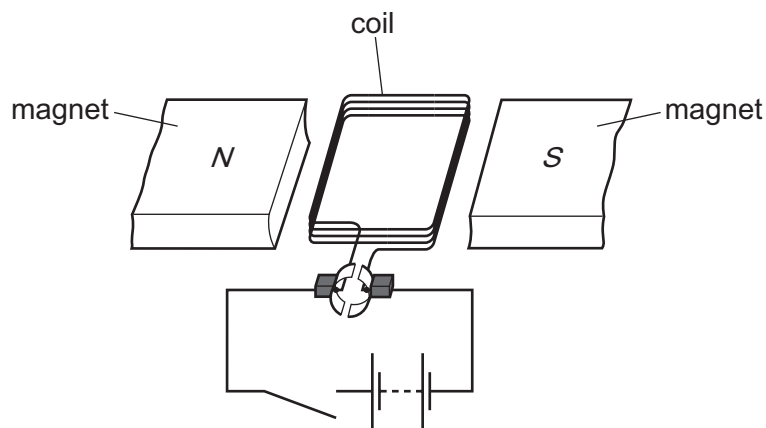

Four statements, P, Q, R and S, each partly explain what happens when the switch closes.

- P A current is produced in the coil.  
 Q The coil begins to rotate.  
 R The coil experiences a force.  
 S The battery produces a potential difference across the coil.

What is the correct order for these statements to explain how the motor works?

- A  $P \rightarrow S \rightarrow Q \rightarrow R$   
 B  $P \rightarrow S \rightarrow R \rightarrow Q$   
 C  $S \rightarrow P \rightarrow Q \rightarrow R$   
 D  $S \rightarrow P \rightarrow R \rightarrow Q$

**BLANK PAGE**

---

Permission to reproduce items where third-party owned material protected by copyright is included has been sought and cleared where possible. Every reasonable effort has been made by the publisher (UCLES) to trace copyright holders, but if any items requiring clearance have unwittingly been included, the publisher will be pleased to make amends at the earliest possible opportunity.

To avoid the issue of disclosure of answer-related information to candidates, all copyright acknowledgements are reproduced online in the Cambridge International Examinations Copyright Acknowledgements Booklet. This is produced for each series of examinations and is freely available to download at [www.cie.org.uk](http://www.cie.org.uk) after the live examination series.

Cambridge International Examinations is part of the Cambridge Assessment Group. Cambridge Assessment is the brand name of University of Cambridge Local Examinations Syndicate (UCLES), which is itself a department of the University of Cambridge.

## The Periodic Table of Elements

Group																			
I	II											III	IV	V	VI	VII	VIII		
										1 H hydrogen 1							2 He helium 4		
		<b>Key</b> atomic number atomic symbol name relative atomic mass										5 B boron 11	6 C carbon 12	7 N nitrogen 14	8 O oxygen 16	9 F fluorine 19	10 Ne neon 20		
3 Li lithium 7	4 Be beryllium 9											13 Al aluminium 27	14 Si silicon 28	15 P phosphorus 31	16 S sulfur 32	17 Cl chlorine 35.5	18 Ar argon 40		
11 Na sodium 23	12 Mg magnesium 24	19 K potassium 39	20 Ca calcium 40	21 Sc scandium 45	22 Ti titanium 48	23 V vanadium 51	24 Cr chromium 52	25 Mn manganese 55	26 Fe iron 56	27 Co cobalt 59	28 Ni nickel 59	29 Cu copper 64	30 Zn zinc 65	31 Ga gallium 70	32 Ge germanium 73	33 As arsenic 75	34 Se selenium 79	35 Br bromine 80	36 Kr krypton 84
37 Rb rubidium 85	38 Sr strontium 88	39 Y yttrium 89	40 Zr zirconium 91	41 Nb niobium 93	42 Mo molybdenum 96	43 Tc technetium –	44 Ru ruthenium 101	45 Rh rhodium 103	46 Pd palladium 106	47 Ag silver 108	48 Cd cadmium 112	49 In indium 115	50 Sn tin 119	51 Sb antimony 122	52 Te tellurium 128	53 I iodine 127	54 Xe xenon 131		
55 Cs caesium 133	56 Ba barium 137	57–71 lanthanoids	72 Hf hafnium 178	73 Ta tantalum 181	74 W tungsten 184	75 Re rhenium 186	76 Os osmium 190	77 Ir iridium 192	78 Pt platinum 195	79 Au gold 197	80 Hg mercury 201	81 Tl thallium 204	82 Pb lead 207	83 Bi bismuth 209	84 Po polonium –	85 At astatine –	86 Rn radon –		
87 Fr francium –	88 Ra radium –	89–103 actinoids	104 Rf rutherfordium –	105 Db dubnium –	106 Sg seaborgium –	107 Bh bohrium –	108 Hs hassium –	109 Mt meitnerium –	110 Ds darmstadtium –	111 Rg roentgenium –	112 Cn copernicium –		114 Fl flerovium –		116 Lv livermorium –				

lanthanoids	57 La lanthanum 139	58 Ce cerium 140	59 Pr praseodymium 141	60 Nd neodymium 144	61 Pm promethium –	62 Sm samarium 150	63 Eu europium 152	64 Gd gadolinium 157	65 Tb terbium 159	66 Dy dysprosium 163	67 Ho holmium 165	68 Er erbium 167	69 Tm thulium 169	70 Yb ytterbium 173	71 Lu lutetium 175
actinoids	89 Ac actinium –	90 Th thorium 232	91 Pa protactinium 231	92 U uranium 238	93 Np neptunium –	94 Pu plutonium –	95 Am americium –	96 Cm curium –	97 Bk berkelium –	98 Cf californium –	99 Es einsteinium –	100 Fm fermium –	101 Md mendelevium –	102 No nobelium –	103 Lr lawrencium –

The volume of one mole of any gas is 24 dm<sup>3</sup> at room temperature and pressure (r.t.p.).