

CANDIDATE
NAME

--

CENTRE
NUMBER

--	--	--	--	--

CANDIDATE
NUMBER

--	--	--	--



CO-ORDINATED SCIENCES

Paper 3 Theory (Core)

0654/31

May/June 2018

2 hours

Candidates answer on the Question Paper.

No Additional Materials are required.

READ THESE INSTRUCTIONS FIRST

Write your Centre number, candidate number and name on all the work you hand in.

Write in dark blue or black pen.

You may use an HB pencil for any diagrams or graphs.

Do not use staples, paper clips, glue or correction fluid.

DO NOT WRITE IN ANY BARCODES.

Answer **all** questions.

Electronic calculators may be used.

You may lose marks if you do not show your working or if you do not use appropriate units.

A copy of the Periodic Table is printed on page 27.

At the end of the examination, fasten all your work securely together.

The number of marks is given in brackets [] at the end of each question or part question.

This document consists of **27** printed pages and **1** blank page.

1 Fig. 1.1 shows a diagram of a section through a heart.

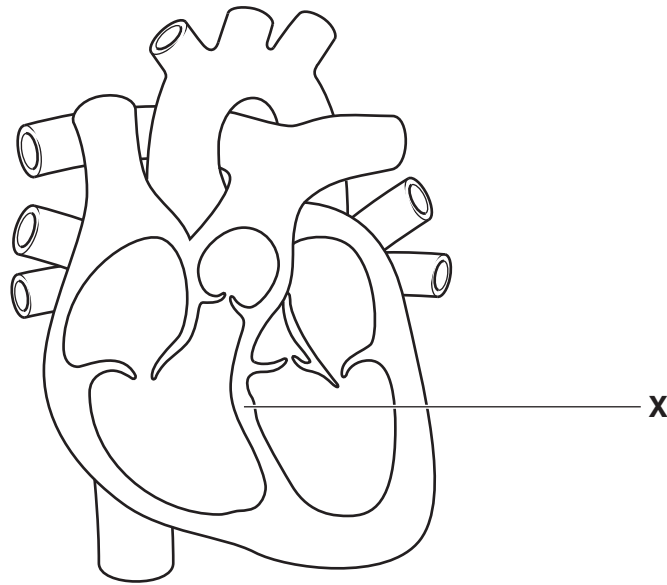

Fig. 1.1

(a) (i) Name the part labelled **X** on Fig. 1.1.

.....[1]

(ii) On Fig. 1.1, draw a label line and the letter **V** to show one of the ventricles of the heart.
[1]

(b) Name the main blood vessel that transports blood from the heart to the lungs.

.....[1]

(c) Describe how the heart moves blood from the heart to the rest of the body.

.....
.....
.....[2]

(d) The boxes on the left show the components of blood.

The boxes on the right show the functions of these components.

Draw **one** line from each component of blood to its correct function.

component of blood	function
red blood cells	phagocytosis and antibody formation
white blood cells	haemoglobin and oxygen transport
platelets	transport of soluble nutrients, ions and hormones
plasma	clotting of blood

[2]

2 Aluminium is a metal and oxygen is a non-metal.

(a) (i) State **two** general **physical** properties of metals.

1

2

[2]

(ii) Complete the sentences using words from the list.

Each word may be used once, more than once or not at all.

- | | | | |
|----------------|------------------|--------------|-----------------|
| atom | electrons | five | molecule |
| protons | six | three | two |

The formula of aluminium oxide, Al_2O_3 , shows
aluminium ions and oxide ions.

There are fewer in an aluminium ion, Al^{3+} , than there
are in an aluminium

[3]

(b) Aluminium is formed at the cathode during the electrolysis of aluminium oxide.

Fig. 2.1 shows this process.

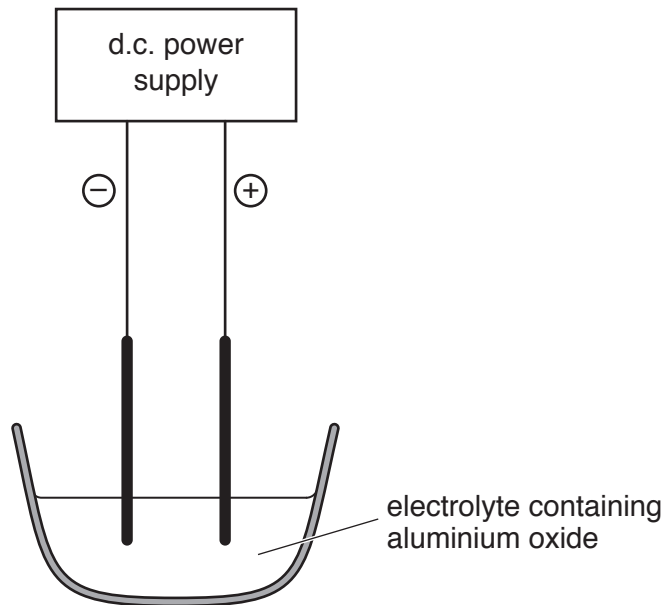

Fig. 2.1

(i) On Fig. 2.1, label the cathode using the letter **C**.

[1]

(ii) Name the element that forms at the anode.

.....[1]

(c) Fig. 2.2 shows a chemical test for the presence of nitrate ions, NO_3^- .

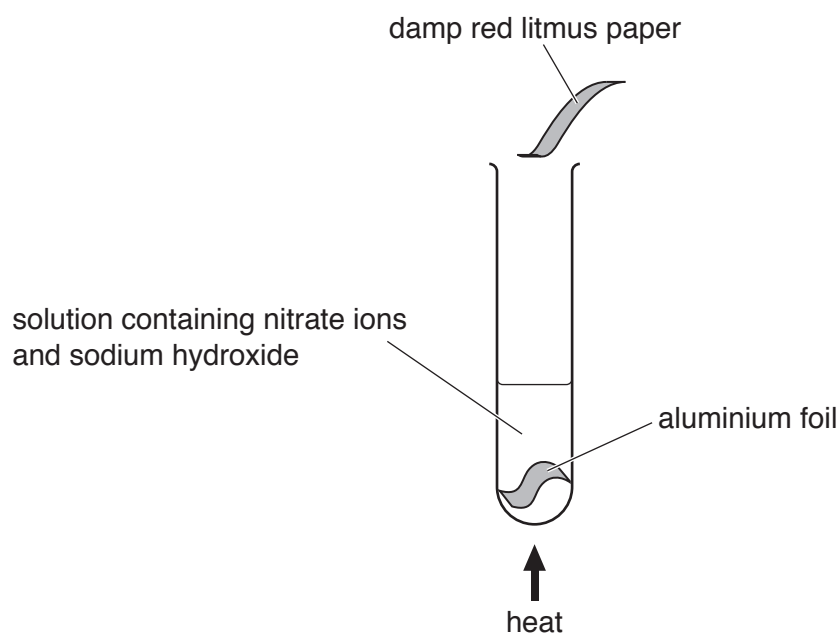

Fig. 2.2

In this test, nitrate ions are reduced and a gaseous compound of nitrogen is released.

(i) State the meaning of the term *reduced*.

.....
[1]

(ii) Name the compound of nitrogen that is released and describe its effect on the damp red litmus paper.

name

effect

[2]

- 3 (a) Fig. 3.1 is a graph showing how the time for the world record for the 100m sprint has decreased since 1930.

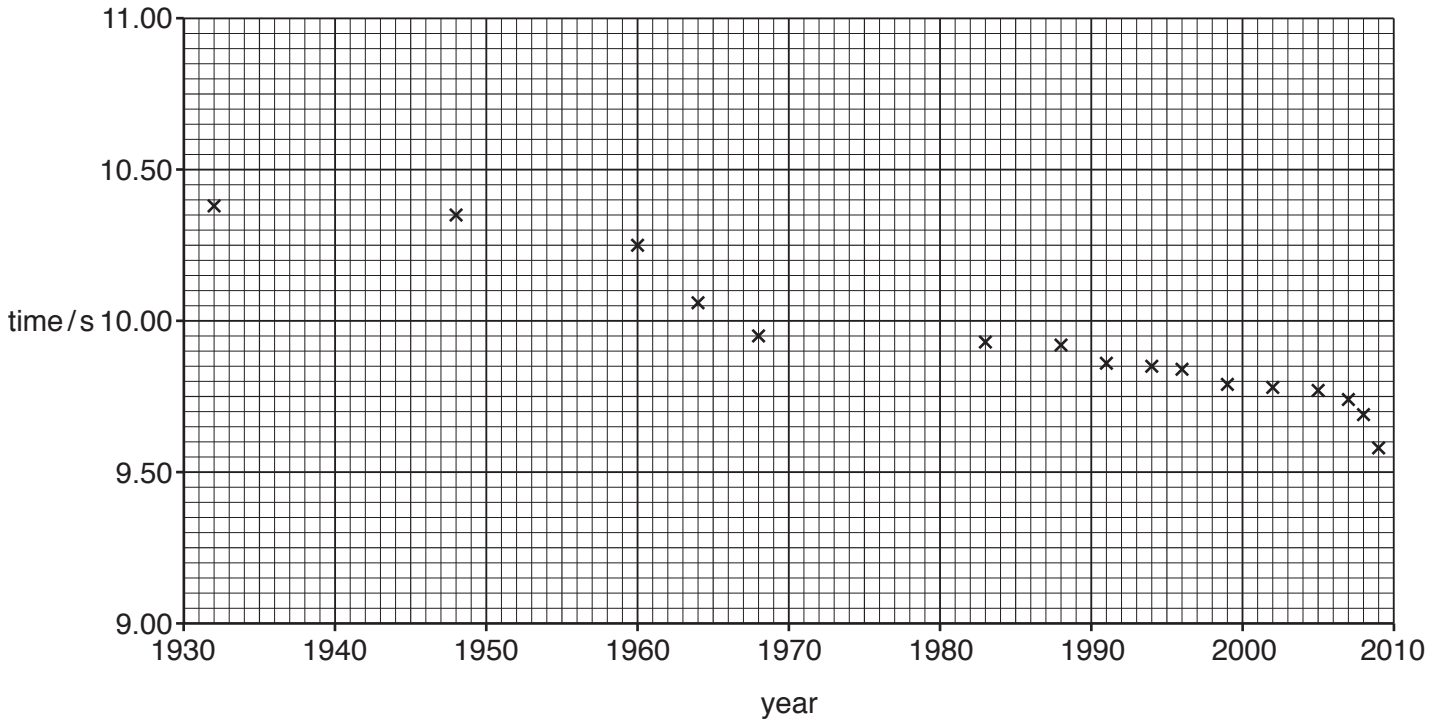

Fig. 3.1

- (i) State the world record time set in 1960.

..... s [1]

- (ii) In 2009, Usain Bolt ran 100 m in 9.58 seconds.

Calculate Usain Bolt's average speed in this race.

State the formula you use and show your working.

formula

working

average speed = m/s [2]

- (iii) Complete the sentence below by choosing the correct forms of energy.

As an athlete runs, the energy in the food he has eaten changes to energy and thermal energy.

[2]

(b) An athlete trains on a running machine.

The running machine measures his power output.

The faster he runs, the greater his power output.

Explain why the athlete's power output is greater when he runs faster.

.....
.....[1]

(c) Fig. 3.2 shows another athlete running in a long distance race.

She pours water over herself.

She is cooled by the evaporation of the water from her body.



Fig. 3.2

Explain, in terms of particles, how the evaporation of water cools the athlete.

.....
.....
.....
.....[2]

4 Fig. 4.1 shows a diagram of a cell in the body.

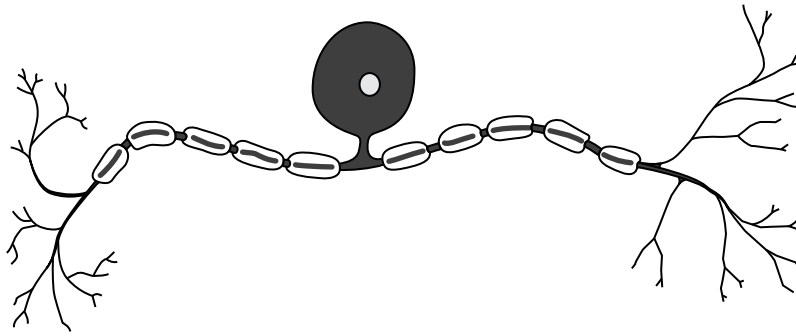

Fig. 4.1

(a) Name the cell in Fig. 4.1.

.....[2]

(b) The cell in Fig. 4.1 is involved in a reflex action.

Describe the pathway of a reflex arc from the initial stimulus to the response.

.....

[3]

(c) Table 4.1 shows examples of different responses by the body.

Place a tick (✓) in the boxes to show **all** the responses that are reflex actions.

Table 4.1

coughing	
running	
sleeping	
sneezing	
sweating	
talking	

[3]

(d) Stimuli causing reflex actions can also result in the release of the hormone adrenaline.

Describe the effects of the release of adrenaline on the body.

.....

.....

..... [2]

- 5 (a) (i) Complete the general equation for the reaction between an acid and an alkali.

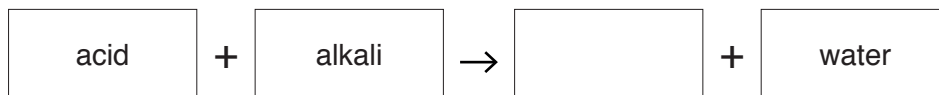

[1]

- (ii) Name the type of chemical reaction in (a)(i).

.....[1]

- (b) Dilute hydrochloric acid reacts with potassium hydroxide solution.

- (i) Complete Table 5.1 by writing the numbers **1**, **7** and **13** to show the pH value of each liquid.

Table 5.1

liquid	pH
dilute hydrochloric acid	
potassium hydroxide solution	
water	

[1]

- (ii) Other than water, name the compound that is produced when hydrochloric acid reacts with potassium hydroxide.

.....[1]

- (iii) Describe how a student could show that the reaction between dilute hydrochloric acid and potassium hydroxide solution is exothermic.

.....

.....[1]

(c) A sample of air is collected near a road in a city.

Six of the gases contained in the sample are listed.

- carbon dioxide
- carbon monoxide
- nitrogen
- nitrogen dioxide
- oxygen
- water vapour

(i) State the gases in the list that are elements.

.....[1]

(ii) Explain why carbon dioxide is a compound and air is a mixture.

carbon dioxide

.....

air

.....

[2]

(iii) State **two** gases in the list that cause air pollution.

1

2

[2]

(iv) State **two** gases in the list that cause the rusting of iron.

1

2

[1]

6 (a) Fig. 6.1 shows the forces acting on a police car when it is travelling at a constant speed.

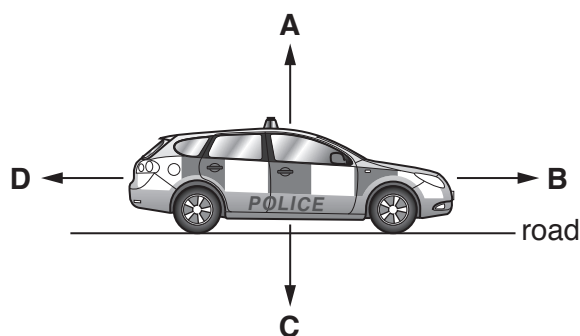

Fig. 6.1

Four forces, **A**, **B**, **C** and **D**, are shown.

(i) State which force, **A**, **B**, **C** or **D**, is the weight of the police car.

..... [1]

(ii) Compare the size and direction of forces **B** and **D** when the car is accelerating in a forwards direction.

.....

 [2]

(iii) Forces can change the motion of an object.

State **one** other effect that a force can have on an object.

..... [1]

(iv) Name the unit of force.

..... [1]

(b) The police car uses a loud siren to alert people.

(i) State how the loudness of the sound of the siren changes when the amplitude of the sound waves emitted increases.

..... [1]

(ii) State how the pitch of the sound of the siren changes when the frequency of the sound waves emitted is reduced.

..... [1]

(c) Cars have rear view mirrors to help the drivers see behind the car.

A driver sees a taxi in his mirror as shown in Fig. 6.2.

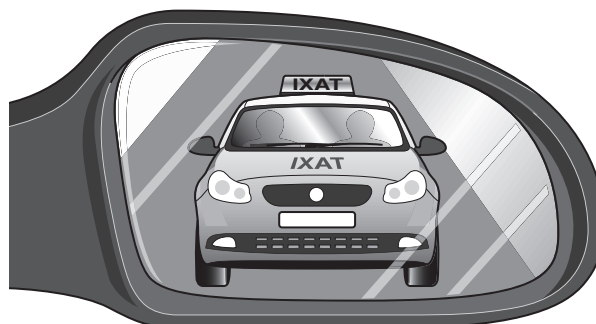

Fig. 6.2

Use Fig. 6.2 to describe **two** characteristics of an image seen in a plane mirror apart from size.

- 1
-
- 2
-

[2]

(d) The bodywork of a car is usually made from steel.

The bodywork of some cars is made from aluminium.

Suggest a simple way of deciding whether the bodywork is made from steel or aluminium.

Explain your answer.

-
- [1]

(e) The car rolls down a hill with the engine switched off.

State the energy transformation that is taking place.

from energy to energy [1]

7 (a) Alleles are different forms of genes.

Complete the sentences about genes using the words from the list.

Each word may be used once, more than once or not at all.

- alleles**
- carbohydrates**
- cell**
- chromosomes**
- DNA**
- nuclei**
- protein**

Genes are found on in the nuclei of cells. A gene is a length of that is the unit of heredity and codes for a specific A gene can be copied and passed on to the next generation. [3]

(b) Diagram **A** in Fig. 7.1 shows a person with an attached earlobe.

Diagram **B** in Fig. 7.1 shows a different person with an unattached earlobe.

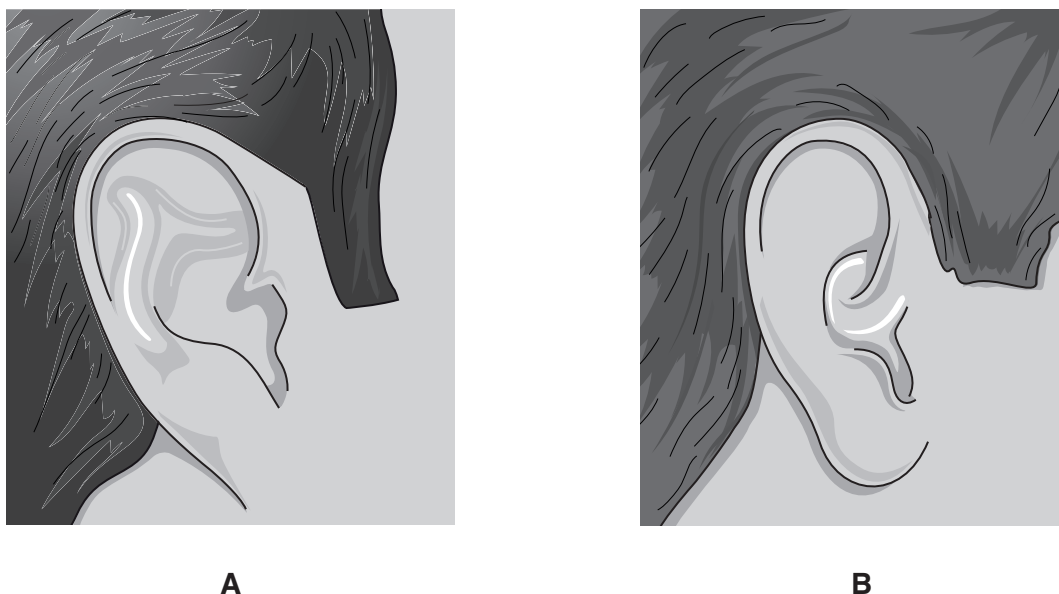

Fig. 7.1

The allele for attached earlobes (**e**) is recessive and the allele for unattached earlobes (**E**) is dominant.

One allele is inherited from the mother and one from the father.

(i) State **all** the possible genotypes for the person in diagram **B** in Fig. 7.1.

.....[2]

(ii) Name the **terms** used to describe the genotype of the person in diagram **A** in Fig. 7.1.

.....[2]

(c) In a population there are more people with unattached earlobes than attached earlobes.

Explain why there are more people with unattached earlobes.

.....

.....

..... [2]

- 8 Fig. 8.1 shows apparatus used by a student to investigate the reaction between excess dilute hydrochloric acid and a piece of limestone.

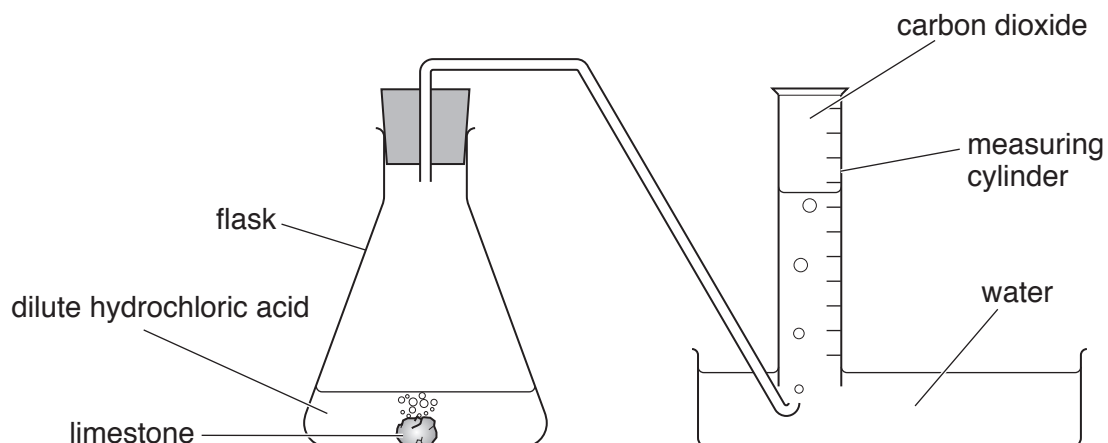

Fig. 8.1

- (a) Name the chemical compound in limestone that reacts with dilute hydrochloric acid to release carbon dioxide.
-[1]
- (b) The student measures the volume of carbon dioxide in the measuring cylinder every minute for seven minutes.

Her results are shown in Fig. 8.2.

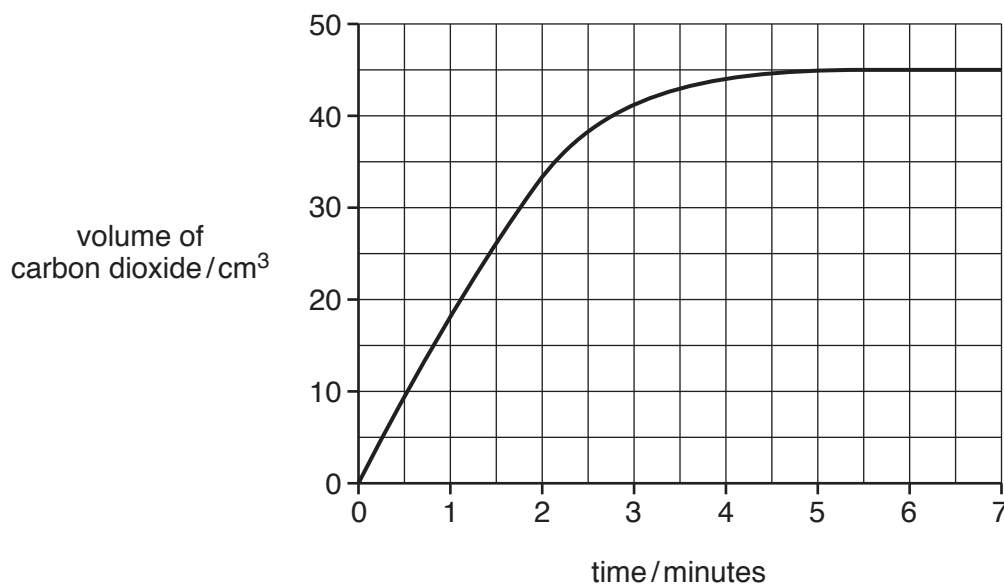

Fig. 8.2

- (i) Use Fig. 8.2 to find the volume of carbon dioxide released.

volume = cm³ [1]

(ii) The student repeats the reaction.

State **one** change she can make so that a greater volume of carbon dioxide is released.

.....[1]

(iii) State **two** changes the student can make to increase the rate of reaction.

1

2

[2]

(c) A white solid and a gas are produced when limestone is heated.

(i) Name the white solid and the gas.

white solid

gas

[2]

(ii) Explain why limestone is spread onto soil that is used for growing crops.

.....

.....

.....[2]

9 (a) Fig. 9.1 shows a heater in a classroom.

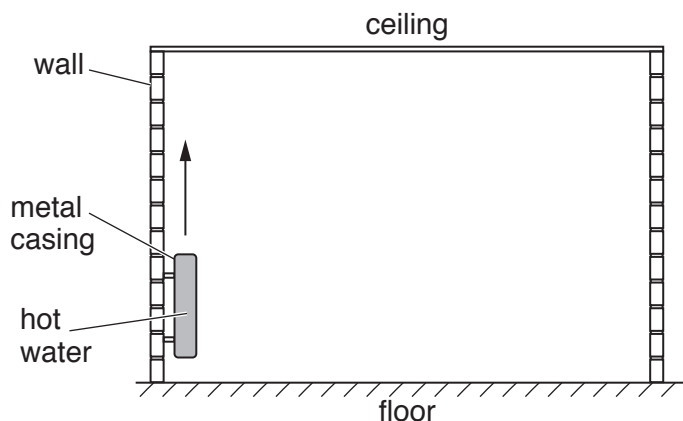

Fig. 9.1

The heater is filled with hot water.

(i) Name the method by which thermal energy passes through the metal casing of the heater.

.....[1]

(ii) The air around the heater is warmed. On Fig. 9.1, draw three arrows to show how the warmed air circulates around the classroom. One arrow has been drawn for you. [2]

(iii) Name the method of thermal energy transfer you have shown in (a)(ii).

.....[1]

(b) In a school, a bell is rung to indicate that a lesson has ended.

The bell produces sound waves that travel through the air.

(i) State why sound waves can travel through the air but cannot travel through outer space.

.....
[1]

(ii) A sound wave is an example of a longitudinal wave.

State **one** example of a transverse wave.

.....[1]

(c) In the school science laboratory, a teacher uses a radioactive isotope of americium.

(i) State the meaning of the term *isotope*.

.....
.....
.....[1]

(ii) Americium-241 decays by emitting α -particles.

Describe the nature of α -particles.

.....
.....[2]

10 Fig. 10.1 shows the activity of some digestive enzymes at different pH values.

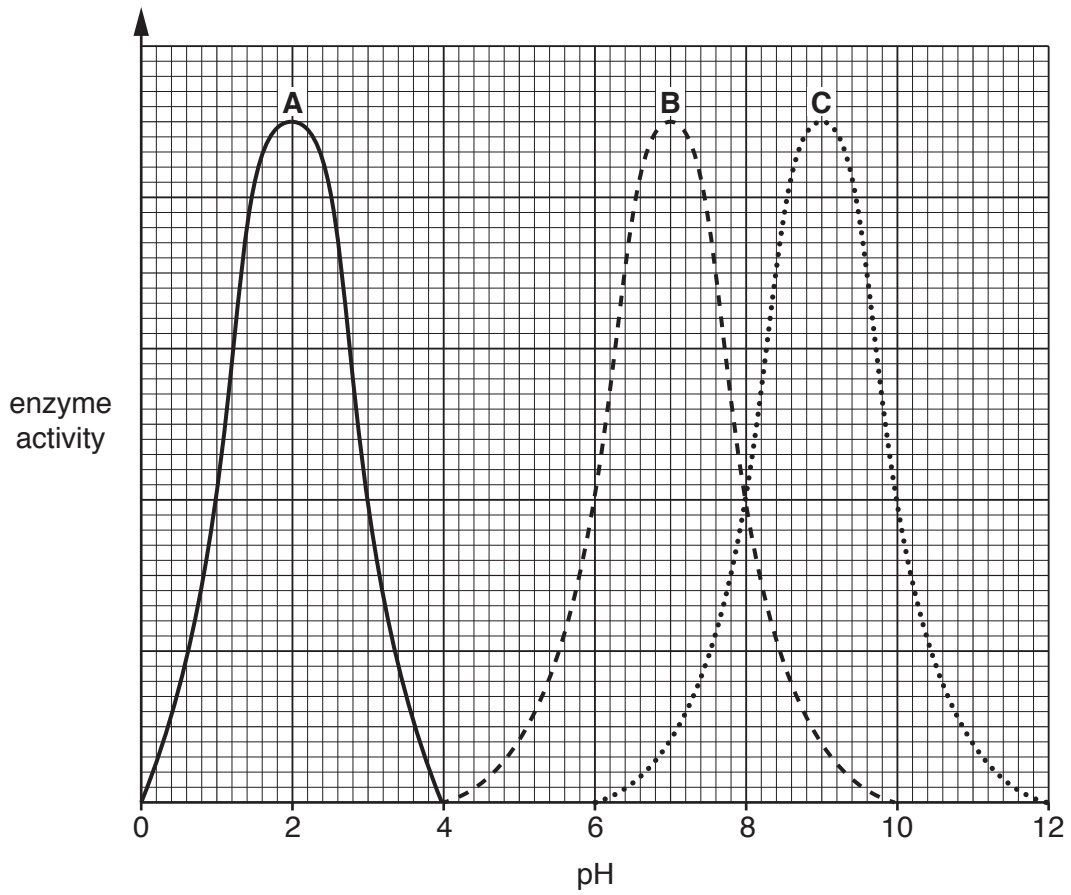

Fig. 10.1

(a) (i) Use Fig. 10.1 to state the optimum pH of enzyme **B**.

..... [1]

(ii) Use Fig. 10.1 to state a pH at which enzyme **C** does **not** work.

..... [1]

(b) Enzyme **A** is the enzyme protease.

(i) State where protease is secreted in the alimentary canal.

..... [1]

(ii) Name the products made by the action of protease.

..... [1]

(c) (i) Describe the function of enzymes in chemical digestion.

.....
.....
.....[2]

(ii) Apart from chemical digestion, state and describe **one** other action in the alimentary canal that aids digestion.

.....
.....
.....[2]

11 The chemical symbols of a chlorine atom and of a bromine atom are shown below.

The symbols include the atomic number and mass number of each atom.

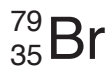

(a) (i) State the number of neutrons in the bromine atom.

..... [1]

(ii) State the number of electrons in the chlorine atom.

..... [1]

(iii) State the number of the group in the Periodic Table that contains chlorine and bromine.

..... [1]

(b) (i) State the colour produced when chlorine reacts with colourless sodium bromide solution.

..... [1]

(ii) Explain your answer to (b)(i) using ideas about reactivity.

.....

 [2]

(c) Hydrocarbon **Y** is mixed with bromine solution.

(i) State the meaning of the term *hydrocarbon*.

.....
 [2]

(ii) No colour change is observed when hydrocarbon **Y** is mixed with bromine solution.

State what this shows about hydrocarbon **Y**.

..... [1]

(d) Describe what happens when ethene molecules react to form poly(ethene).

.....
 [1]

12 (a) The frame of a bicycle can be painted using electrostatic paint spraying.

In electrostatic paint spraying, the surfaces being painted are given a negative electric charge.

The paint droplets leave the spray gun with a positive electric charge.

Fig. 12.1 shows part of the bicycle frame being painted.

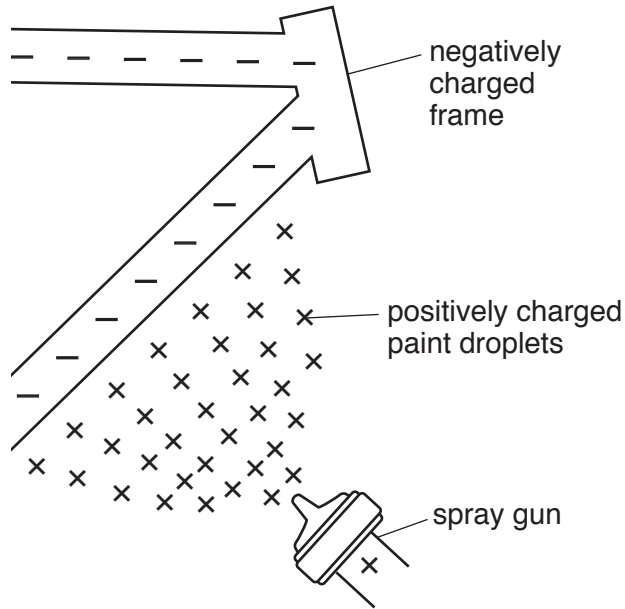

Fig. 12.1

(i) Explain why the positive charges on the paint droplets and the negative charges on the frame make sure that the paint droplets are attracted to the frame.

.....
[1]

(ii) Explain why the positive charges on the paint droplets make sure that the paint droplets spread evenly over the frame.

.....
[1]

(b) The air in a tyre of the bicycle warms up during a journey.

(i) Describe what happens to the molecules in the air inside the tyre as the air warms up.

.....
[1]

(ii) Describe how the molecules in the air in the tyres exert a pressure on the walls of the tyre.

.....
[1]

(c) The bicycle is left outside on a sunny day. Energy from the Sun heats the bicycle.

(i) State the method of energy transfer between the Sun and the Earth.

.....[1]

(ii) Name the part of the electromagnetic spectrum involved in thermal energy transfer from the Sun to the Earth and place it in the correct position in the incomplete electromagnetic spectrum in Fig. 12.2.

γ-rays			visible light			radio waves
--------	--	--	---------------	--	--	-------------

Fig. 12.2

[2]

(d) Fig. 12.3 shows the bicycle with a front lamp **A** and a rear lamp **B** powered by the same cells.

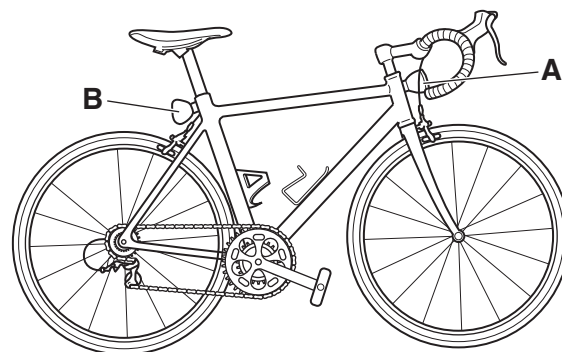

Fig. 12.3

Fig. 12.4 shows the circuit arrangement.

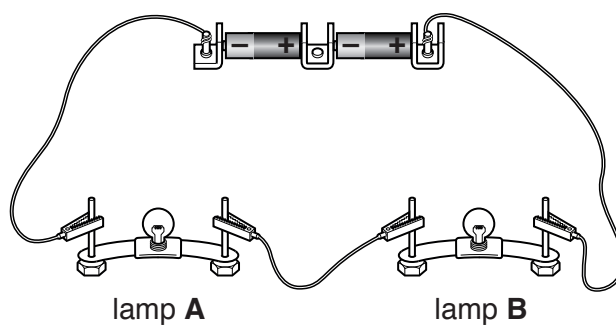

Fig. 12.4

- (i) Using the correct circuit symbols, draw a circuit diagram of this arrangement.

[2]

- (ii) Lamps **A** and **B** are identical. The current in each lamp is 0.4A and the total voltage supplied by the cells is 3.0V.

Calculate the resistance of lamp **A**.

State the formula you use and show your working.

formula

working

resistance = Ω [3]

13 Fig. 13.1 shows a plant responding to a stimulus.

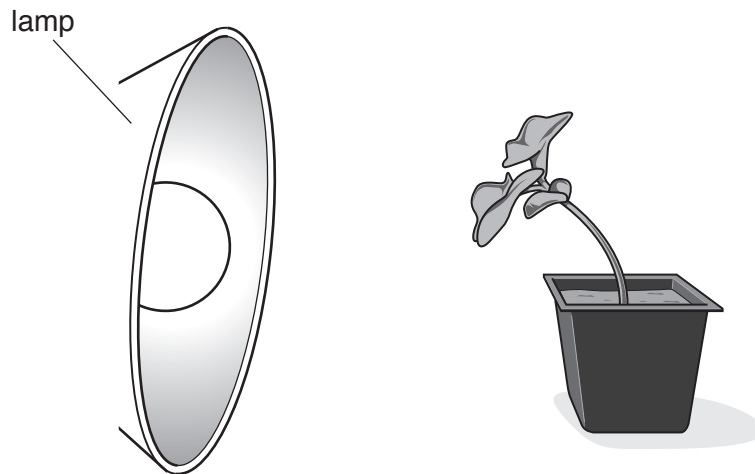

Fig. 13.1

(a) (i) Name the response shown by the plant in Fig. 13.1.

.....[1]

(ii) Describe the advantage to the plant of the response shown in Fig. 13.1.

.....

[2]

(b) The plant in Fig. 13.1 has roots that are used for the uptake of water.

Describe how water is moved from the soil into the plant.

.....

[2]

(c) The roots also take in mineral ions.

State the mineral ion that is required for the production of chlorophyll.

.....[1]

The Periodic Table of Elements

Group																			
I	II											III	IV	V	VI	VII	VIII		
		Key										1 H hydrogen 1							2 He helium 4
		atomic number atomic symbol name relative atomic mass										5 B boron 11	6 C carbon 12	7 N nitrogen 14	8 O oxygen 16	9 F fluorine 19	10 Ne neon 20		
3 Li lithium 7	4 Be beryllium 9											13 Al aluminium 27	14 Si silicon 28	15 P phosphorus 31	16 S sulfur 32	17 Cl chlorine 35.5	18 Ar argon 40		
11 Na sodium 23	12 Mg magnesium 24	19 K potassium 39	20 Ca calcium 40	21 Sc scandium 45	22 Ti titanium 48	23 V vanadium 51	24 Cr chromium 52	25 Mn manganese 55	26 Fe iron 56	27 Co cobalt 59	28 Ni nickel 59	29 Cu copper 64	30 Zn zinc 65	31 Ga gallium 70	32 Ge germanium 73	33 As arsenic 75	34 Se selenium 79	35 Br bromine 80	36 Kr krypton 84
37 Rb rubidium 85	38 Sr strontium 88	39 Y yttrium 89	40 Zr zirconium 91	41 Nb niobium 93	42 Mo molybdenum 96	43 Tc technetium –	44 Ru ruthenium 101	45 Rh rhodium 103	46 Pd palladium 106	47 Ag silver 108	48 Cd cadmium 112	49 In indium 115	50 Sn tin 119	51 Sb antimony 122	52 Te tellurium 128	53 I iodine 127	54 Xe xenon 131		
55 Cs caesium 133	56 Ba barium 137	57–71 lanthanoids	72 Hf hafnium 178	73 Ta tantalum 181	74 W tungsten 184	75 Re rhenium 186	76 Os osmium 190	77 Ir iridium 192	78 Pt platinum 195	79 Au gold 197	80 Hg mercury 201	81 Tl thallium 204	82 Pb lead 207	83 Bi bismuth 209	84 Po polonium –	85 At astatine –	86 Rn radon –		
87 Fr francium –	88 Ra radium –	89–103 actinoids	104 Rf rutherfordium –	105 Db dubnium –	106 Sg seaborgium –	107 Bh bohrium –	108 Hs hassium –	109 Mt meitnerium –	110 Ds darmstadtium –	111 Rg roentgenium –	112 Cn copernicium –	114 Fl flerovium –	116 Lv livermorium –						

lanthanoids	57 La lanthanum 139	58 Ce cerium 140	59 Pr praseodymium 141	60 Nd neodymium 144	61 Pm promethium –	62 Sm samarium 150	63 Eu europium 152	64 Gd gadolinium 157	65 Tb terbium 159	66 Dy dysprosium 163	67 Ho holmium 165	68 Er erbium 167	69 Tm thulium 169	70 Yb ytterbium 173	71 Lu lutetium 175
actinoids	89 Ac actinium –	90 Th thorium 232	91 Pa protactinium 231	92 U uranium 238	93 Np neptunium –	94 Pu plutonium –	95 Am americium –	96 Cm curium –	97 Bk berkelium –	98 Cf californium –	99 Es einsteinium –	100 Fm fermium –	101 Md mendelevium –	102 No nobelium –	103 Lr lawrencium –

The volume of one mole of any gas is 24 dm³ at room temperature and pressure (r.t.p.).

BLANK PAGE

Permission to reproduce items where third-party owned material protected by copyright is included has been sought and cleared where possible. Every reasonable effort has been made by the publisher (UCLES) to trace copyright holders, but if any items requiring clearance have unwittingly been included, the publisher will be pleased to make amends at the earliest possible opportunity.

To avoid the issue of disclosure of answer-related information to candidates, all copyright acknowledgements are reproduced online in the Cambridge International Examinations Copyright Acknowledgements Booklet. This is produced for each series of examinations and is freely available to download at www.cie.org.uk after the live examination series.

Cambridge International Examinations is part of the Cambridge Assessment Group. Cambridge Assessment is the brand name of University of Cambridge Local Examinations Syndicate (UCLES), which is itself a department of the University of Cambridge.