



**Cambridge International Examinations**  
Cambridge International General Certificate of Secondary Education

CANDIDATE NAME

CENTRE NUMBER

CANDIDATE NUMBER



**CO-ORDINATED SCIENCES**

**0654/41**

Paper 4 Theory (Extended)

**May/June 2018**

**2 hours**

Candidates answer on the Question Paper.

No Additional Materials are required.

**READ THESE INSTRUCTIONS FIRST**

Write your Centre number, candidate number and name on all the work you hand in.

Write in dark blue or black pen.

You may use an HB pencil for any diagrams or graphs.

Do not use staples, paper clips, glue or correction fluid.

**DO NOT WRITE IN ANY BARCODES.**

Answer **all** questions.

Electronic calculators may be used.

You may lose marks if you do not show your working or if you do not use appropriate units.

A copy of the Periodic Table is printed on page 32.

At the end of the examination, fasten all your work securely together.

The number of marks is given in brackets [ ] at the end of each question or part question.

This document consists of **30** printed pages and **2** blank pages.

- 1 (a) The lining of the small intestine is covered with villi.

Fig. 1.1 shows a cross-section of a villus.

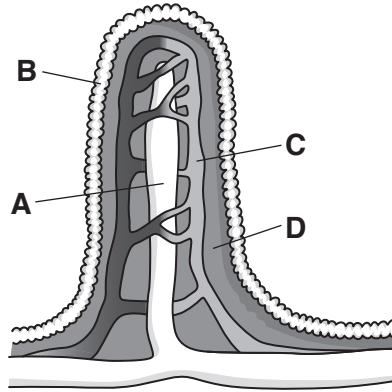

Fig. 1.1

- (i) Using the letters **A**, **B**, **C** and **D** in Fig. 1.1, identify the part where fat is absorbed, .....  
glucose enters the blood stream. ....

[2]

- (ii) Explain how the shape of the villus is related to its function.

.....  
.....  
.....[2]

- (b) Fats are an important part of the diet.

State the smaller basic units that make up fats.

.....[1]

- (c) Describe how bile aids the breakdown of fats.

.....  
.....  
.....[2]

(d) A person eats too much fat in their diet. One of the consequences of this is obesity.

Suggest a disease that can be caused by too much fat in the diet.

.....[1]

(e) One way to reduce the risk of obesity is to reduce the amount of fat eaten.

Suggest **one** other way to reduce the risk of obesity.

.....  
.....[1]

2 Fig. 2.1 shows the industrial electrolysis used to extract aluminium from aluminium oxide.

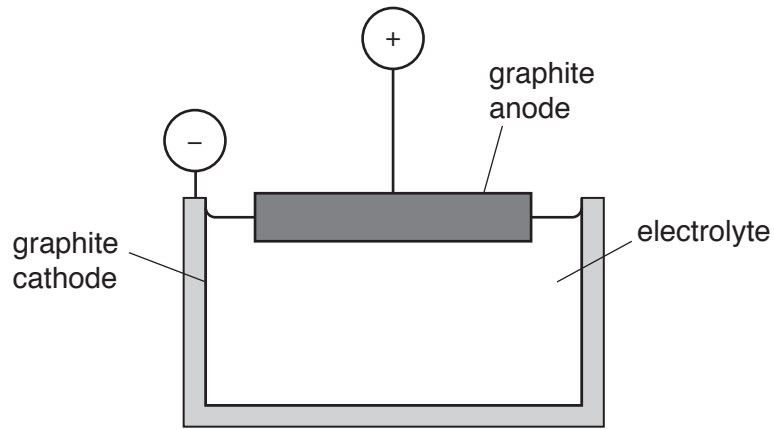

Fig. 2.1

(a) (i) Aluminium oxide contains aluminium ions,  $Al^{3+}$ , and oxide ions,  $O^{2-}$ .

Deduce the formula of aluminium oxide.

..... [1]

(ii) Explain why the ionic compound aluminium oxide has a high melting point.

.....  
 .....  
 ..... [2]

(iii) Compound **X** and aluminium oxide are mixed together to form the electrolyte.

Name compound **X** and explain why it is mixed with aluminium oxide.

compound **X** .....

explanation .....

.....  
 ..... [2]

(iv) Fig. 2.2 shows the position of an aluminium ion in the electrolyte.

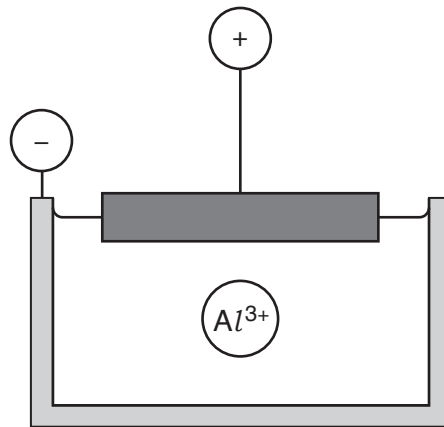

**Fig. 2.2**

Describe what happens to this ion during electrolysis.

.....

.....

.....

.....

.....

.....

.....[3]

(b) The anode in the process in Fig. 2.1 oxidises to form carbon dioxide.

Complete Fig. 2.3 to show the dot-and-cross diagram of the covalent bonding in carbon dioxide.

Show all of the outer-shell electrons in all of the atoms.

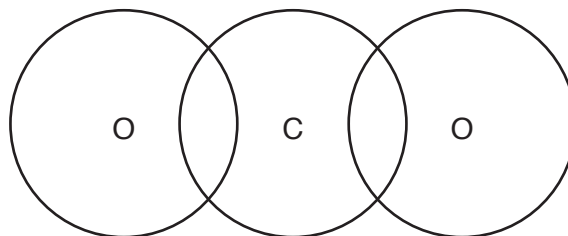

**Fig. 2.3**

[2]

- 3 (a) Fig. 3.1 shows a farmer driving a tractor.

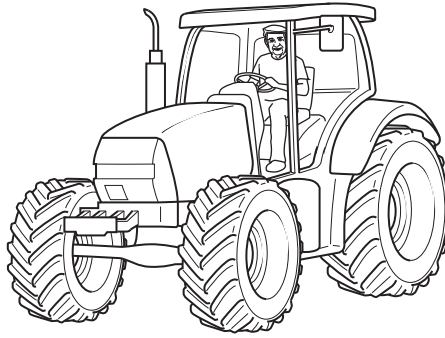

**Fig. 3.1**

- (i) The tractor accelerates across horizontal ground from 4 m/s to 6 m/s in 12 s.

The mass of the tractor is 4800 kg.

Calculate the force required to produce this acceleration.

State the formulae you use and show all your working.

formula

working

formula

working

force = ..... N [4]

- (ii) Calculate the **increase** in kinetic energy of the tractor when accelerating from 4 m/s to 6 m/s.

State the formula you use and show your working.

formula

working

increase in kinetic energy = ..... J [3]

- (b) While the farmer is on his tractor, he uses a solar-powered charging device to charge the battery in his mobile (cell) phone.

Fig. 3.2 shows the phone and charger.

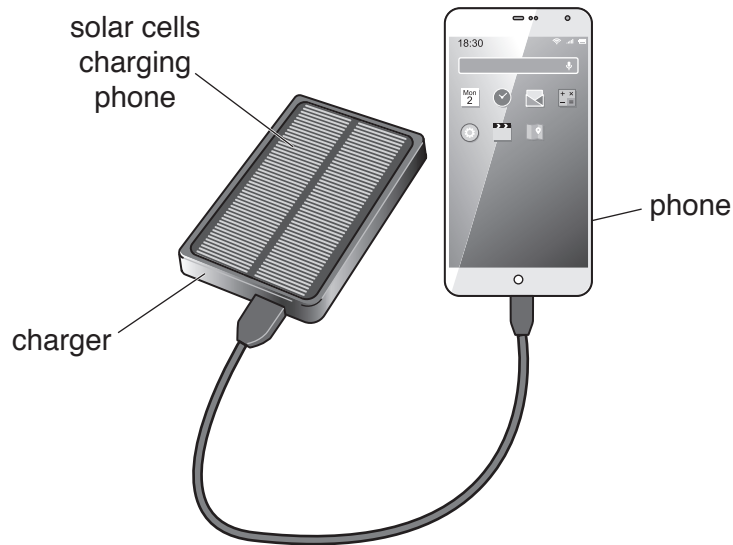

**Fig. 3.2**

The solar cells are 25% efficient.

These produce an output of 0.5 J of electrical energy per second to the phone.

Calculate the solar energy input per second to the charger.

State the formula you use and show your working.

formula

working

energy input = ..... J [2]

- (c) The farmer uses a lens to focus the Sun's rays onto dry grass to light a small fire.

Fig. 3.3 shows the arrangement.

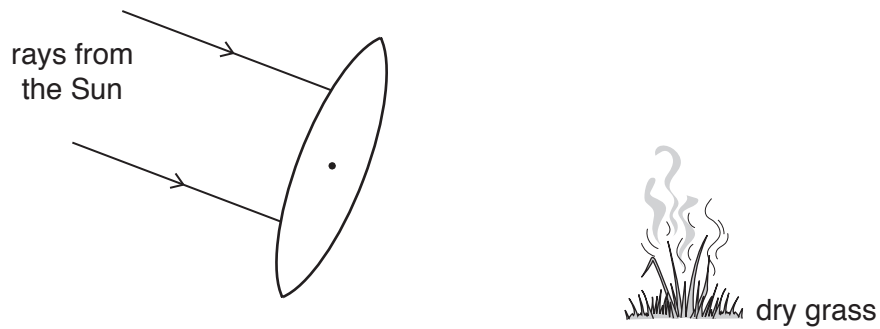

**Fig. 3.3**

- (i) Draw the rays of light after they leave the lens. [2]
- (ii) The lens produces a real image of the Sun.

Describe the difference between a *real* image and a *virtual* image.

.....

.....

.....[1]



**Please turn over for Question 4.**

4 Fig. 4.1 shows the number of cigarettes smoked per person per year in the USA.

Fig. 4.1 also shows the number of deaths per 100 000 people per year caused by lung cancer in the USA.

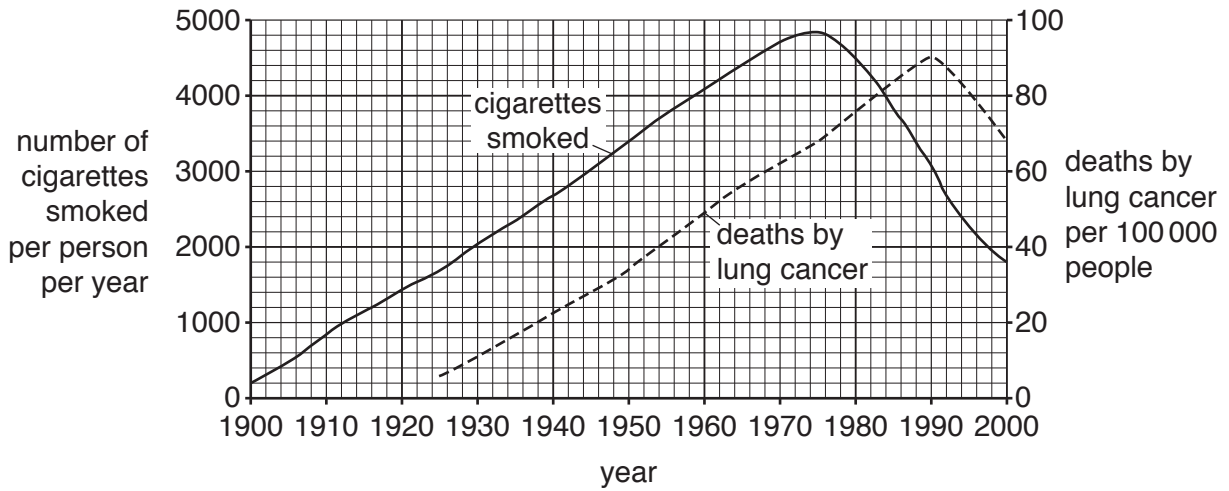

Fig. 4.1

(a) (i) Describe the trend in deaths by lung cancer shown in Fig. 4.1.

.....

.....

.....

..... [2]

(ii) Suggest **two** reasons why the number of cigarettes smoked per person decreased after 1975.

1 .....

2 ..... [2]

(b) Suggest why there is a lag between number of cigarettes smoked and lung cancer deaths.

.....

..... [1]

(c) The boxes on the left show components of tobacco smoke.

The boxes on the right show their effects on the body.

Draw **four** lines to link the components of tobacco smoke to their main effect on the body.

**component of tobacco smoke**

**effect on the body**

carbon monoxide

addiction

nicotine

reduces oxygen-carrying capacity of the blood

smoke particles

causes cancer

tar

irritant

[3]

(d) Explain why smokers are more likely than non-smokers to develop bacterial lung infections.

Use the words **cilia** and **mucus** in your answer.

.....

.....

.....

.....

.....

.....

.....[3]

- 5 (a) Complete the general equation for the reaction between an acid and an alkali.

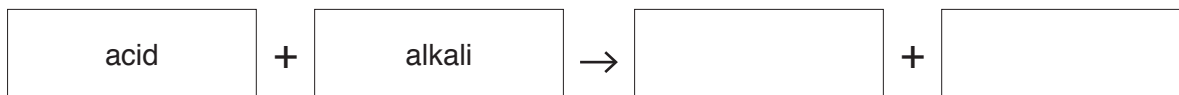

[1]

- (b) Table 5.1 shows the aqueous ions contained in dilute hydrochloric acid and in potassium hydroxide solution.

**Table 5.1**

aqueous solution	positive ion	negative ion
dilute hydrochloric acid	$H^+$	$Cl^-$
potassium hydroxide	$K^+$	$OH^-$

- (i) Construct the **balanced symbolic** equation for the reaction between dilute hydrochloric acid and potassium hydroxide solution.

Include state symbols.

.....[2]

- (ii) Identify the **two** ions that combine to form a covalent compound in this reaction.

..... and .....[1]

- (c) Dilute sulfuric acid reacts with magnesium to release hydrogen.

The equation for this reaction is shown.

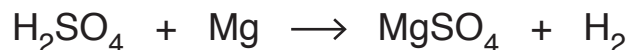

- (i) Complete the steps in the calculation below to find the volume of hydrogen gas that is produced when 0.072 g of magnesium reacts in excess dilute sulfuric acid.

**Step 1**

Calculate the number of moles of magnesium in 0.072 g.

number of moles = .....

**Step 2**

State the number of moles of hydrogen gas produced when 0.072 g of magnesium reacts.

number of moles = .....

**Step 3**

Calculate the volume of hydrogen, in  $\text{dm}^3$ , produced when 0.072 g of magnesium reacts.

[Molar gas volume =  $24.0 \text{ dm}^3$ ]

volume = .....  $\text{dm}^3$   
[3]

- (ii) State the name given to the number of atoms contained in one mole of magnesium.

.....[1]

6 A wind turbine generates alternating current (a.c.) electricity.

(a) Table 6.1 lists some electrical components.

Put ticks (✓) in the table next to the **two** components that an electrical generator must contain.

**Table 6.1**

ammeter	
battery	
light bulb	
magnet	
voltmeter	
wire coil	

[2]

(b) When electricity has been generated, a step-up transformer increases the voltage before the electricity is transmitted through cables to a nearby town.

(i) Explain why the voltage of the electricity is increased before transmission.

.....  
 .....  
 ..... [2]

(ii) The output from the wind turbine is 700 V. The voltage is stepped up by a transformer.

The number of turns on the primary coil of the transformer is 28 000.

The number of turns on the secondary coil of the transformer is 440 000.

Calculate the output voltage from the transformer.

State the formula you use and show your working.

formula

working

output voltage = ..... V [2]

- (c) Wind turbines are noisy when they are turning. When they turn faster, the sound waves emitted have a larger amplitude.

State how the loudness of the sound of the wind turbine changes when the amplitude of the sound waves emitted increases.

.....[1]

- (d) Sound waves pass through the air as a series of compressions and rarefactions.

- (i) State what is meant by a *compression*.

.....  
.....[1]

- (ii) Describe the wavelength of a sound wave in terms of compressions.

.....  
.....[1]

- 7 Fig. 7.1 shows apparatus used by a student to investigate the rate of reaction between excess dilute hydrochloric acid and a piece of limestone.

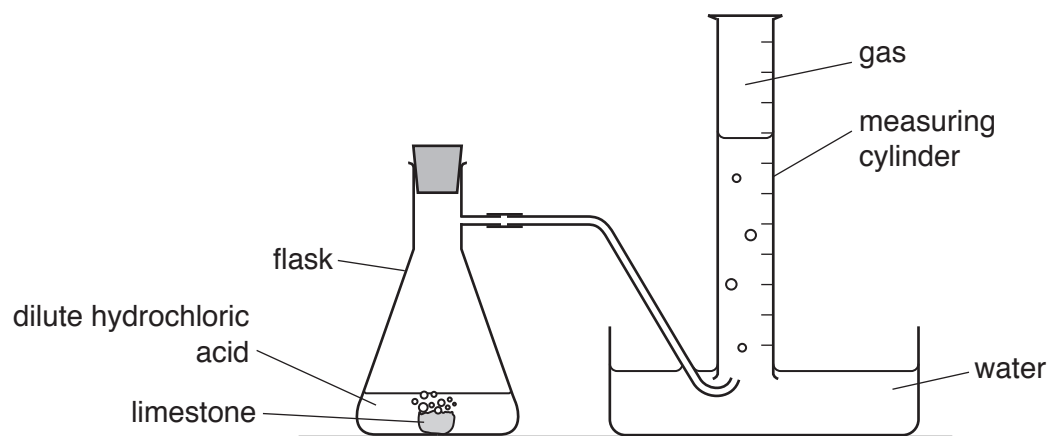

Fig. 7.1

The student measures the volume of gas in the measuring cylinder every minute for nine minutes.

Her results are shown in Fig. 7.2.

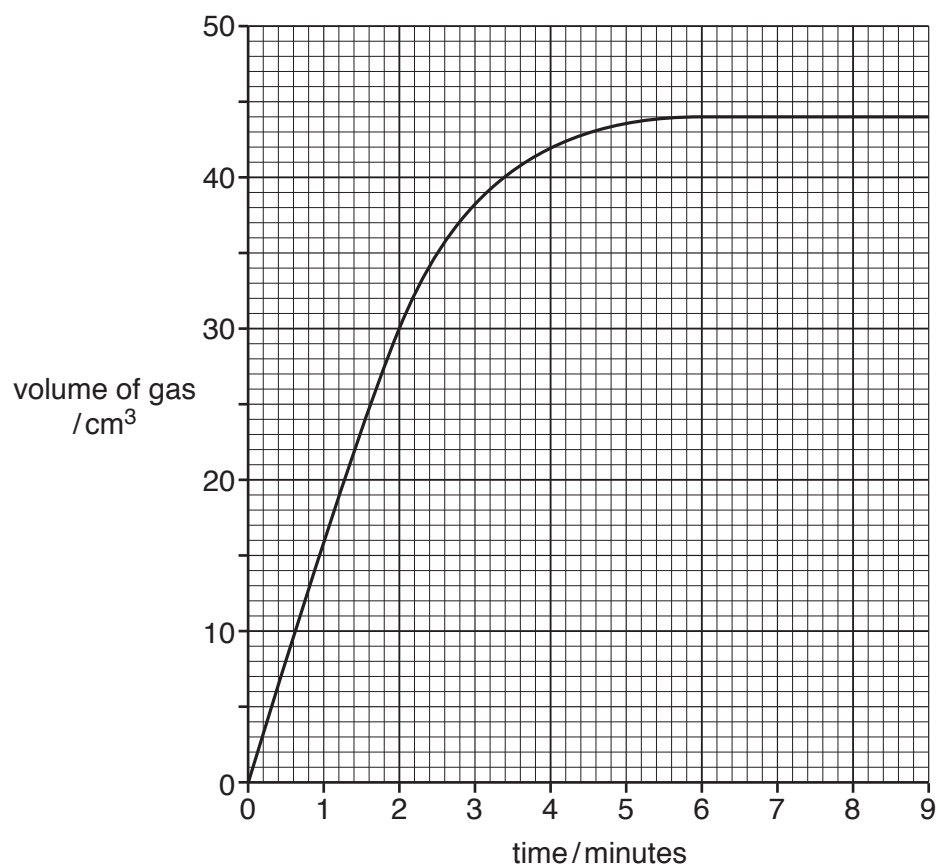

Fig. 7.2



(a) (i) Name the main chemical compound in limestone.

.....[1]

(ii) Name the gas that collects in the measuring cylinder.

.....[1]

(b) The student uses **excess** dilute hydrochloric acid.

(i) Use Fig. 7.2 to deduce the time taken for half of the limestone to react.

Explain your answer.

time taken = ..... minutes

explanation .....

.....[2]

(ii) The graph shows that the rate of reaction changes.

Explain, in terms of particles, why the rate of reaction decreases.

.....

.....

.....[2]

(c) Lime is produced from limestone in a lime kiln.

Fig. 7.3 shows a lime kiln.

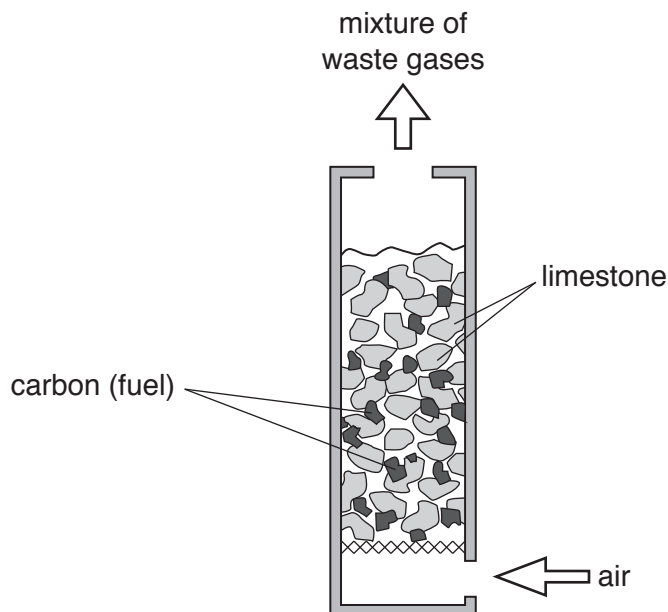

Fig. 7.3

(i) Identify the exothermic reaction and the endothermic reaction occurring in the lime kiln.

exothermic reaction .....

.....

endothermic reaction .....

.....

[2]

(ii) State the energy change that occurs in an **endothermic** reaction.

from ..... energy to ..... energy

[2]

(iii) Explain why the mixture of waste gases contains a large amount of nitrogen.

Use ideas about reactivity in your answer.

.....

.....

.....

[2]

8 A farmer has a group of rabbits. The coat colours of the rabbits are recorded.

Table 8.1 shows the results.

**Table 8.1**

coat colour	number of rabbits
black	13
white	15
grey	33
brown	14

(a) (i) Calculate the percentage of rabbits with white coat colour.

Show your working.

percentage = ..... % [2]

(ii) State the type of variation shown by the rabbits in Table 8.1.

..... [1]

(iii) Suggest the cause of the type of variation stated in your answer to (a)(ii).

..... [1]

(b) The farmer breeds some of the rabbits.

One of the rabbits is born with an orange coat colour.

Suggest a cause for this unusual colour.

..... [1]

(c) The rabbits with brown coat colour are the most popular and are sold for more money.

Describe what steps the farmer could take to increase the number of rabbits born with brown coat colour.

.....  
 .....  
 .....  
 .....  
 ..... [3]

9 (a) Fig. 9.1 shows a washing machine connected to a 230 V supply.

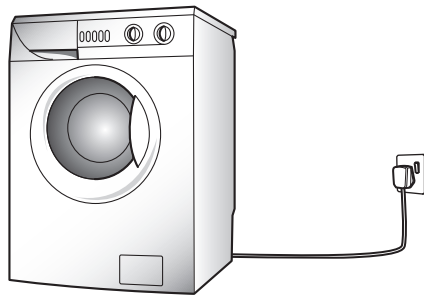

Fig. 9.1

(i) The washing machine uses 2500 W of power when operating.

Name the unit with the symbol W.

.....[1]

(ii) Calculate the current when the washing machine is operating.

State the formula you use and show your working.

formula

working

current = ..... A [2]

(b) Inside the washing machine, the water is heated by an electric heater.

Describe, in terms of particles, how thermal energy is able to pass through the metal parts of the heater.

.....  
.....  
.....  
.....[2]

(c) The washing machine is filled with 15.0 kg of water at an initial temperature of 20 °C.

The energy required to heat the water to 60 °C is 2520 kJ.

Calculate the specific heat capacity of water.

State the formula you use, show your working and state the units of your answer.

formula

working

specific heat capacity = ..... units ..... [3]

(d) Some wet clothes are hung outside on a line to dry. The water still in the clothes is able to evaporate. The water evaporates more quickly on a warm day than on a cool day.

Describe **and** explain why warm conditions increase the rate of evaporation.

.....  
.....  
.....  
.....  
..... [2]

10 (a) A freshwater lake is an example of an ecosystem.

Use the words to complete the definition of the term *ecosystem*.

Each word may be used once, more than once or not at all.

- animals
- environment
- food
- homes
- organisms
- plants
- prey

An ecosystem is a unit containing all of the ..... and their ....., interacting together, in a given area. [2]

(b) Fig. 10.1 shows part of a food web from a freshwater lake ecosystem.

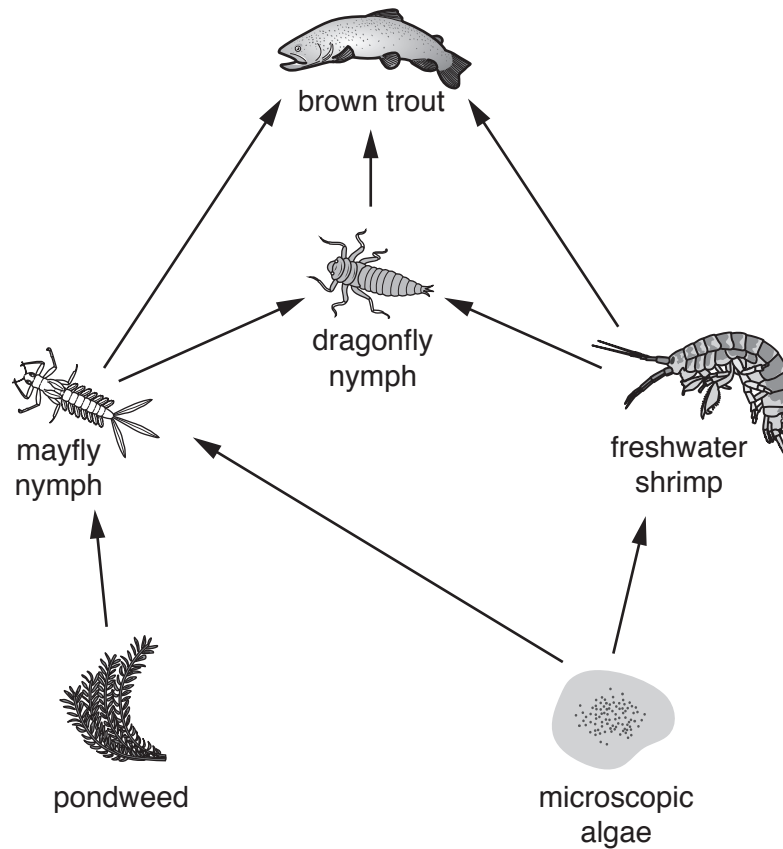

Fig. 10.1

Explain why brown trout can be described as feeding at the 3rd or 4th trophic level.

.....

.....

.....[2]

(c) This food web has four trophic levels.

Explain why most food webs do **not** have more than five trophic levels.

.....

.....

..... [2]

11 The chemical symbols of a chlorine atom and of a bromine atom are shown below.

The symbols include the atomic number and mass number of each atom.

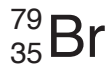
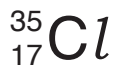

(a) (i) State the number of neutrons in the bromine atom.

..... [1]

(ii) State the electronic structure of a chlorine atom.

..... [2]

(b) Describe the colour change when ethene is bubbled through bromine solution.

from ..... to ..... [1]

(c) Polymers are formed when monomers join together in polymerisation reactions.

(i) Ethene reacts to form poly(ethene).

Complete Fig. 11.1 to show part of a poly(ethene) molecule.

Your sketch should show four carbon atoms.

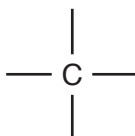

Fig. 11.1

[3]

(ii) State the type of polymerisation reaction that forms poly(ethene) from ethene.

..... [1]



(iii) Proteins are polymers formed from amino acids.

Describe **one** way in which protein molecules may be broken down to release the amino acids.

.....

.....

..... [2]

- 12 (a) Fig. 12.1 shows two bicycles that are left outside on a sunny day.

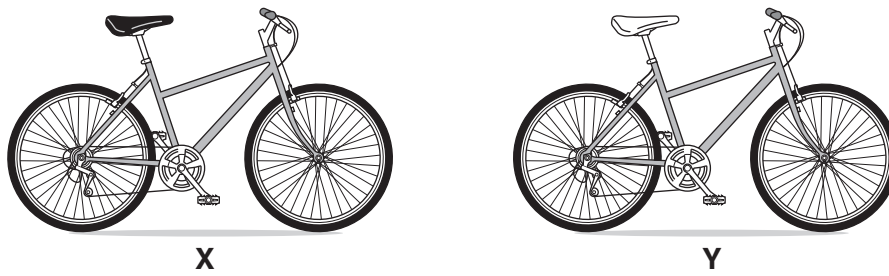

Fig. 12.1

The bicycles are identical apart from the saddles.

Bicycle **X** has a black saddle and bicycle **Y** has a white saddle.

The saddle on bicycle **X** gets much hotter than the saddle on bicycle **Y**.

Explain why this happens.

.....

.....[1]

- (b) Fig. 12.2 shows a bicycle with a rear lamp **A** and a front lamp **B** powered by the same 9.0 V battery.

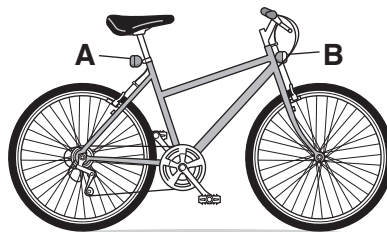

Fig. 12.2

Fig. 12.3 is a circuit diagram to show how the lamps are connected.

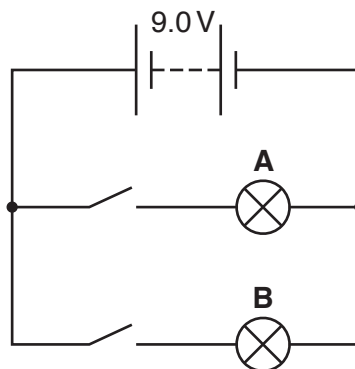

Fig. 12.3

- (i) Lamp **A** has a resistance of  $8\ \Omega$  and lamp **B** has a resistance of  $16\ \Omega$ .

Calculate the combined resistance of the two lamps in this circuit.

Show your working.

resistance = .....  $\Omega$  [2]

- (ii) Calculate the current passing through lamp **A**.

State the formula you use and show your working.

formula

working

current = ..... A [2]

- (c) The bicycle lamps emit energy as visible light and infra-red radiation.

These are both parts of the electromagnetic spectrum.

- (i) Place visible light and infra-red in their correct positions in the incomplete electromagnetic spectrum in Fig. 12.4.

$\gamma$ -rays		ultraviolet			microwaves	
----------------	--	-------------	--	--	------------	--

Fig. 12.4

[1]

- (ii) The speed of infra-red radiation in air is 300 000 000 m/s.

The wavelength of the infra-red radiation emitted is 750 nm.

(1 nm =  $10^{-9}$  m)

Calculate the frequency of the infra-red radiation.

State the formula you use and show your working.

formula

working

frequency = ..... Hz [2]

- (iii)  $\gamma$ -radiation may be released from the nuclei of atoms when they decay.

$\alpha$ -particles and  $\beta$ -particles may also be emitted.

State which radioactive emission,  $\alpha$ ,  $\beta$  or  $\gamma$ , is the most ionising.

.....[1]

13 Fig. 13.1 shows a diagram of the alimentary canal and associated organs.

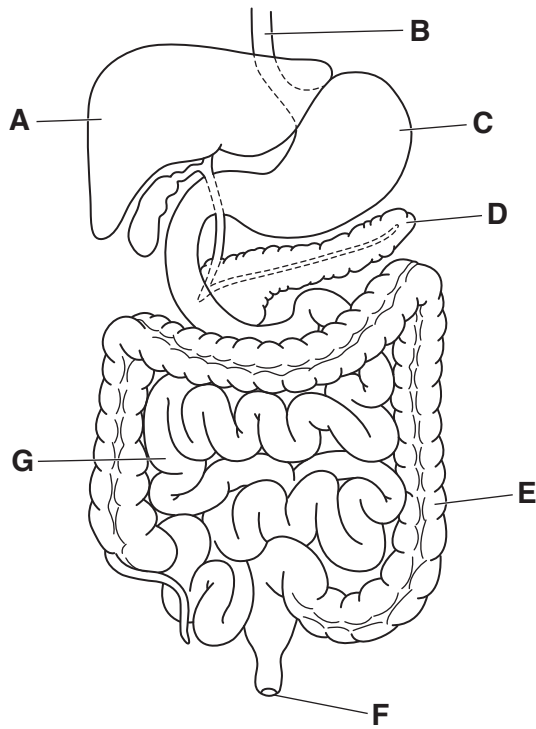

Fig. 13.1

- (a) State the letter in Fig. 13.1 that identifies the  
 liver, .....
- pancreas. ....

[2]

- (b) When a person eats a meal, the concentration of glucose in their blood increases. The pancreas detects this increase.

Describe how the pancreas **and** the liver bring the concentration of glucose back to normal.

.....

.....

.....[2]

- (c) State a term that can be used to describe the control of the concentration of glucose in the blood.

.....[1]

- (d) Glucose is a carbohydrate.

State the chemical elements contained in glucose.

.....[1]



**BLANK PAGE**

---

Permission to reproduce items where third-party owned material protected by copyright is included has been sought and cleared where possible. Every reasonable effort has been made by the publisher (UCLES) to trace copyright holders, but if any items requiring clearance have unwittingly been included, the publisher will be pleased to make amends at the earliest possible opportunity.

To avoid the issue of disclosure of answer-related information to candidates, all copyright acknowledgements are reproduced online in the Cambridge International Examinations Copyright Acknowledgements Booklet. This is produced for each series of examinations and is freely available to download at [www.cie.org.uk](http://www.cie.org.uk) after the live examination series.

Cambridge International Examinations is part of the Cambridge Assessment Group. Cambridge Assessment is the brand name of University of Cambridge Local Examinations Syndicate (UCLES), which is itself a department of the University of Cambridge.

## The Periodic Table of Elements

Group																											
I	II											III	IV	V	VI	VII	VIII										
<div style="border: 1px solid black; padding: 5px; width: fit-content; margin: auto;"> <p style="text-align: center;"><b>Key</b></p> <p style="text-align: center;">atomic number atomic symbol name relative atomic mass</p> </div>											1 <b>H</b> hydrogen 1																2 <b>He</b> helium 4
											3 <b>Li</b> lithium 7		4 <b>Be</b> beryllium 9												5 <b>B</b> boron 11	6 <b>C</b> carbon 12	7 <b>N</b> nitrogen 14
11 <b>Na</b> sodium 23		12 <b>Mg</b> magnesium 24												13 <b>Al</b> aluminium 27	14 <b>Si</b> silicon 28	15 <b>P</b> phosphorus 31	16 <b>S</b> sulfur 32	17 <b>Cl</b> chlorine 35.5	18 <b>Ar</b> argon 40								
19 <b>K</b> potassium 39	20 <b>Ca</b> calcium 40	21 <b>Sc</b> scandium 45	22 <b>Ti</b> titanium 48	23 <b>V</b> vanadium 51	24 <b>Cr</b> chromium 52	25 <b>Mn</b> manganese 55	26 <b>Fe</b> iron 56	27 <b>Co</b> cobalt 59	28 <b>Ni</b> nickel 59	29 <b>Cu</b> copper 64	30 <b>Zn</b> zinc 65	31 <b>Ga</b> gallium 70	32 <b>Ge</b> germanium 73	33 <b>As</b> arsenic 75	34 <b>Se</b> selenium 79	35 <b>Br</b> bromine 80	36 <b>Kr</b> krypton 84										
37 <b>Rb</b> rubidium 85	38 <b>Sr</b> strontium 88	39 <b>Y</b> yttrium 89	40 <b>Zr</b> zirconium 91	41 <b>Nb</b> niobium 93	42 <b>Mo</b> molybdenum 96	43 <b>Tc</b> technetium –	44 <b>Ru</b> ruthenium 101	45 <b>Rh</b> rhodium 103	46 <b>Pd</b> palladium 106	47 <b>Ag</b> silver 108	48 <b>Cd</b> cadmium 112	49 <b>In</b> indium 115	50 <b>Sn</b> tin 119	51 <b>Sb</b> antimony 122	52 <b>Te</b> tellurium 128	53 <b>I</b> iodine 127	54 <b>Xe</b> xenon 131										
55 <b>Cs</b> caesium 133	56 <b>Ba</b> barium 137	57–71 lanthanoids	72 <b>Hf</b> hafnium 178	73 <b>Ta</b> tantalum 181	74 <b>W</b> tungsten 184	75 <b>Re</b> rhenium 186	76 <b>Os</b> osmium 190	77 <b>Ir</b> iridium 192	78 <b>Pt</b> platinum 195	79 <b>Au</b> gold 197	80 <b>Hg</b> mercury 201	81 <b>Tl</b> thallium 204	82 <b>Pb</b> lead 207	83 <b>Bi</b> bismuth 209	84 <b>Po</b> polonium –	85 <b>At</b> astatine –	86 <b>Rn</b> radon –										
87 <b>Fr</b> francium –	88 <b>Ra</b> radium –	89–103 actinoids	104 <b>Rf</b> rutherfordium –	105 <b>Db</b> dubnium –	106 <b>Sg</b> seaborgium –	107 <b>Bh</b> bohrium –	108 <b>Hs</b> hassium –	109 <b>Mt</b> meitnerium –	110 <b>Ds</b> darmstadtium –	111 <b>Rg</b> roentgenium –	112 <b>Cn</b> copernicium –	114 <b>Fl</b> flerovium –	116 <b>Lv</b> livermorium –														

lanthanoids

57 <b>La</b> lanthanum 139	58 <b>Ce</b> cerium 140	59 <b>Pr</b> praseodymium 141	60 <b>Nd</b> neodymium 144	61 <b>Pm</b> promethium –	62 <b>Sm</b> samarium 150	63 <b>Eu</b> europium 152	64 <b>Gd</b> gadolinium 157	65 <b>Tb</b> terbium 159	66 <b>Dy</b> dysprosium 163	67 <b>Ho</b> holmium 165	68 <b>Er</b> erbium 167	69 <b>Tm</b> thulium 169	70 <b>Yb</b> ytterbium 173	71 <b>Lu</b> lutetium 175
89 <b>Ac</b> actinium –	90 <b>Th</b> thorium 232	91 <b>Pa</b> protactinium 231	92 <b>U</b> uranium 238	93 <b>Np</b> neptunium –	94 <b>Pu</b> plutonium –	95 <b>Am</b> americium –	96 <b>Cm</b> curium –	97 <b>Bk</b> berkelium –	98 <b>Cf</b> californium –	99 <b>Es</b> einsteinium –	100 <b>Fm</b> fermium –	101 <b>Md</b> mendelevium –	102 <b>No</b> nobelium –	103 <b>Lr</b> lawrencium –

actinoids

The volume of one mole of any gas is 24 dm<sup>3</sup> at room temperature and pressure (r.t.p.).