



Cambridge International Examinations
Cambridge International General Certificate of Secondary Education

CANDIDATE
NAME

CENTRE
NUMBER

--	--	--	--	--

CANDIDATE
NUMBER

--	--	--	--

* 3 4 9 7 1 6 3 9 8 8 *



CHEMISTRY

0620/33

Paper 3 Theory (Core)

May/June 2018

1 hour 15 minutes

Candidates answer on the Question Paper.

No Additional Materials are required.

READ THESE INSTRUCTIONS FIRST

Write your Centre number, candidate number and name on all the work you hand in.

Write in dark blue or black pen.

You may use an HB pencil for any diagrams or graphs.

Do not use staples, paper clips, glue or correction fluid.

DO **NOT** WRITE IN ANY BARCODES.

Answer **all** questions.

Electronic calculators may be used.

A copy of the Periodic Table is printed on page 20.

You may lose marks if you do not show your working or if you do not use appropriate units.

At the end of the examination, fasten all your work securely together.

The number of marks is given in brackets [] at the end of each question or part question.

The syllabus is approved for use in England, Wales and Northern Ireland as a Cambridge International Level 1/Level 2 Certificate.

This document consists of **17** printed pages and **3** blank pages.

1 The names of seven gases are given.

ammonia
ethene
helium
hydrogen
hydrogen chloride
methane
nitrogen

(a) Answer the following questions about these gases.
Each gas may be used once, more than once or not at all.
State which gas:

(i) forms an acidic solution in water

..... [1]

(ii) is monatomic

..... [1]

(iii) forms 78% of clean dry air

..... [1]

(iv) is the main constituent of natural gas

..... [1]

(v) has molecules which each contain 14 protons.

..... [1]

(b) (i) Give the names of **two** elements in the list.

..... and [1]

(ii) What is meant by the term *element*?

..... [1]

- (c) Complete the dot-and-cross diagram to show the electron arrangement in a molecule of hydrogen chloride. Show outer electrons only.

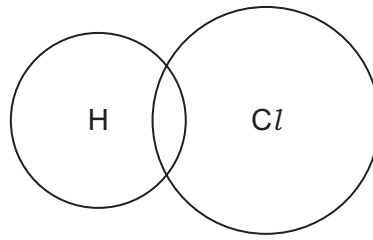

[2]

[Total: 9]

- 2 (a) The table shows the percentage by volume of each of the gases present in the exhaust gases from a petrol engine and a diesel engine.

name	percentage by volume from a petrol engine	percentage by volume from a diesel engine
nitrogen	72.00	67.00
carbon dioxide	14.00	
water vapour	12.00	11.00
carbon monoxide	1.50	0.05
oxides of nitrogen	0.25	0.70
hydrocarbons	0.24	0.22
sulfur dioxide	0.01	0.03
oxygen	0.00	9.00
	total 100.00	total 100.00

- (i) In the diesel engine, nitrogen, carbon dioxide and water vapour account for 90.00% of the exhaust gases by volume.

Calculate the percentage by volume of carbon dioxide in the exhaust gases from the diesel engine.

.....% [1]

- (ii) Describe **three** ways in which the composition of the exhaust gases from the petrol engine differ from the composition of the exhaust gases from the diesel engine.

1

2

3

[3]

- (iii) Give **one** adverse effect of sulfur dioxide on health.

..... [1]

- (b) Complete the sentences about the separation of petroleum into fractions using words from the list.

boiling crystallisation density distillation kerosene poly(ethene)

Fractional of petroleum produces fractions such as gasoline, diesel oil and Within each fraction, the molecules have a particular range of points.

[3]

- (c) Balance the chemical equation for the complete combustion of propane.

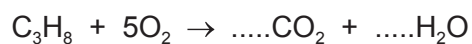

[2]

[Total: 10]

3 This question is about cobalt and its compounds.

- (a) A coloured crystal of cobalt(II) chloride was placed at the bottom of a beaker containing water. After 2 days, the colour had spread throughout the water.

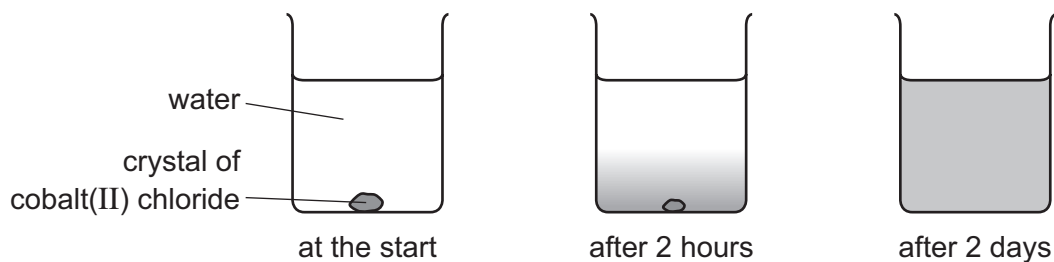

Explain these observations using the kinetic particle model.

.....

.....

.....

.....

.....

..... [3]

- (b) Cobalt(II) chloride can be used to test for the presence of water.

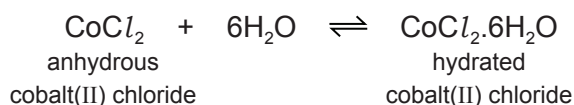

- (i) What is meant by the symbol \rightleftharpoons ?

..... [1]

- (ii) Describe how the colour of anhydrous cobalt(II) chloride changes when water is added to it.

from to

[2]

- (c) A compound of cobalt can be represented by the structure shown.

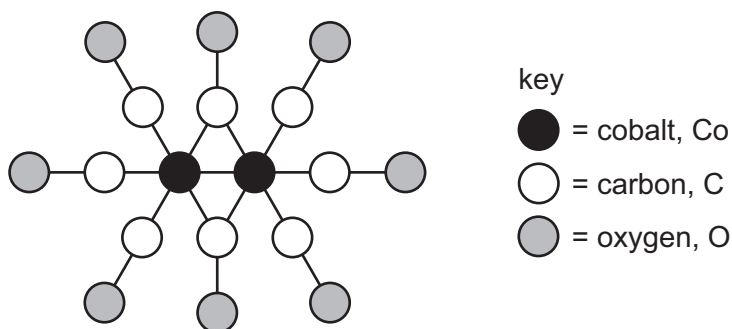

Deduce the molecular formula of this compound showing the number of cobalt, carbon and oxygen atoms.

..... [1]

(d) The table compares the reactivity of cobalt with that of three other metals.

metal	reactivity with cold water	reactivity with steam
barium	reacts rapidly	
cobalt	no reaction	reacts slowly when heated
magnesium	reacts very slowly	reacts rapidly
zinc	no reaction	reacts easily when heated

Use this information to put the metals in order of their reactivity. Put the least reactive metal first.

least reactive $\xrightarrow{\hspace{15em}}$ most reactive

[2]

(e) Cobalt is a transition element. Lithium is an element in Group I of the Periodic Table.

Describe **three** ways in which the properties of cobalt differ from those of lithium.

- 1
- 2
- 3

[2]

(f) When cobalt(II) oxide, CoO, is heated in air, an oxide with the formula Co_3O_4 is formed.

Balance the chemical equation for this reaction.

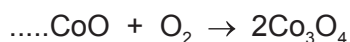

[1]

(g) When Co_3O_4 is heated with hydrogen, cobalt metal can be formed.

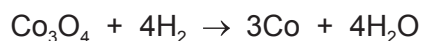

How does this equation show that Co_3O_4 is reduced?

-
- [1]

[Total: 13]

4 This question is about alcohols.

(a) The structure of compound **P** is shown.

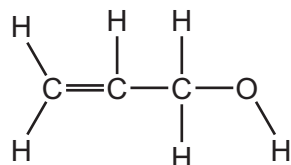

(i) What feature of the structure of compound **P** shows that it is unsaturated?

..... [1]

(ii) Describe how the colour of aqueous bromine changes when an excess of compound **P** is added to it.

from to [2]

(iii) The melting point of compound **P** is -129°C .
The boiling point of compound **P** is 97°C .

What is the physical state of compound **P** at -120°C ?
Explain your answer.

..... [2]
.....

(b) Ethanol is an alcohol with two carbon atoms.

(i) Draw the structure of ethanol showing all of the atoms and all of the bonds.

[1]

- (ii) Ethanol can be manufactured by fermentation.

Complete the sentences about fermentation using words from the list.

30 °C 300 °C distillation electrolysis
 elements enzymes salt sugar

A flask containing solution and yeast is heated to

The yeast contains which catalyse the reaction. The ethanol is separated by [4]

- (iii) Ethanol can be used as a fuel.

Give **one** other use of ethanol in industry.

..... [1]

- (iv) The energy level diagram for the complete combustion of ethanol is shown.

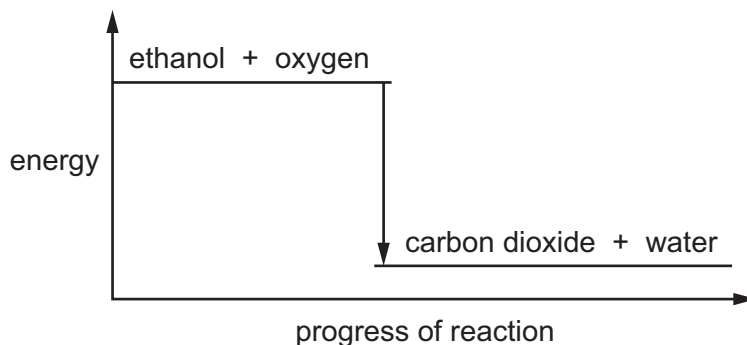

Explain how this diagram shows that the reaction is exothermic.

..... [1]

- (v) Carbon dioxide and water can be formed when ethanol burns in a limited supply of air.

State the name of **two** other products which can be formed when ethanol burns in a limited supply of air.

..... and [2]

[Total: 14]

5 (a) Molten lead(II) bromide can be electrolysed using the apparatus shown.

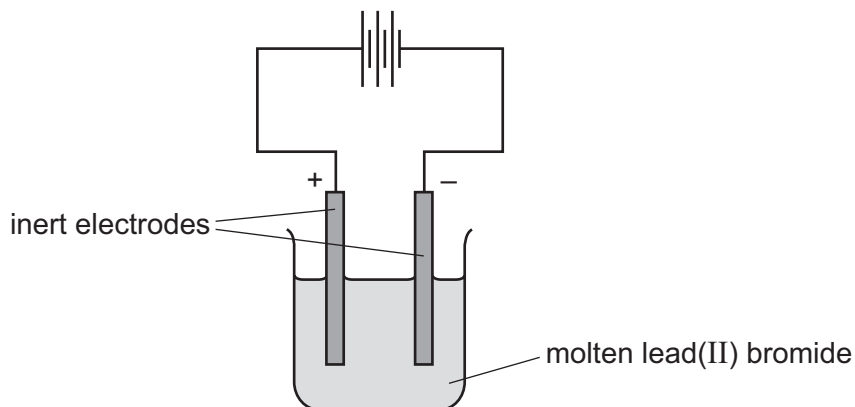

The negative electrode is called the cathode.

State the name of the positive electrode.

..... [1]

(b) Predict the products of the electrolysis of molten lead(II) bromide at:

the negative electrode

the positive electrode.

[2]

(c) Lead(II) bromide is insoluble in cold water.
Sodium bromide is soluble in cold water.

Describe how you could obtain crystals of sodium bromide from a mixture of solid lead(II) bromide and solid sodium bromide.

.....

 [3]

(d) When chlorine is bubbled through a colourless aqueous solution of sodium bromide, the solution turns orange-brown.

Name the orange-brown substance. Suggest, using ideas about reactivity of the halogens, why the reaction occurs.

orange-brown substance

why the reaction occurs

[2]

(e) What is the colour of the precipitate formed when aqueous silver nitrate is added to aqueous sodium bromide?

..... [1]

(f) Complete the sentence about the formation of a chloride ion from a chlorine atom.

A chloride ion is formed when a chlorine atom gains one [1]

[Total: 10]

6 This question is about isotopes.

(a) An atom of an isotope of oxygen is represented by the symbol shown.



Describe the structure of an atom of this isotope of oxygen.

In your answer, include:

- the position of the protons, neutrons and electrons in the atom
- the number of protons, neutrons and electrons present in the atom.

.....

.....

.....

.....

.....

.....

.....

.....

..... [5]

(b) Which **two** statements about isotopes are correct?
Tick **two** boxes.

Isotopes of the same element have different numbers of protons.

Isotopes of the same element have different numbers of neutrons.

Isotopes are always radioactive.

The isotope ${}^{235}_{92}\text{U}$ is a source of energy.

${}^{14}_6\text{C}$ and ${}^{14}_7\text{N}$ are isotopes of each other.

[2]

(c) What is meant by the term *nucleon number*?

.....

..... [1]

[Total: 8]

7 This question is about Group I elements and their compounds.

(a) The properties of some Group I elements are shown in the table.

element	melting point / °C	relative hardness	observations when it reacts with cold water
lithium	181	23	
sodium	98	3	rapid bubbling but does not burst into flame
potassium	63		very rapid bubbling and bursts into flame
rubidium		1	bursts into flame and explodes

(i) Complete the table to estimate:

- the relative hardness of potassium
- the melting point of rubidium.

[2]

(ii) Use the information in the table to predict what you would observe when lithium reacts with cold water.

..... [1]

(b) Write the electronic structure of a sodium atom.

..... [1]

(c) When sodium reacts with water, an alkaline solution is formed.

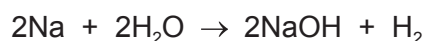

(i) Use the information in the equation to explain why the solution formed is alkaline.

..... [1]

(ii) Describe how you could use a named indicator solution to show that the solution is alkaline.

.....
 [2]

(d) Sodium tetrahydridoborate, NaBH_4 , is an ionic compound.

Calculate the relative formula mass of NaBH_4 .

Show all your working.

Use your Periodic Table to help you.

relative formula mass = [2]

[Total: 9]

- 8 The apparatus shown is used to investigate the rate of reaction between calcium carbonate and hydrochloric acid at 30 °C.

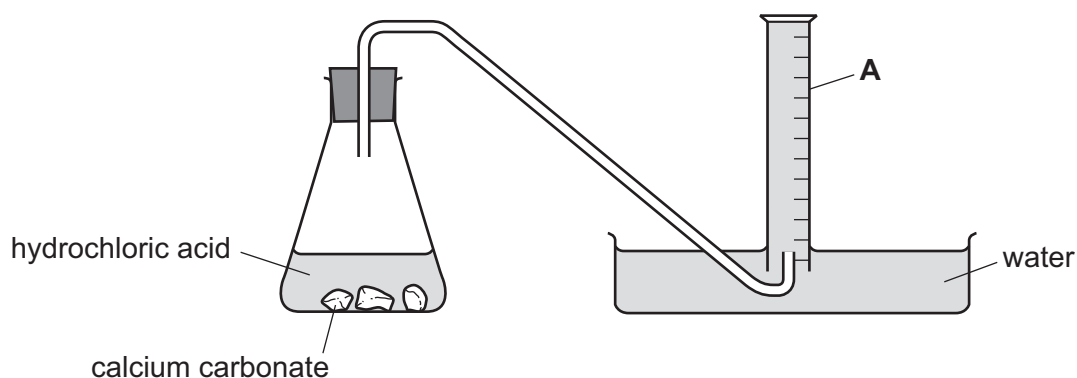

- (a) Name the piece of apparatus labelled **A** in the diagram.

..... [1]

- (b) Describe how this apparatus can be used to find the rate of reaction.

.....

 [2]

- (c) The experiment is repeated at 20 °C. All other conditions are kept the same.

How does the decrease in temperature affect the rate of reaction?

..... [1]

- (d) The experiment is repeated using the same mass of different size pieces of calcium carbonate. All other conditions are kept the same.

The sizes of the pieces of calcium carbonate are:

- large pieces
- small pieces
- powder

Complete the table by writing the sizes of the pieces in the first column.

size of the pieces of calcium carbonate	initial rate of reaction in cm ³ gas/s
	5
	2
	12

[1]

(e) Give the names of the **three** products formed when calcium carbonate reacts with hydrochloric acid.

1

2

3

[2]

[Total: 7]

BLANK PAGE

Permission to reproduce items where third-party owned material protected by copyright is included has been sought and cleared where possible. Every reasonable effort has been made by the publisher (UCLES) to trace copyright holders, but if any items requiring clearance have unwittingly been included, the publisher will be pleased to make amends at the earliest possible opportunity.

To avoid the issue of disclosure of answer-related information to candidates, all copyright acknowledgements are reproduced online in the Cambridge International Examinations Copyright Acknowledgements Booklet. This is produced for each series of examinations and is freely available to download at www.cie.org.uk after the live examination series.

Cambridge International Examinations is part of the Cambridge Assessment Group. Cambridge Assessment is the brand name of University of Cambridge Local Examinations Syndicate (UCLES), which is itself a department of the University of Cambridge.

The Periodic Table of Elements

Group																												
I	II											III	IV	V	VI	VII	VIII											
<p style="text-align: center;">Key</p> <div style="border: 1px solid black; padding: 5px; width: fit-content; margin: auto;"> atomic number atomic symbol name relative atomic mass </div>												1 H hydrogen 1																2 He helium 4
												3 Li lithium 7	4 Be beryllium 9											5 B boron 11	6 C carbon 12	7 N nitrogen 14	8 O oxygen 16	9 F fluorine 19
11 Na sodium 23	12 Mg magnesium 24											13 Al aluminium 27	14 Si silicon 28	15 P phosphorus 31	16 S sulfur 32	17 Cl chlorine 35.5	18 Ar argon 40											
19 K potassium 39	20 Ca calcium 40	21 Sc scandium 45	22 Ti titanium 48	23 V vanadium 51	24 Cr chromium 52	25 Mn manganese 55	26 Fe iron 56	27 Co cobalt 59	28 Ni nickel 59	29 Cu copper 64	30 Zn zinc 65	31 Ga gallium 70	32 Ge germanium 73	33 As arsenic 75	34 Se selenium 79	35 Br bromine 80	36 Kr krypton 84											
37 Rb rubidium 85	38 Sr strontium 88	39 Y yttrium 89	40 Zr zirconium 91	41 Nb niobium 93	42 Mo molybdenum 96	43 Tc technetium –	44 Ru ruthenium 101	45 Rh rhodium 103	46 Pd palladium 106	47 Ag silver 108	48 Cd cadmium 112	49 In indium 115	50 Sn tin 119	51 Sb antimony 122	52 Te tellurium 128	53 I iodine 127	54 Xe xenon 131											
55 Cs caesium 133	56 Ba barium 137	57–71 lanthanoids	72 Hf hafnium 178	73 Ta tantalum 181	74 W tungsten 184	75 Re rhenium 186	76 Os osmium 190	77 Ir iridium 192	78 Pt platinum 195	79 Au gold 197	80 Hg mercury 201	81 Tl thallium 204	82 Pb lead 207	83 Bi bismuth 209	84 Po polonium –	85 At astatine –	86 Rn radon –											
87 Fr francium –	88 Ra radium –	89–103 actinoids	104 Rf rutherfordium –	105 Db dubnium –	106 Sg seaborgium –	107 Bh bohrium –	108 Hs hassium –	109 Mt meitnerium –	110 Ds darmstadtium –	111 Rg roentgenium –	112 Cn copernicium –			114 Fl flerovium –			116 Lv livermorium –											

lanthanoids	57 La lanthanum 139	58 Ce cerium 140	59 Pr praseodymium 141	60 Nd neodymium 144	61 Pm promethium –	62 Sm samarium 150	63 Eu europium 152	64 Gd gadolinium 157	65 Tb terbium 159	66 Dy dysprosium 163	67 Ho holmium 165	68 Er erbium 167	69 Tm thulium 169	70 Yb ytterbium 173	71 Lu lutetium 175
actinoids	89 Ac actinium –	90 Th thorium 232	91 Pa protactinium 231	92 U uranium 238	93 Np neptunium –	94 Pu plutonium –	95 Am americium –	96 Cm curium –	97 Bk berkelium –	98 Cf californium –	99 Es einsteinium –	100 Fm fermium –	101 Md mendelevium –	102 No nobelium –	103 Lr lawrencium –

The volume of one mole of any gas is 24 dm³ at room temperature and pressure (r.t.p.).