



Cambridge International Examinations
Cambridge International General Certificate of Secondary Education

GEOGRAPHY

0460/43

Paper 4 Alternative to Coursework

May/June 2018

INSERT

1 hour 30 minutes

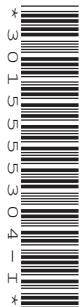

READ THESE INSTRUCTIONS FIRST

This Insert contains Figs. 1.1 and 1.6 and Table 1.1 for Question 1, and Figs. 2.1, 2.4 and 2.8 and Tables 2.2 and 2.3 for Question 2.

The Insert is **not** required by the Examiner.

This syllabus is approved for use in England, Wales and Northern Ireland as a Cambridge International Level 1/Level 2 Certificate.

This document consists of **8** printed pages and **4** blank pages.

Fig. 1.1 for Question 1

Rain gauge and measuring cylinder

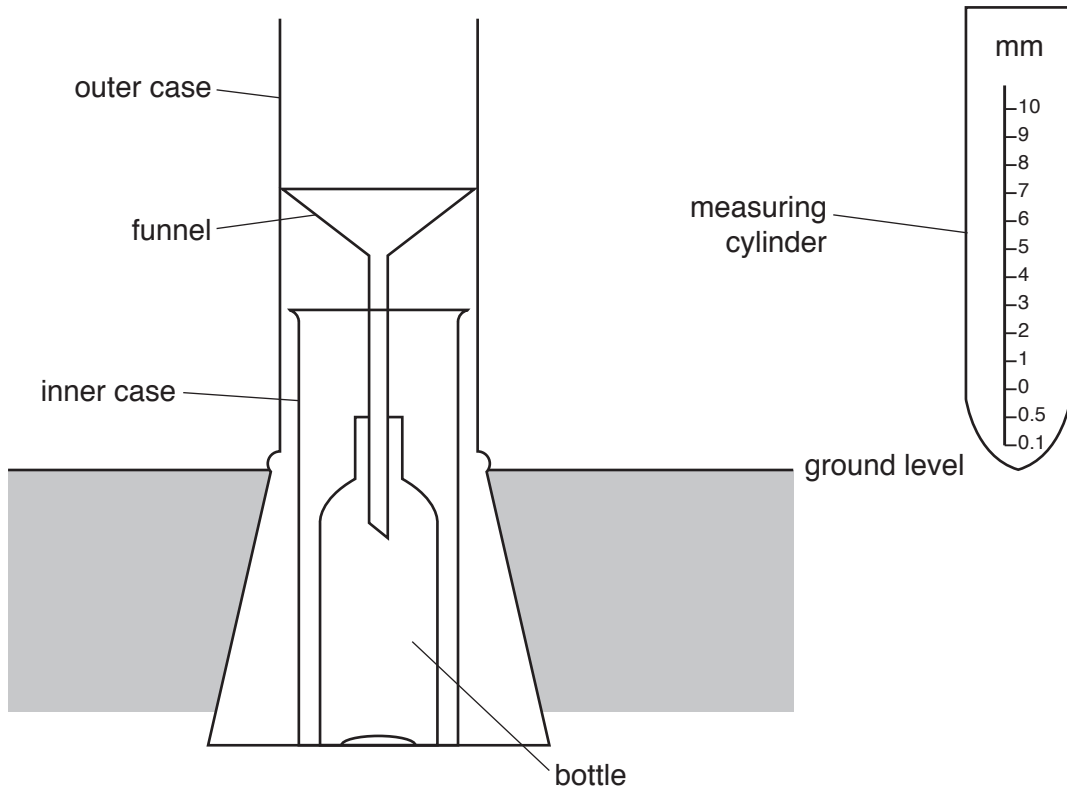

Table 1.1 for Question 1

Atmospheric pressure data collected by students in February of the current year and from February of the previous year

Data collected by students in February	
Date	Atmospheric pressure (mb)
1st	1003
2nd	1003
3rd	985
4th	977
5th	980
6th	990
7th	987
8th	982
9th	990
10th	990
11th	987
12th	989
13th	976
14th	984
15th	1007
16th	996
17th	1008
18th	1012
19th	999
20th	1003
21st	1008
22nd	1008
23rd	993
24th	997
25th	992
26th	995
27th	994
28th	988

Data collected in February of the previous year	
Date	Atmospheric pressure (mb)
1st	1000
2nd	1007
3rd	1006
4th	1015
5th	1026
6th	1031
7th	1036
8th	1040
9th	1035
10th	1034
11th	1003
12th	1021
13th	1025
14th	1000
15th	1013
16th	1013
17th	1036
18th	1022
19th	1039
20th	1008
21st	1001
22nd	1000
23rd	997
24th	1002
25th	1013
26th	1010
27th	1020
28th	1010

Fig. 1.6 for Question 1

Results of measurements of wind direction and average daily temperature

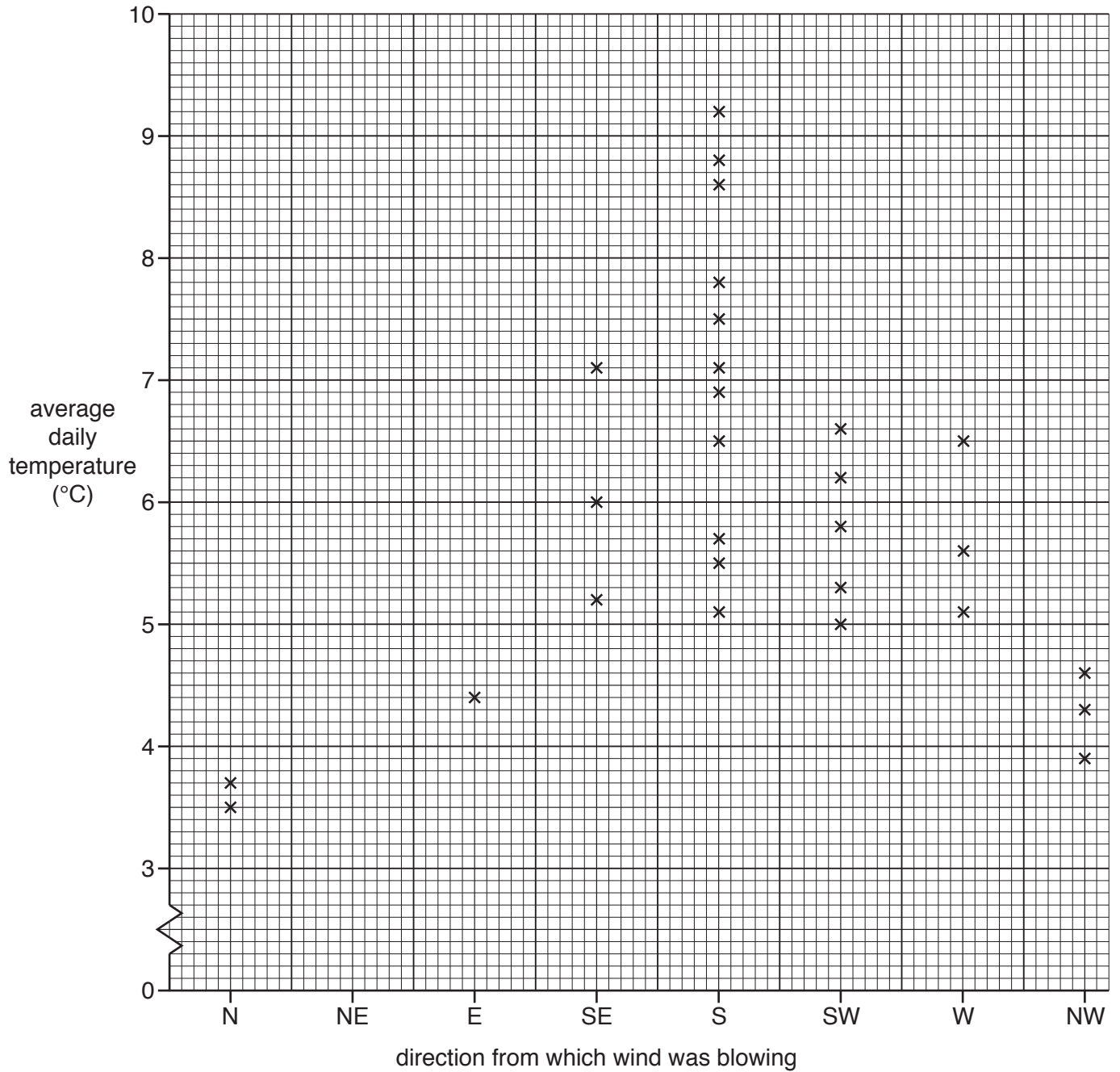

Fig. 2.1 for Question 2

Extract from a student's notebook

Measuring the pH of water

pH is a measure of the acidity of water. The pH score decreases as water becomes more acidic. More acidic water is more likely to be polluted.

- 1 Collect a sample of water in a clean container.
- 2 Put the probe of the pH meter into the water.
- 3 Read the digital display.
- 4 Take three samples of water and test each one.

Measuring the clarity of water

This is a test to measure how clear the water is.

- 1 Put the measuring tape attached to the disk into the water.
- 2 Slowly lower the measuring tape into the water.
- 3 When the disk can no longer be seen record the measurement on the tape at the water surface. This shows how deep the disk is in the water.
- 4 Repeat the test three times and record each result.



Table 2.2 for Question 2

Results of pH measurements

	pH reading			
	test 1	test 2	test 3	Average
site 1	6.1	6.0	6.2	6.1
site 2	5.8	5.6	5.9	5.8
site 3	5.4	5.5	5.5	5.5

Table 2.3 for Question 2

Results of water clarity measurements

	depth of clear water (cm)			
	test 1	test 2	test 3	Average
site 1	39	38	38	38.3
site 2	33	34	38	35.0
site 3	13	19	18	16.7

BLANK PAGE

Fig. 2.4 for Question 2

Environmental quality recording sheet

	Positive description	+2	+1	0	-1	-2	Negative description
Buildings	in good condition						in poor condition
	well-designed / attractive						poorly designed / ugly
	well maintained						poorly maintained
	no vandalism or graffiti						extensive vandalism or graffiti
Open space	large private gardens						no private gardens
	lots of trees, bushes or grass						no trees, bushes or grass
	parks are well maintained						parks are poorly maintained
	no litter and debris						much litter and debris
Traffic	no traffic congestion						roads are badly congested
	little traffic noise						very noisy from traffic
	no air pollution from traffic fumes						air is badly polluted from traffic fumes
	safe for people to cross roads						dangerous for people to cross roads
General	roads and pavements are well maintained						roads and pavements are poorly maintained
	few road signs or advertising boards						lots of road signs and advertising boards
	lakes and streams are clean						lakes and streams are dirty
	lots of insects and wildlife can be seen						no evidence of insects and wildlife

Fig. 2.8 for Question 2

Completed environmental quality recording sheet for undeveloped site

	Positive description	+2	+1	0	-1	-2	Negative description
Buildings	in good condition	NO BUILDINGS					in poor condition
	well-designed / attractive						poorly designed / ugly
	well maintained						poorly maintained
	no vandalism or graffiti						extensive vandalism or graffiti
Open space	large private gardens			✓			no private gardens
	lots of trees, bushes or grass	✓					no trees, bushes or grass
	parks are well maintained	✓					parks are poorly maintained
	no litter and debris	✓					much litter and debris
Traffic	no traffic congestion	✓					roads are badly congested
	little traffic noise	✓					very noisy from traffic
	no air pollution from traffic fumes	✓					air is badly polluted from traffic fumes
	safe for people to cross roads	✓					dangerous for people to cross roads
General	roads and pavements are well maintained			✓			roads and pavements are poorly maintained
	few road signs or advertising boards	✓					lots of road signs and advertising boards
	lakes and streams are clean	✓					lakes and streams are dirty
	lots of insects and wildlife can be seen	✓					no evidence of insects and wildlife

BLANK PAGE

Permission to reproduce items where third-party owned material protected by copyright is included has been sought and cleared where possible. Every reasonable effort has been made by the publisher (UCLES) to trace copyright holders, but if any items requiring clearance have unwittingly been included, the publisher will be pleased to make amends at the earliest possible opportunity.

To avoid the issue of disclosure of answer-related information to candidates, all copyright acknowledgements are reproduced online in the Cambridge International Examinations Copyright Acknowledgements Booklet. This is produced for each series of examinations and is freely available to download at www.cie.org.uk after the live examination series.

Cambridge International Examinations is part of the Cambridge Assessment Group. Cambridge Assessment is the brand name of University of Cambridge Local Examinations Syndicate (UCLES), which is itself a department of the University of Cambridge.