

date

Centre Number

Candidate Name _____

**International General Certificate of Secondary Education
CAMBRIDGE INTERNATIONAL EXAMINATIONS**

DESIGN AND TECHNOLOGY

PAPER 4 Technology

0445/4

OCTOBER/NOVEMBER SESSION 2002

1 hour

Candidates answer on the question paper.
No additional materials are required.

TIME 1 hour

To be taken together with Paper 1 in one session of 2 hours 45 minutes.

INSTRUCTIONS TO CANDIDATES

Write your name, Centre number and candidate number in the spaces at the top of this page.

Answer any **two** questions.

Write your answers in the spaces provided on the question paper.

INFORMATION FOR CANDIDATES

The number of marks is given in brackets [] at the end of each question or part question.

You may use a calculator.

FOR EXAMINER'S USE

1	
2	
3	
4	
TOTAL	

1 Fig. 1 shows a design for a trailer to be towed by a bicycle.

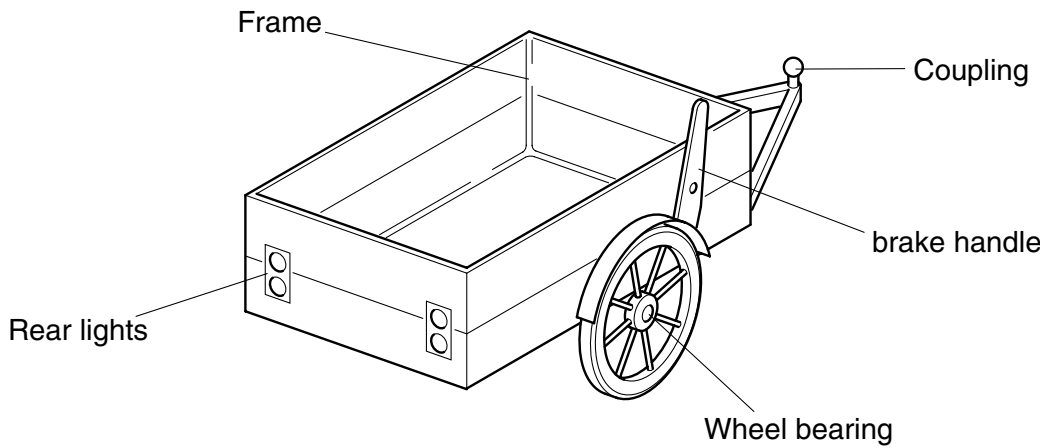
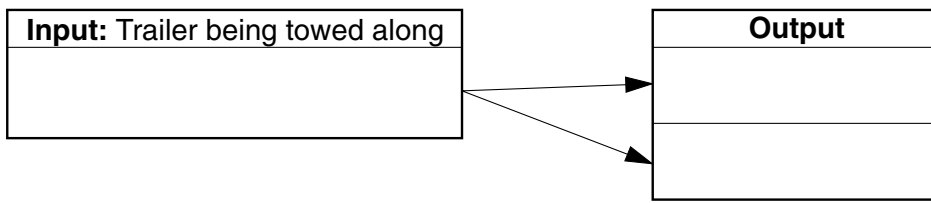

Fig. 1

(a) (i) Complete the block diagram below showing the energy conversions that take place when the trailer is being towed along.



[3]

(ii) Explain how energy from the towed trailer wheel could be converted to power the rear lights of the trailer.

.....

.....

.....[2]

(iii) A battery could be used as an energy source for the rear lights. Circle the word below that best describes a battery as a type of energy source.

direct secondary natural [1]

(iv) Explain **one** main factor that makes the trailer energy inefficient.

.....

.....

.....[2]

(v) Suggest **one** way of overcoming the factor you have described in your answer to (a) (iv).

.....
.....
.....[2]

(b) The trailer has a parking brake applied by a handle mounted on the side of the trailer.

(i) Explain why it is helpful to the user to have a long brake handle.

.....
.....
.....[2]

(ii) Add notes and sketches to the diagram below to show how the parking brake could be locked in position for parking.

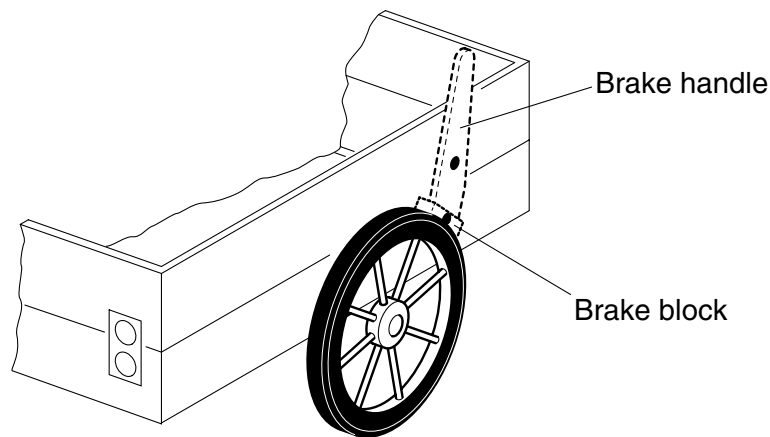

[5]

(iii) Explain how models could be used to develop the design of the braking system.

.....
.....
.....[3]

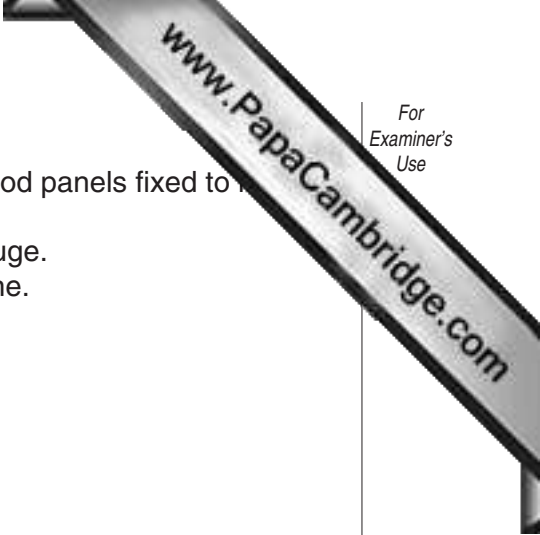

- (c) The body of the trailer is made from a metal frame with plywood panels fixed to it.
 - (i) The frame is to be tested for deflection using a strain gauge. Use notes and sketches to explain how this could be done.

[4]

- (ii) State an alternative way of accurately measuring deflection.

.....[1]

- (iii) Explain **one** way that the frame could be modified to reduce deflection.

.....

.....

.....[2]

- (iv) Sketch and label a suitable cross-section for the metal frame parts.

[2]

- (v) Give **one** reason for your chosen section shape in (c) (iv).

.....

.....[1]

2 Fig. 2 shows detail of the student's design for a coupling to link the trailer to the bicycle.

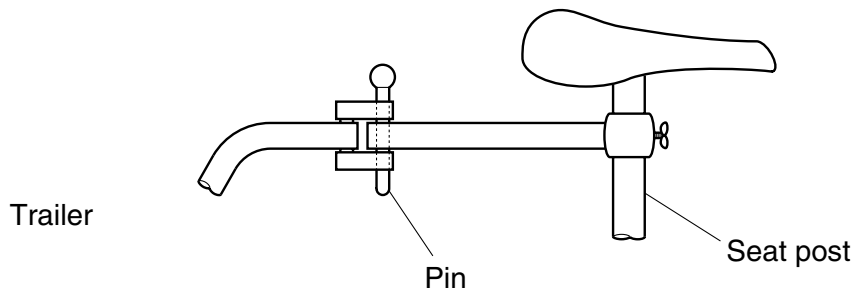

Fig. 2

(a) (i) Give **one** benefit of this method.

.....
[1]

(ii) Give **one** drawback of this method.

.....
[1]

(iii) It is decided to replace this coupling with a universal joint.
Use sketches and notes to show a universal joint.

[3]

(iv) The pin in the coupling in Fig. 2 experiences shear force.
Explain what is meant by shear force.

.....

[2]

- (v) The pin is made from mild steel, an elastic material. Explain the term elastic in this situation.

.....

.....

.....

.....

.....[2]

- (b) Fig. 3 shows a stress / strain graph for mild steel.

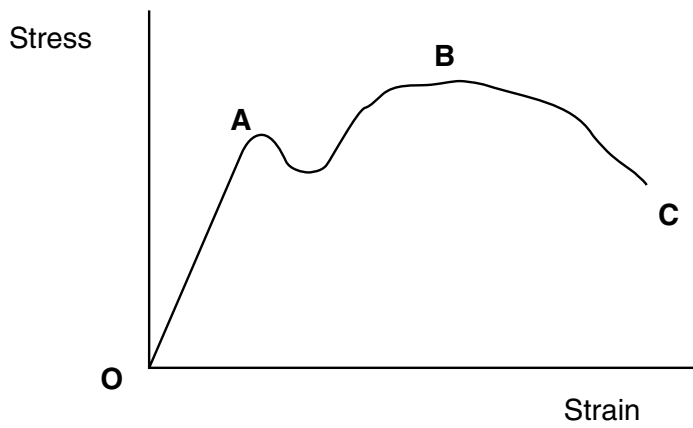

Fig. 3

- (i) Explain what is happening to the material between O and A.

.....

.....

.....

.....

.....[2]

- (ii) Explain what is happening to the material between A and B.

.....

.....

.....

.....

.....[2]

(iii) Explain what is happening to the material at the point C.

.....
.....
.....
.....[2]

(iv) During a tensile test on the coupling pin it is found to extend by 0.00125 mm. Its original length was 80 mm. Calculate the strain on the pin.

.....
.....
.....
.....[3]

(v) Explain the term stress as applied to structures.

.....
.....
.....
.....[2]

(c) Fig. 4 shows the trailer.

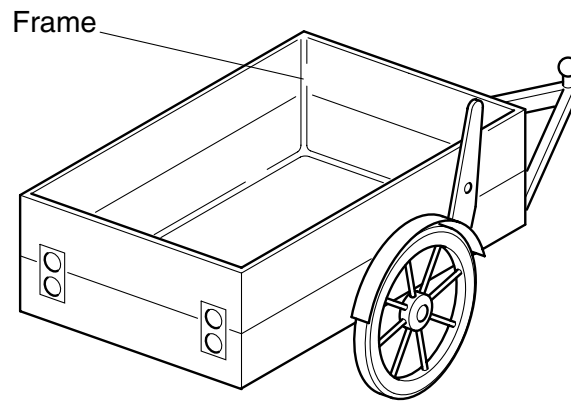

Fig. 4

- (i) The frame could be joined using several different methods. Complete the table below comparing three different joining methods appropriate to this situation.

method	benefit	drawback
Welding	Very strong and permanent.	
Nut and bolt		Could work loose with vibration.
Riveting	Quick.	

[3]

- (ii) Plywood panels are to be fixed to the framework. Use sketches and notes to show how this is done using nuts and bolts.

[3]

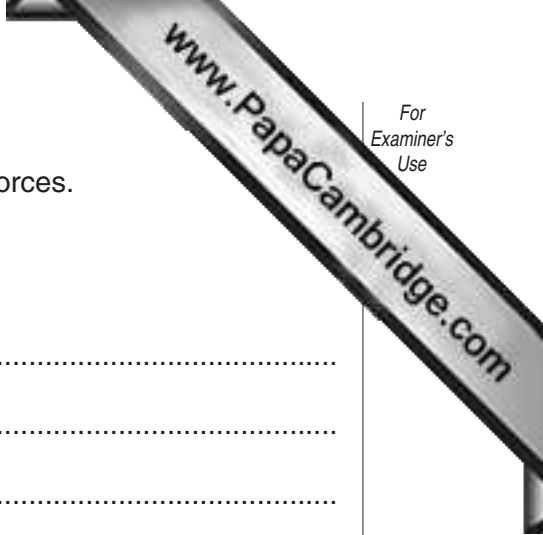

(iii) The frame of the trailer is subjected to different internal forces.
Explain what is meant by the following terms:

torsion force;

.....
.....
.....
.....[2]

static loading.

.....
.....
.....
.....[2]

3 Wheel bearings are needed for the trailer wheels.

(a) (i) Explain the need for bearings.

.....

.....

.....

.....[2]

(ii) Complete the table below comparing different types of bearing.

type of bearing	uses	reason for use
Plain		Simple, effective for moderate loads and speeds.
Ball	Cycle wheels, electric drills.	
Roller	Motor vehicles, heavy machinery.	

[6]

(iii) Fig. 5 shows a cutaway view of a ball bearing. Name the parts labelled on Fig. 5.

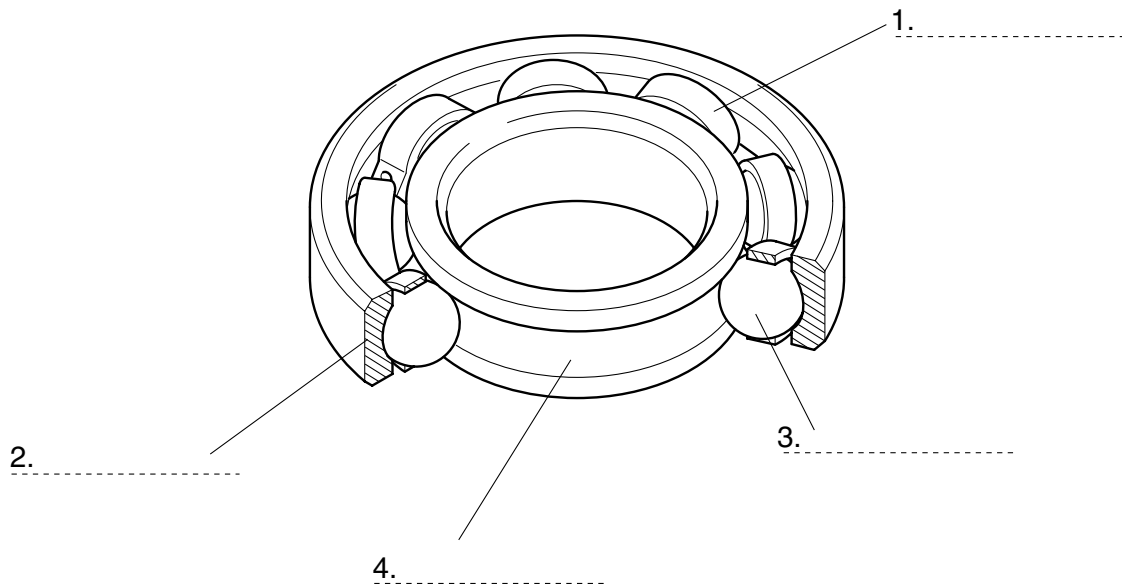

Fig. 5

[4]

(b) It is important to lubricate the trailer bearings and coupling.

(i) Explain the need for lubrication in this situation.

.....
.....
.....
.....[2]

(ii) Fig. 6 shows a gravity feed method of lubricating a plain bearing.

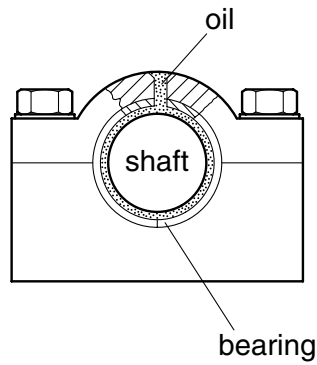

Fig. 6

Give **one** drawback to this method and suggest **one** way of overcoming this drawback:

drawback;

.....
.....[1]

way of overcoming drawback.

.....
.....
.....
.....[2]

(iii) A food mixer also has bearings but these may **not** require lubrication. Explain why this is the case.

.....
.....
.....
.....[2]

(iv) As well as gravity feed lubrication methods there are two other main lubrication methods. These are, splash lubrication and force-feed lubrication. Give **one** example of the use of each of these methods:

splash lubrication;

.....
.....[1]

force-feed lubrication.

.....
.....[1]

(v) Force feed lubrication systems often include an oil filter. Give **one** reason for the use of an oil filter.

.....
.....
.....[1]

- (c) It is decided to have a hinged tailgate on the trailer. A cam operated locking device be used to hold the tailgate in various positions.
- (i) Add sketches and notes to Fig.7 to show how a cam could be used to lock the tailgate into different positions.

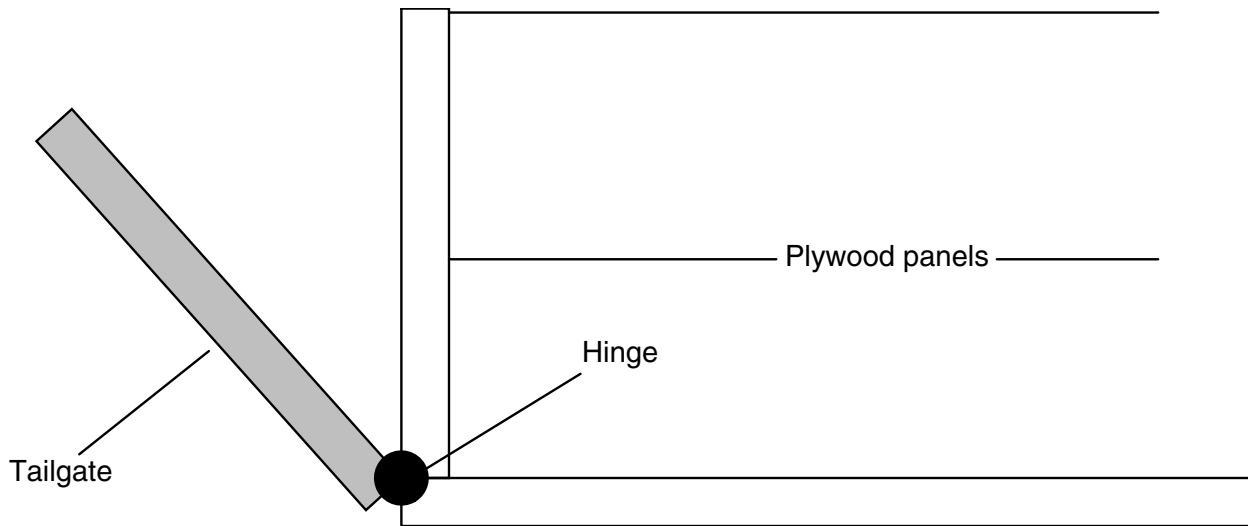

Fig. 7

- (ii) Cams are used to convert motion from one type to another. Fig. 8 shows a pear-shaped cam.
Add labels to Fig. 8 to show how the cam converts rotary to reciprocating motion.
Clearly label the follower.

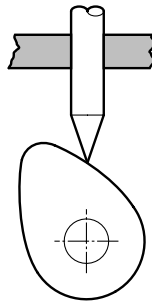

Fig. 8

[3]

- (iii) Give **one** other type of motion.

.....[1]

- 4 It is decided to have flashing indicator lights on the rear of the trailer to indicate left and right turning. Fig. 9 shows an incomplete circuit diagram for a flashing light circuit.

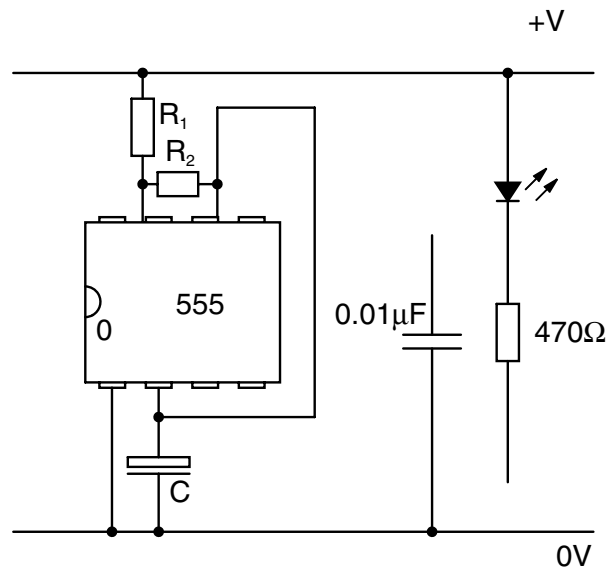
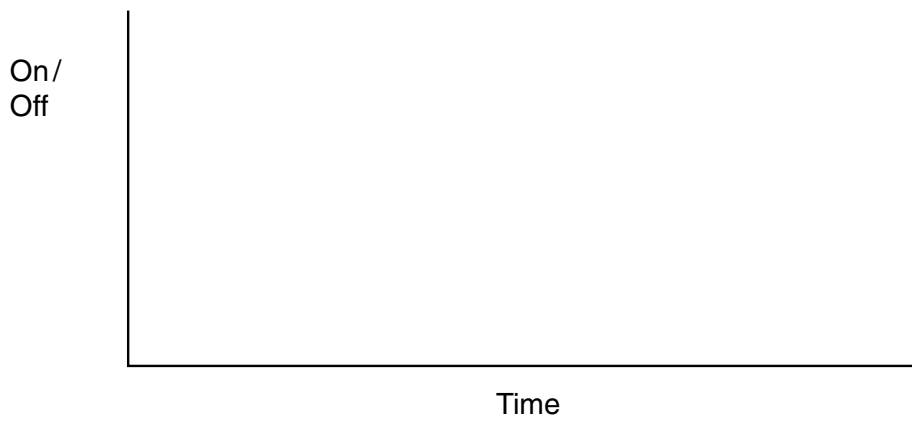

Fig. 9

- (a) (i) Complete the circuit diagram shown in Fig. 9. [5]
- (ii) For the on/off frequency of the flashing light in the above circuit R_1 and R_2 are equal. This means that the mark space ratio is 1:1. Draw, on the axis provided, a diagram of the mark space ratio for this circuit.



- (iii) Number clearly the pins of the 555 integrated circuit in Fig. 9. [2]

(b) One circuit will drive each of the indicator bulbs. A switch is needed to change between each bulb.

(i) Name the type of switch suitable for this application and draw the circuit symbol for it.

Name

Symbol

[3]

(ii) Switches come in a variety of forms with different mechanical actions. Circle the switch action most appropriate for changing from one bulb to the other when turning left or right.

Toggle **Rocker** **Slide** [1]

(iii) Give **one** reason for your choice of switch in part (b) (ii).

.....
.....[1]

(iv) If the circuit in Fig. 9 was used to control a large current device, a relay would be used as an interface. Fig. 10 shows a schematic view of a relay. Use the words from the list below to label Fig. 10.

contacts **electromagnet** **connecting plate** **pivot**

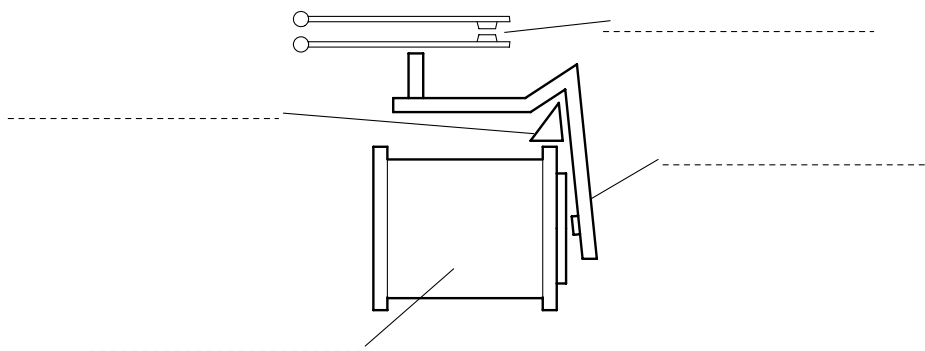

Fig. 10

[4]

- (v) A relay is an electromagnetic device.
Name **one** other example of an electromagnetic device.

.....[1]

- (c) A 9 V battery is used to power the bulbs. The current flowing is 0.06 A.
Calculate the power rating of the circuit.

[3]

- (d) Complete the block diagram below to show the trailer lighting system.

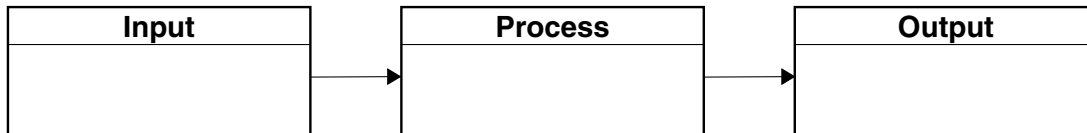

[3]

- (e) An LED is to be used as a battery test indicator for the trailer lighting system. A circuit diagram is shown in Fig. 11.

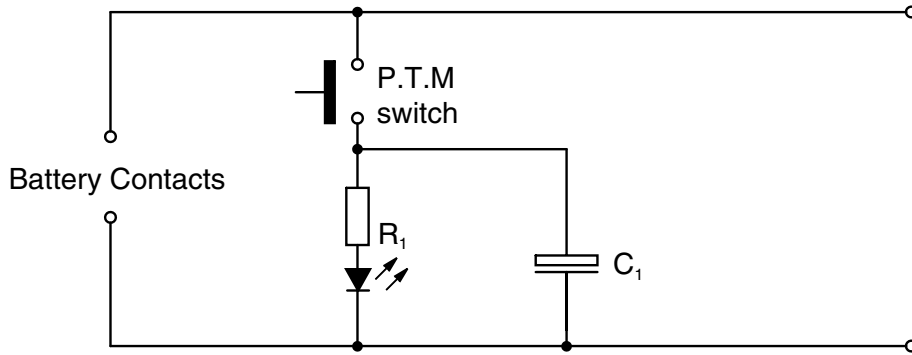

Fig. 11

- (i) State the type of switch shown in the circuit diagram in Fig. 11.

.....[1]

- (ii) State the purpose of R_1 in the circuit diagram in Fig. 11.

.....[1]

- (iii) Explain the purpose of the capacitor C_1 in the circuit diagram shown in Fig. 11.

.....

.....

.....[2]

