

Centre Number	Candidate Number	Name
---------------	------------------	------

CAMBRIDGE INTERNATIONAL EXAMINATIONS
International General Certificate of Secondary Education

DESIGN AND TECHNOLOGY

0445/04

Paper 4 Technology

October/November 2003

1 hour

Candidates answer on the Question Paper.
No additional materials required.

To be taken together with Paper 1 in one session of 2 hours 45 minutes.

READ THESE INSTRUCTIONS FIRST

Write your Centre number, candidate number and name on all the work you hand in.
Write in dark blue or black pen in the spaces provided on the Question Paper.
You may use a soft pencil for any diagrams, graphs or rough working.
Do not use staples, paper clips, highlighters, glue or correction fluid.

Answer any **two** questions.
The number of marks is given in brackets [] at the end of each question or part question.
You may use a calculator.

If you have been given a label, look at the details. If any details are incorrect or missing, please fill in your correct details in the space given at the top of this page.

Stick your personal label here, if provided.

For Examiner's Use	
1	
2	
3	
4	
TOTAL	

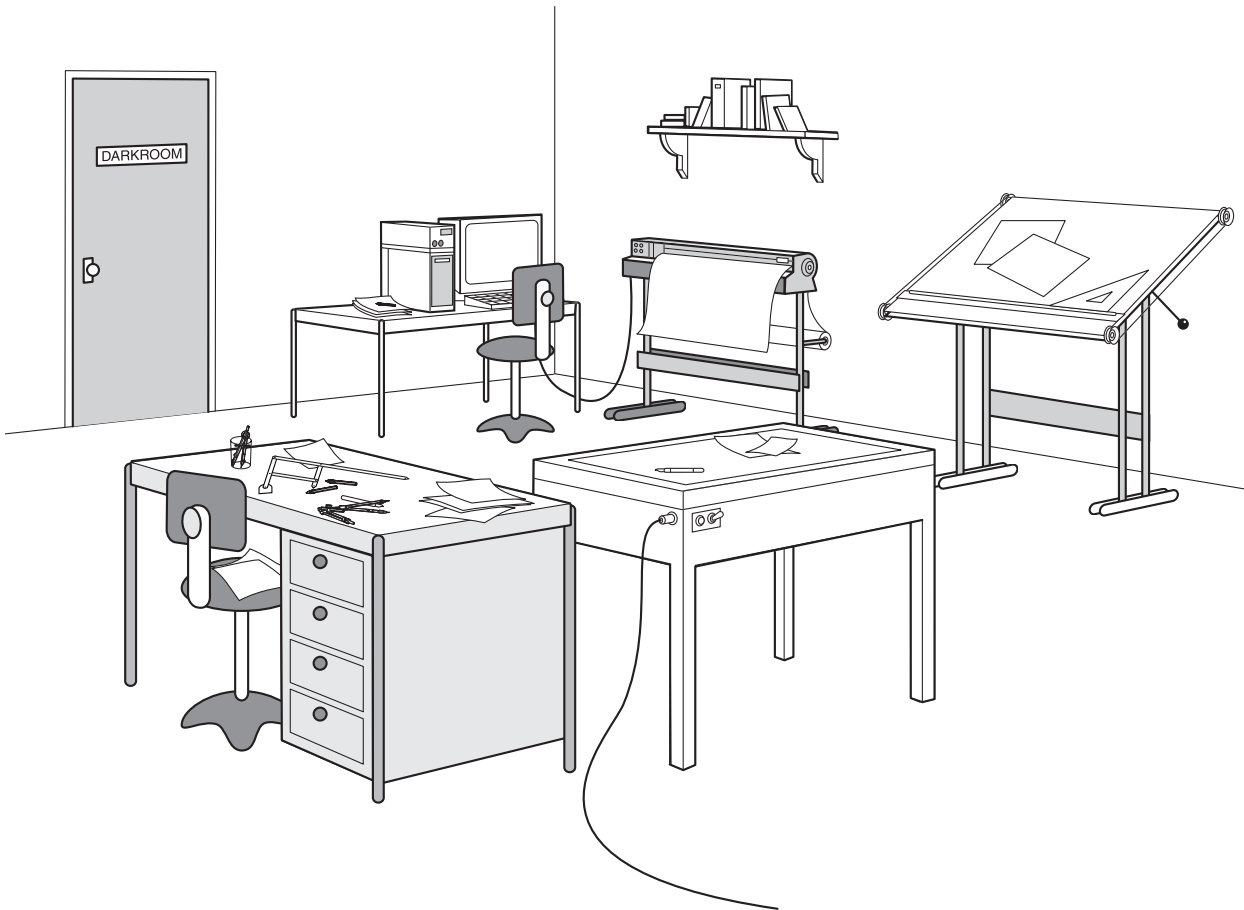

Fig. 1

Fig. 1 shows a photographic darkroom with some equipment in it.

1 (a) Fig. 2 shows an exploded diagram of a pair of compasses.

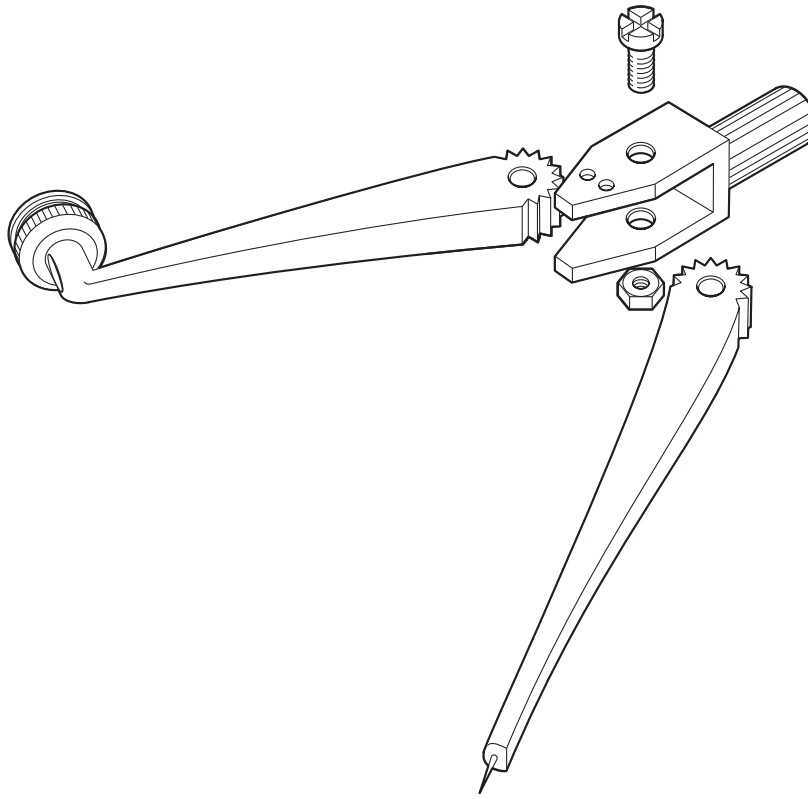

Fig. 2

(i) Add labels to Fig. 2 to show the following mechanisms:

- gears;
- cam;
- screw.

[3]

(ii) Explain the purpose of each of these mechanisms in the use of the compasses.

gears:

.....

.....

..... [3]

cam:

.....

.....

..... [3]

screw:
.....
.....
..... [3]

(iii) Fig. 3 shows two different types of compass.

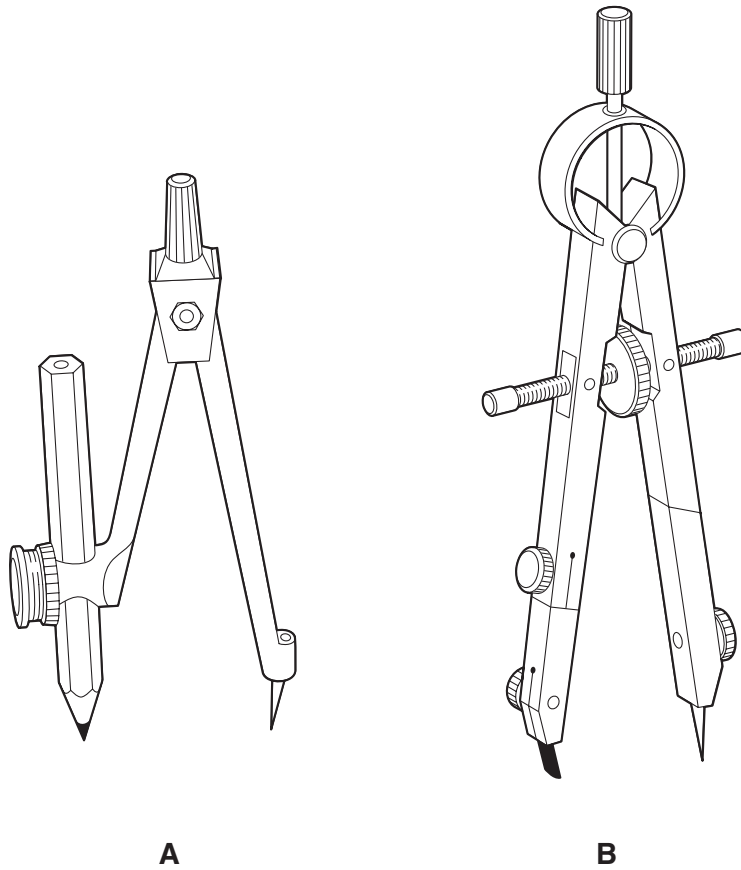

Fig. 3

Compare each one in terms of accuracy. Give reasons for your answers.

.....
.....
.....
..... [2]

- (iv) Use notes and sketches to show how the compasses shown in Fig. 4 can be modified to hold a felt-tipped pen.

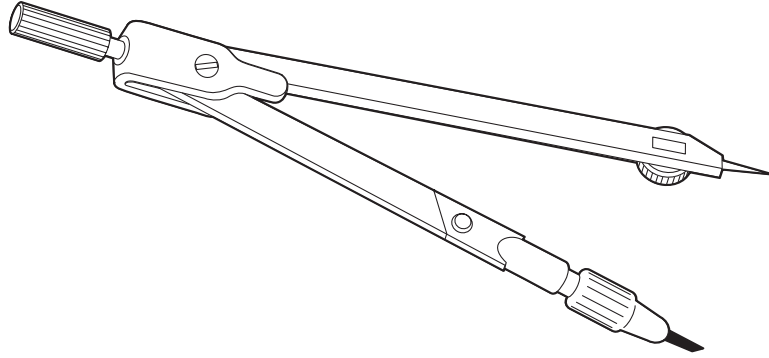

Fig. 4

[4]

(b) Fig. 5 shows details of part of a mechanism for a plotter.

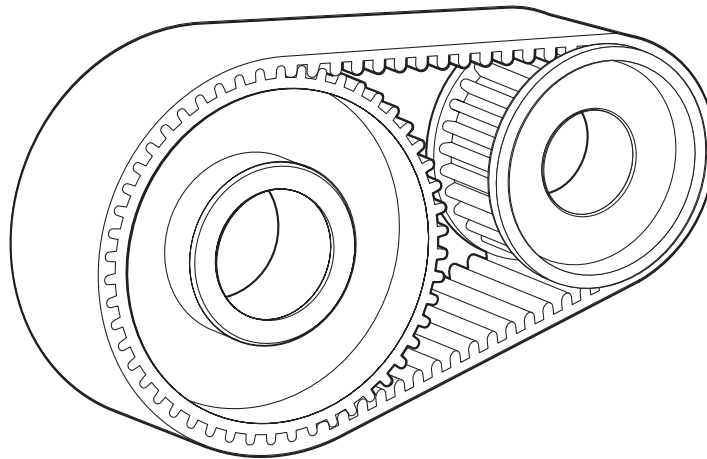

Fig. 5

(i) Name this mechanism.

..... [2]

(ii) Give **two** benefits of using this mechanism to move the plotter arm.

1.

..... [1]

2.

..... [1]

(iii) A pulley system could be used to move the plotter arm. Use sketches and notes to show a design for a suitable pulley system for this use.

[3]

(iv) Fig. 6 shows a pulley system to lift heavy objects in a workshop.

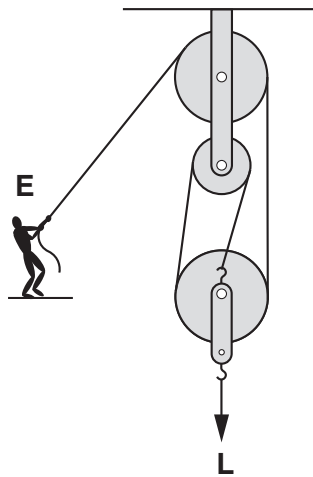

Fig. 6

Calculate the Mechanical Advantage of this system.

[3]

(v) Give **one** drawback to using pulley systems for lifting heavy objects.

.....

..... [2]

- 2 (a) Fig. 7 shows a circuit for an electronic timer to be used in a photographic darkroom.

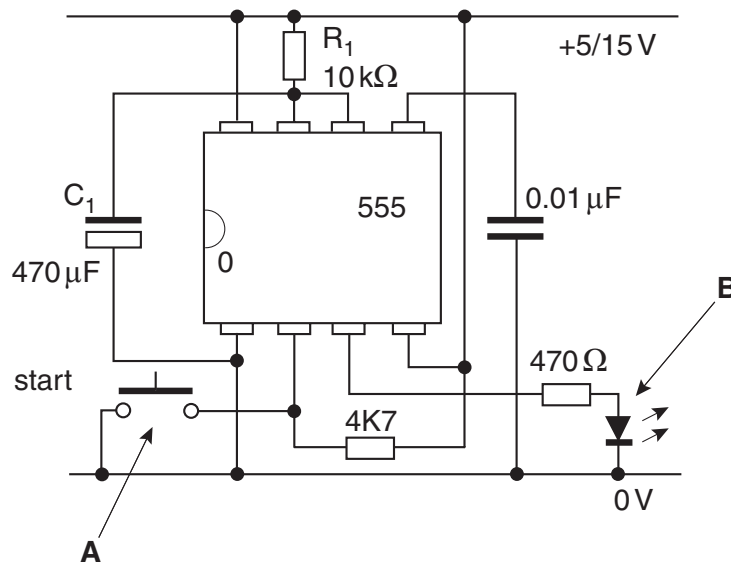

Fig. 7

- (i) Identify the component labelled **A**.

.....
 [1]

- (ii) Explain the purpose of component **B**.

.....

 [2]

- (iii) The value of the time delay is controlled by altering the values of C_1 and R_1 . If the value of C_1 is $470 \mu\text{F}$ and the value of R_1 is $10 \text{ k}\Omega$ calculate the time delay produced.

[3]

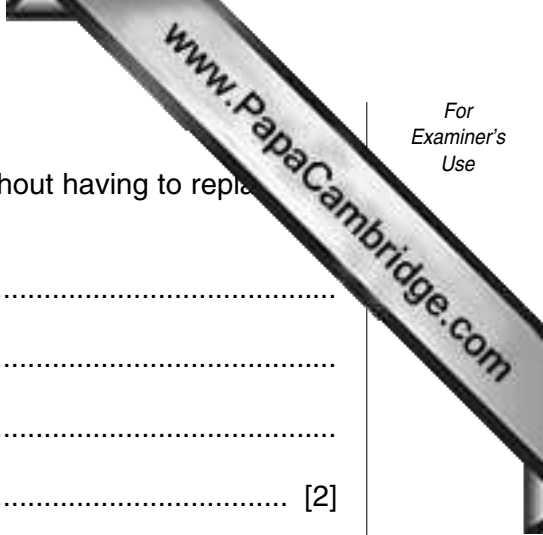

(iv) State **one** way that the time delay could be adjusted without having to replace component R_1 each time.

.....
.....
.....
..... [2]

(v) The timer circuit could be used to trigger an electromagnetic bell running off a separate circuit using a larger power supply. State how the two separate circuits could be interfaced to avoid current overload of the 555 IC.

.....
.....
.....
..... [2]

(b) The designer wishes to produce an electronic device to measure the temperature of the liquids stored in the darkroom.

(i) State the electronic component used to sense temperature.

.....
..... [1]

(ii) Draw the circuit symbol for this component.

[2]

(iii) Use sketches and notes to show how this component can be protected from short circuit when immersed in liquids.

[3]

(c) Fig. 8 shows an alarm that will sound if light falls on the LDR.

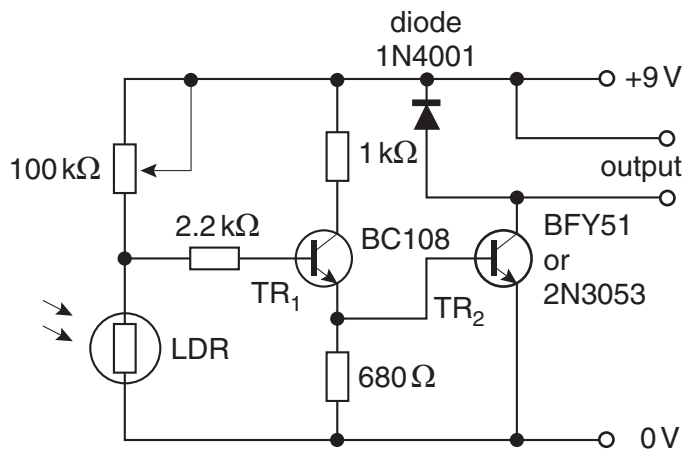

Fig. 8

(i) Explain why it is beneficial to have two transistors connected in this way.

.....

.....

.....

..... [3]

(ii) The second transistor TR₂ has a higher current rating than TR₁. Explain why this is the case.

.....

.....

.....

..... [2]

(iii) The connection of the LDR and the variable resistor is a form of potential divider. Explain the term potential divider.

.....

.....

.....

..... [2]

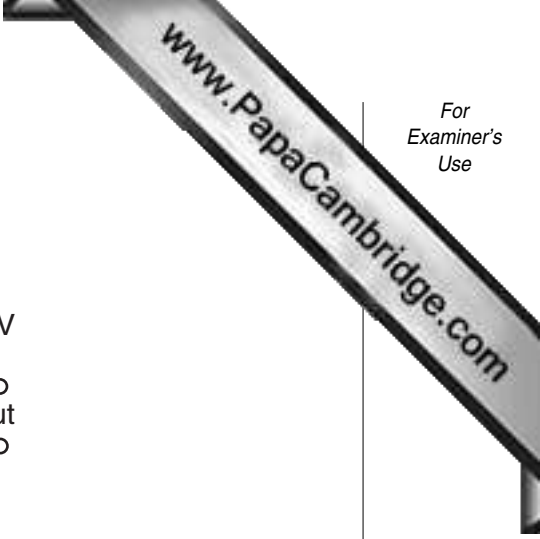

(iv) Fig. 9 shows a potential divider circuit.

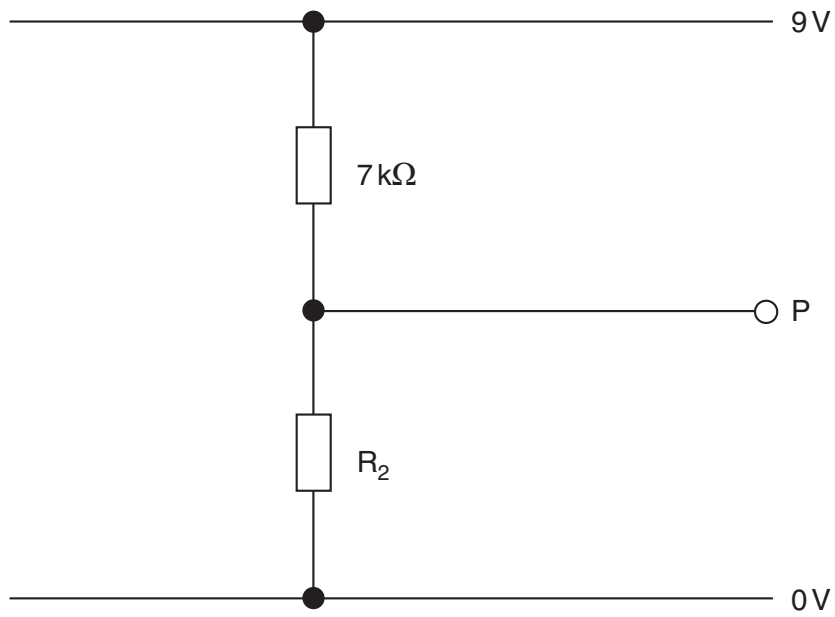

Fig. 9

Calculate the value of R_2 and the voltage at point P in the circuit.

[3]

(d) Fig. 10 shows a circuit symbol for a transistor.

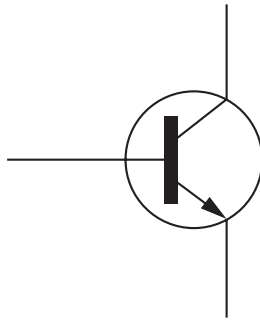

Fig. 10

(i) Label, **on Fig. 10**, each connection on the transistor. [3]

(ii) State **one** precaution that must be taken when soldering a transistor to avoid damage to the transistor.

.....

.....

.....

..... [1]

- 3 (a) Fig. 11 shows a shelf in a designer's studio.

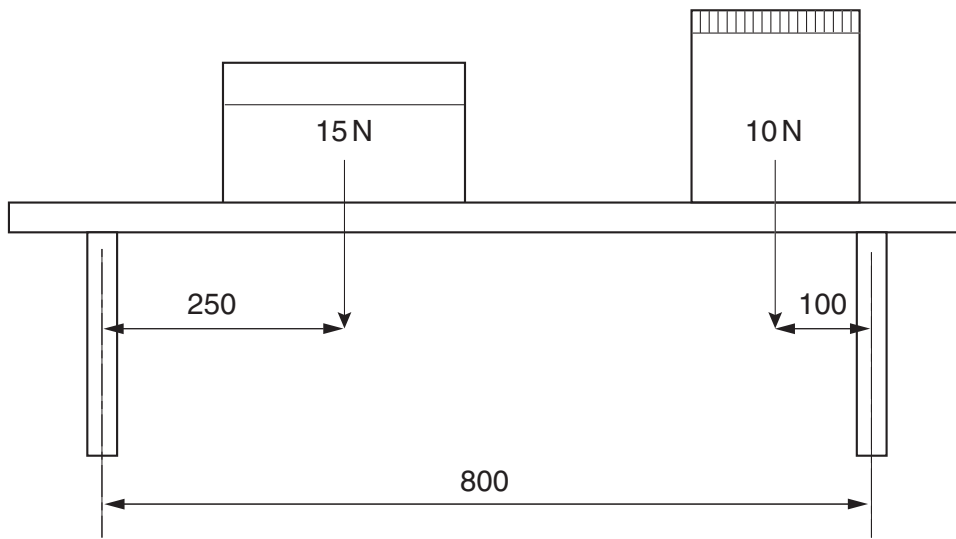

Fig. 11

- (i) Calculate the reactions at the supports for the shelf.

[4]

- (ii) Draw a Bending Moment diagram for the shelf.

[3]

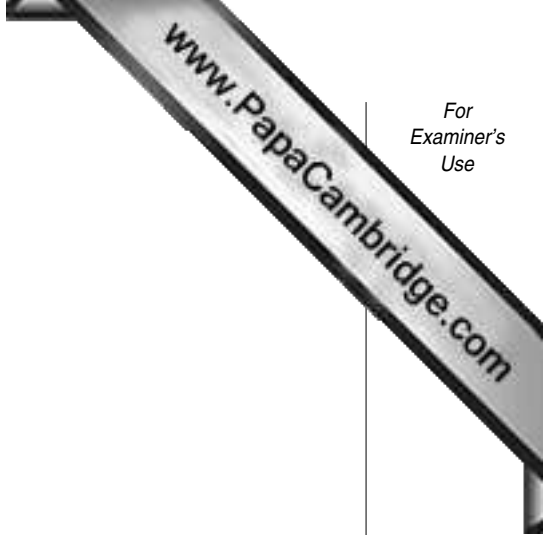

(iii) Draw a Shear Force diagram for the shelf.

[3]

(iv) Use sketches and notes to show **one** way of modifying the shelf to stop it from sagging in the middle.

[3]

(v) State **one** accurate method for measuring the deflection in the middle of the shelf.

.....

..... [2]

(b) Fig. 12 shows a diagram of an internal door.

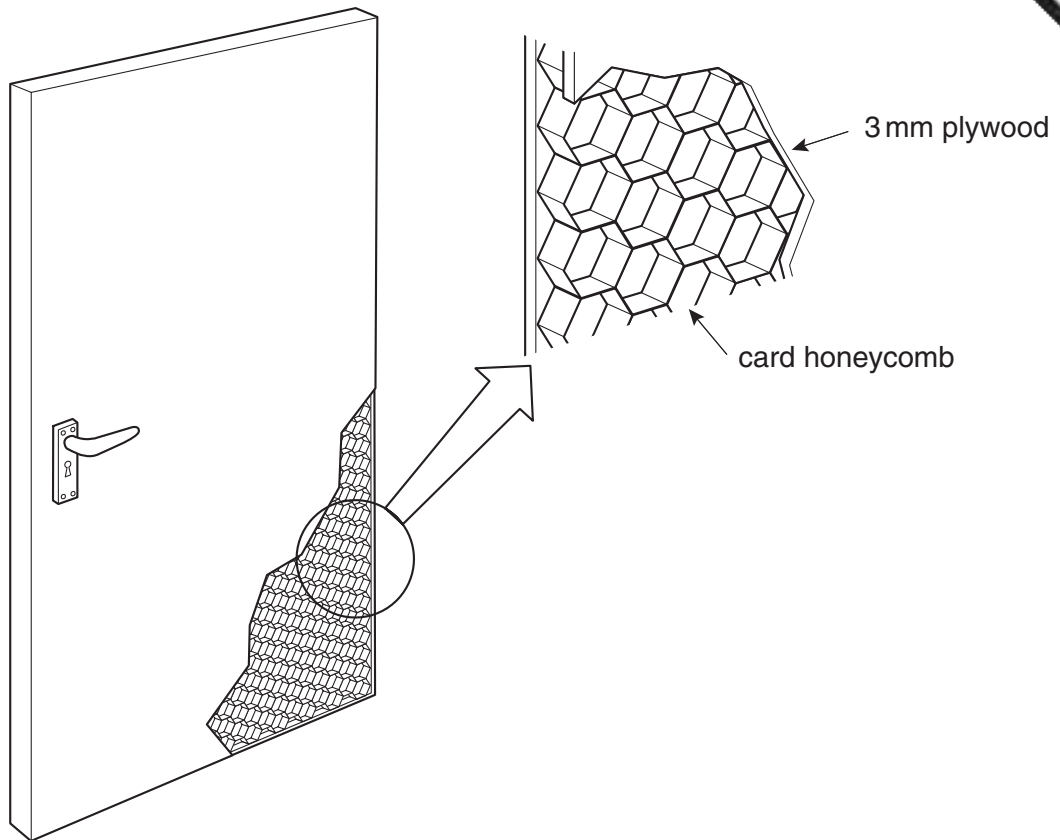

Fig. 12

(i) Give **two** benefits of this type of door construction.

.....
.....
.....
..... [3]

(ii) Explain why this construction would not be suitable for an outside door.

.....
..... [1]

(iii) Give another example of where this type of construction method is used.

.....
..... [1]

(c) Fig. 13 shows a set of free-standing shelves.

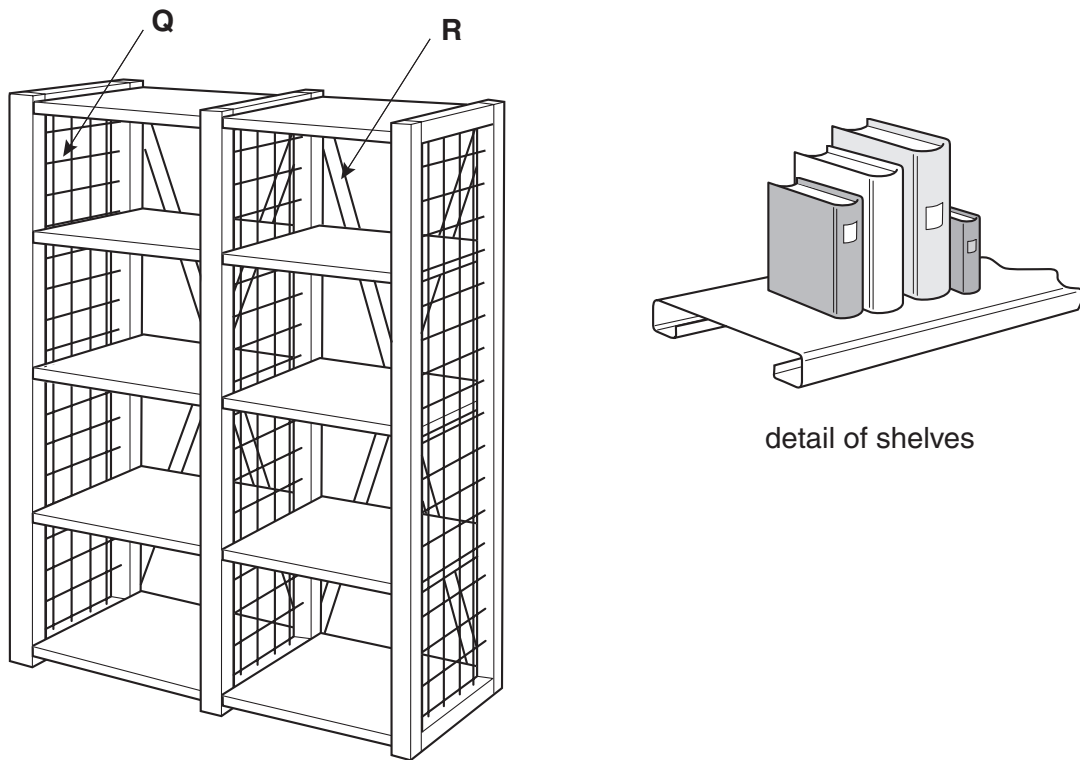

Fig. 13

(i) State the purpose of the parts labelled Q.

.....
.....
.....
..... [2]

(ii) State the purpose of the parts labelled R.

.....
.....
.....
..... [2]

(iii) Explain why the shelves are shaped as shown.

.....
.....
.....
..... [2]

(iv) Explain the reason why the bottom shelf does not rest on the floor.

.....
..... [2]

(v) Add labels to the diagram below to show the following:

- area in tension;
- area in compression.

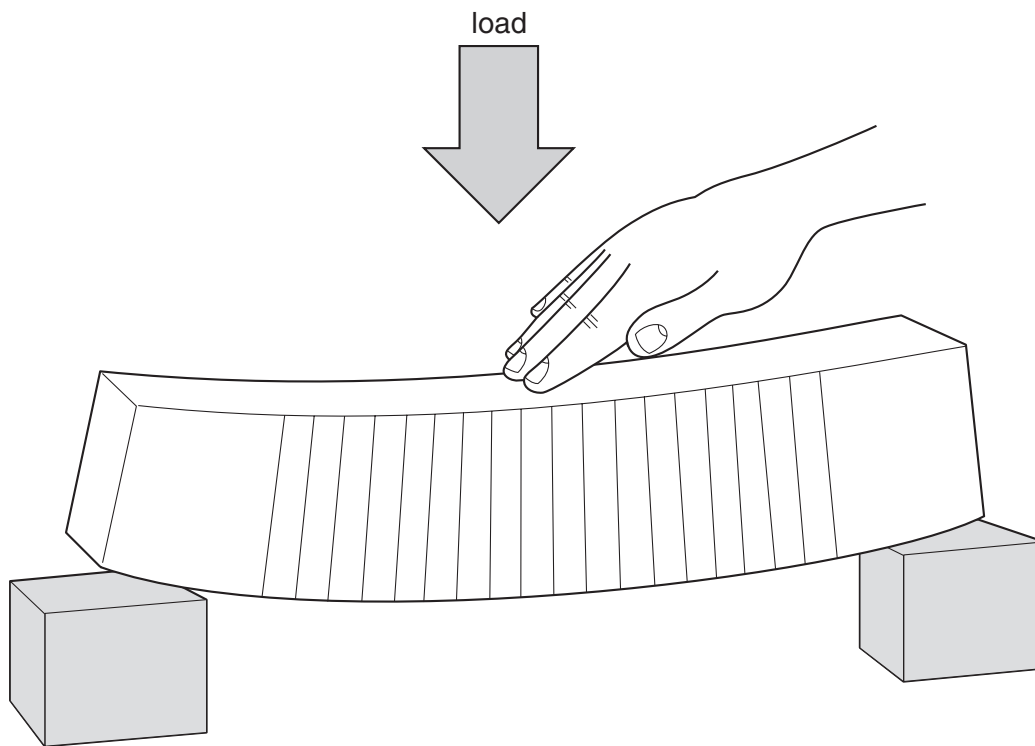

[2]

- 4 (a) A student decides to design a drawing board for use at home. The specification drawing board includes the following points:
- Must be adjustable for different angles of slope;
 - Must have a moveable rule that can slide up and down but also be locked into various positions;
 - Must be able to be folded up for easy storage when not in use.
- (i) Use sketches and notes to show your ideas for making the drawing board adjustable for different angles.

[5]

- (ii) Use sketches and notes to show how the rule could be made to move up and down and locked into various positions.

[5]

- (iii) Use sketches and notes to show how the board could be folded-up for storage.

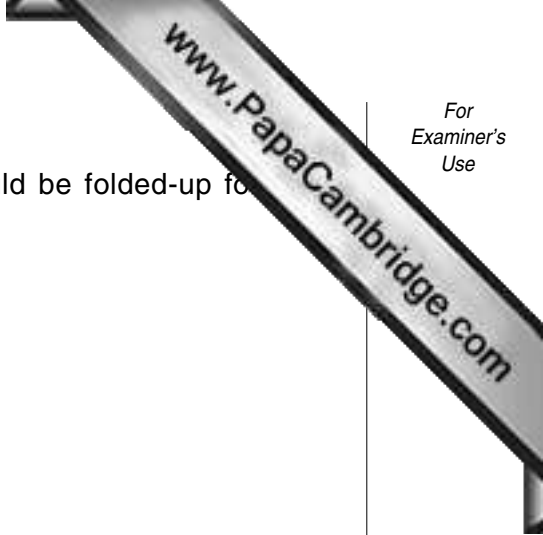

[3]

(b) Fig. 14 shows a linkage mechanism used to help artists enlarge and reduce copies of images.

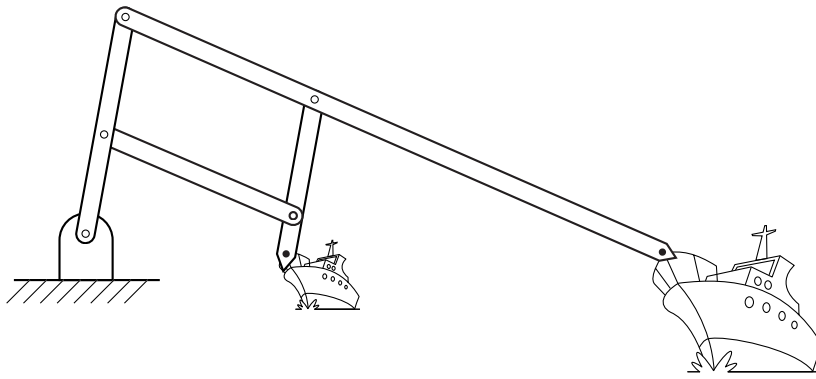

Fig. 14

(i) Explain how this mechanism can be used to enlarge a copy of an image.

.....

.....

.....

.....

.....

.....

..... [3]

(ii) Describe how this mechanism could be modelled from card.

.....

.....

.....

.....

.....

.....

..... [3]

(iii) This mechanism works on the principle of levers. Explain what a lever is.

.....

.....

.....

.....

..... [2]

(iv) Label the diagram below to show:

- fulcrum;
- load;
- effort.

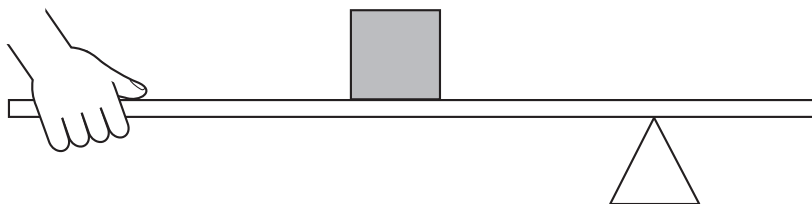

[3]

(v) Give **one** example of a class three lever.

.....

..... [1]

(c) Fig. 15 shows a light box to help a designer when tracing an image.

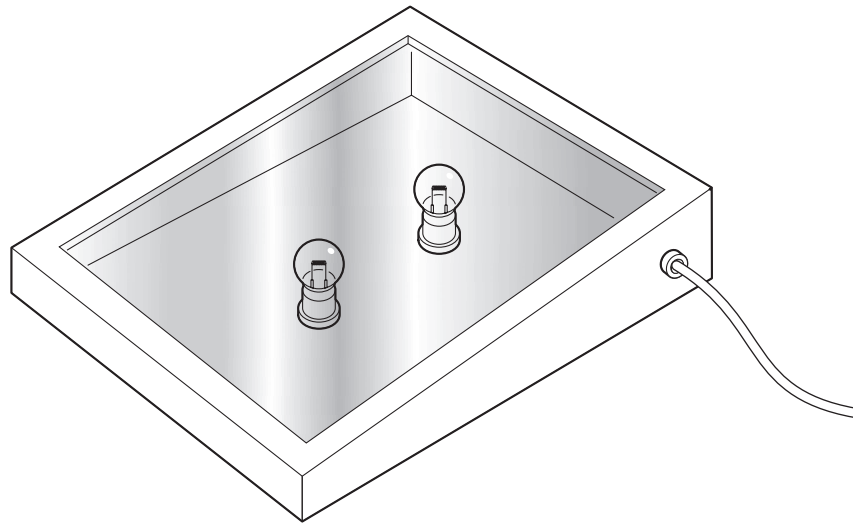

Fig. 15

- (i) There are two bulbs in the box. They can be switched on and off in the following combinations:
- both on;
 - both off;
 - one bulb on, one bulb off.

Show a circuit diagram of a suitable switching system to achieve the above operations.

[3]

- (ii) Describe **one** way of controlling the brightness of the bulbs if the designer wishes to vary the illumination levels.

.....

.....

.....

..... [2]

