

Centre Number	Candidate Number	Name
---------------	------------------	------

UNIVERSITY OF CAMBRIDGE INTERNATIONAL EXAMINATIONS
International General Certificate of Secondary Education

DESIGN AND TECHNOLOGY
DESIGN AND COMMUNICATION

0445/01
0446/01

Paper 1 Common Core

October/November 2006

1 hour 45 minutes

Additional Materials: A3 Drawing paper
Standard drawing equipment

To be taken together with the optional paper for which you have been entered in one session of 2 hours 45 minutes.

READ THESE INSTRUCTIONS FIRST

Write your name, centre number and candidate number in the spaces at the top of this page and on all separate answer paper used.

Write in dark blue or black pen.

You may use a soft pencil for any diagrams, graphs or rough working.

Do not use staples, paper clips, highlighters, glue or correction fluid.

Part A.

Answer **all** questions.

Write your answers in the spaces provided on the question paper.

Part B.

Answer **one** question.

Write or draw your answer on A3 drawing paper provided.

You may use a calculator.

At the end of the examination, fasten all your work securely together.

The number of marks is given in brackets [] at the end of each question or part question.

FOR EXAMINER'S USE

Part A	
Part B	
TOTAL	

Part A

Answer **all** questions in the spaces provided.

- 1 Fig. 1 shows an incomplete head and the handle of a toothbrush.

Complete the head by adding details of the bristles and render the handle to show that it is made from a shiny plastics material.

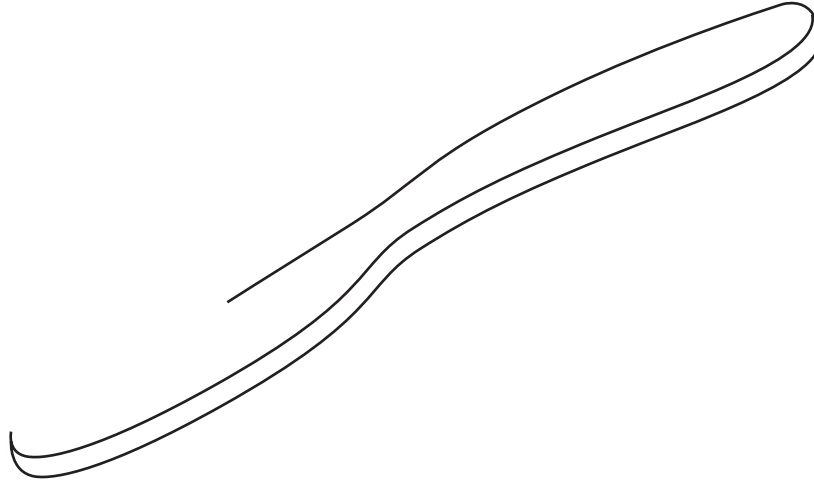

Fig. 1

[5]

- 2 List **four** specification points for a toy to be used by children aged two to four years.

- 1
- 2
- 3
- 4 [4]

3 Safety is an important consideration when working with some liquids and adhesives.

(a) State **two** safety hazards that could occur when working with liquids and adhesives.

- 1
- 2 [2]

(b) Give **two** safety precautions that should be taken to remove these hazards.

- 1
- 2 [2]

4 Solar power is an important source of energy.

(a) Give **two** benefits of solar power as a source of energy.

- 1
- 2 [2]

(b) Give **two** drawbacks of solar power as a source of energy.

- 1
- 2 [2]

5 Fig. 2 shows three marking out tools.

Name each tool and give a specific use for each, in the spaces provided.

(a)

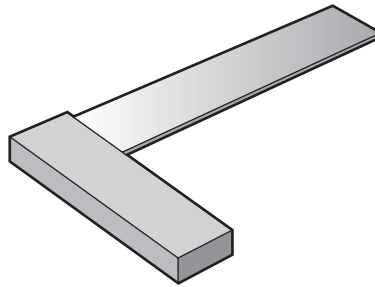

Name

Use [2]

(b)

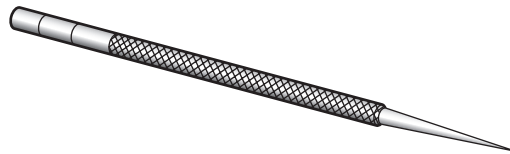

Name

Use [2]

(c)

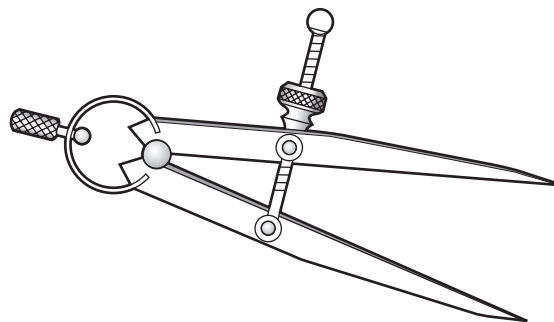

Name

Use [2]

Fig. 2

5

6 Fig. 3 shows a child's swing in use.

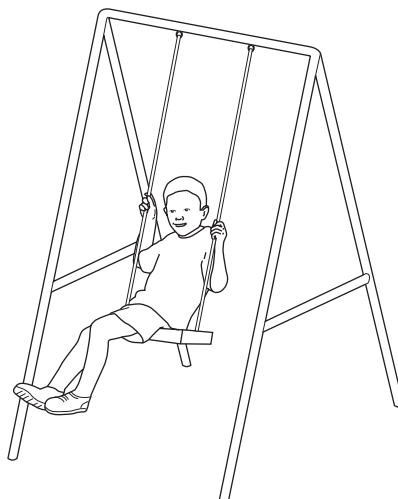

Fig. 3

(a) Add labels to Fig. 3 to show **one** part in tension and **one** part in compression. [2]

(b) Complete the following statement.

A strut can only be made from a material but a tie
can be made from a rigid or a material [2]

7 Fig. 4 shows a cutaway section through a toy car.

Draw on Fig. 4 to show a mechanism that will make the driver move up and down as the toy car is pushed along the floor.

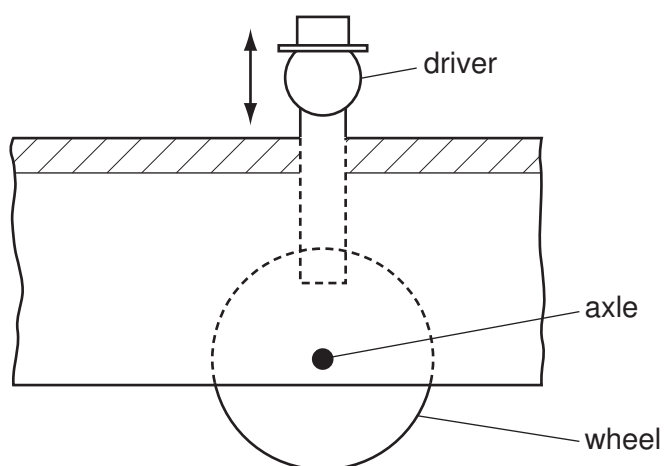
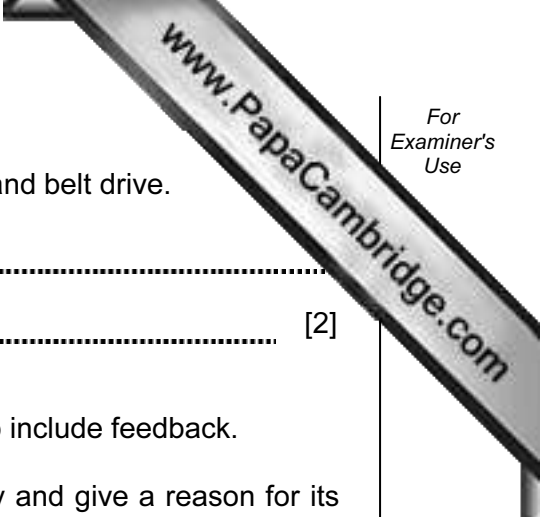

Fig. 4

[3]



8 Give **two** advantages of a sprocket and chain drive over a pulley and belt drive.

- 1
- 2 [2]

9 In addition to input, process and output some control systems also include feedback.

(a) Identify a device that requires feedback to operate effectively and give a reason for its inclusion.

Device

Reason [3]

(b) Name the type of output sensor that could be used in this control system.

..... [1]

10 Use **two** examples to explain how ergonomics might be considered in the design of an electric bench drill used in school workshops.

.....

.....

.....

.....

.....

..... [4]

Part B

Answer **one** question using the A3 paper provided.

11



Brushes, tools and other pieces of equipment often become lost or misplaced when decorating at home.

A portable storage system for all of these items would be very useful.

- (a) List **four** points about the function of such a storage system that you consider to be important. [4]
- (b) Describe, with notes and sketches, **two** ways of locating and holding items in any storage system. [4]
- (c) Develop and sketch ideas for the storage system. [15]
- (d) Evaluate your ideas and justify why you have chosen one idea to develop more fully. [8]
- (e) Draw, using a method of your own choice, a full solution to your problem. [18]
- (f) Suggest suitable materials for your solution and give reasons for your choice. [4]
- (g) Outline a method used to manufacture **one** part of your solution in the school workshop. [7]

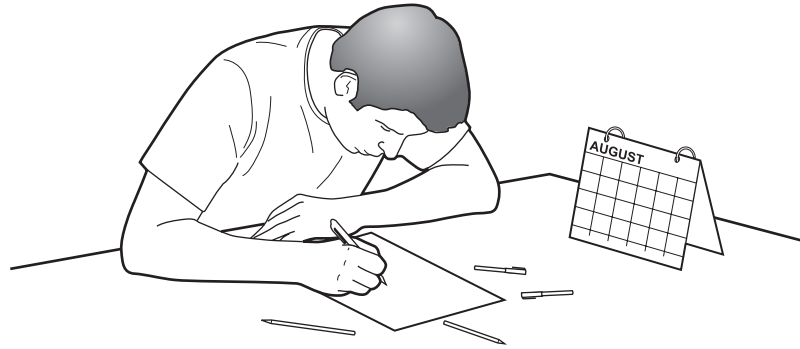

A supplier of stationery equipment called OFFICE has asked you to design a desk tidy that will advertise the company and be given away to potential customers at an exhibition.

The desk tidy must fold flat, be able to display each month of the calendar as required and hold pens and pencils.

- (a) List **four** points about the design of such a desk tidy that you consider to be important. [4]
- (b) List **two** materials and **two** joining methods that could be used to produce the desk tidy. [4]
- (c) Develop and sketch ideas for the desk tidy. [15]
- (d) Evaluate your ideas and justify why you have chosen one idea to develop more fully. [8]
- (e) Draw, using a method of your own choice, a full solution to your problem. [18]
- (f) Describe **two** benefits of using CAD in the design of such an item. [4]
- (g) Use notes and sketches to describe a practical gift that the company might give away. [7]

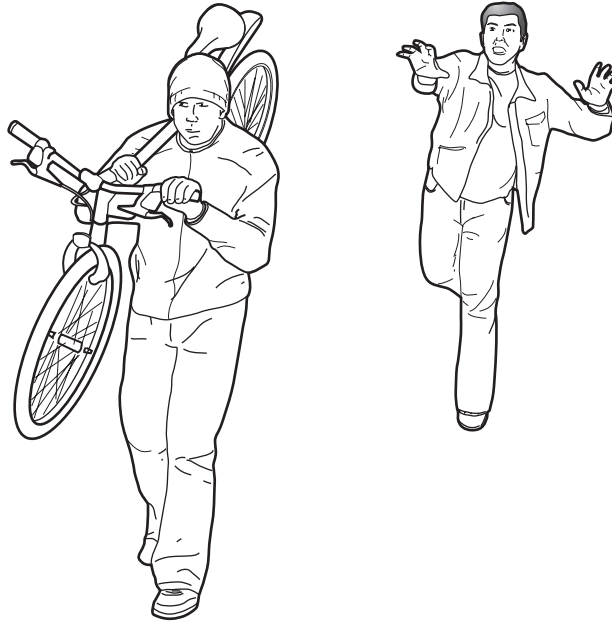

Although bicycles can be partially secured by locking a chain around a wheel it is still possible for someone to carry the bicycle away.

A method of securing pupils' bicycles so that they cannot be carried away would be a very popular addition at your school.

- (a) List **four** points about the function of such a system that you consider to be important. [4]
- (b) Use notes and sketches to describe **two** different locking devices. [4]
- (c) Develop and sketch ideas for the security system. [15]
- (d) Evaluate your ideas and justify why you have chosen one idea to develop more fully. [8]
- (e) Draw, using a method of your own choice, a full solution to your problem. [18]
- (f) Suggest suitable materials for your solution and give reasons for your choice. [4]
- (g) Outline a method used to manufacture **one** part of your solution in the school workshop. [7]

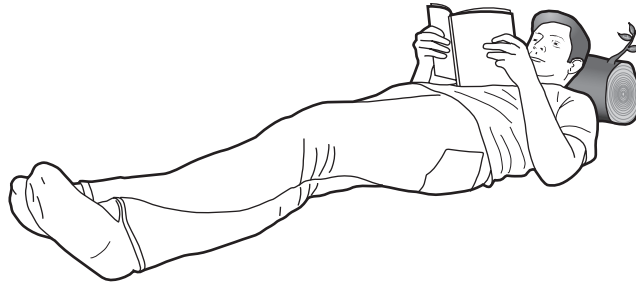

Many people enjoy relaxing with a book when they are on holiday. However, it is sometimes difficult to find a comfortable position in which to do so.

Some form of portable headrest that could be carried easily would be very useful.

- (a) List **four** points about the function of such a headrest that you consider to be important. [4]
- (b) List **four** other items in everyday use that are designed to be portable. [4]
- (c) Develop and sketch ideas for the headrest. [15]
- (d) Evaluate your ideas and justify why you have chosen one idea to develop more fully. [8]
- (e) Draw, using a method of your choice, a full solution to your problem. [18]
- (f) Suggest suitable materials for your solution and give reasons for your choice. [4]
- (g) Outline a method used to manufacture **one** part of your solution in the school workshop. [7]

