



UNIVERSITY OF CAMBRIDGE INTERNATIONAL EXAMINATIONS
International General Certificate of Secondary Education

CANDIDATE NAME

CENTRE NUMBER

CANDIDATE NUMBER

* 5 5 6 1 0 6 1 7 2 3 *

DESIGN AND TECHNOLOGY **0445/03**
Paper 3 Resistant Materials **October/November 2007**
1 hour

Candidates answer on the Question Paper.
No Additional Materials are required.
To be taken together with Paper 1 in one session of 2 hours 15 minutes.

READ THESE INSTRUCTIONS FIRST

Write your Centre number, candidate number and name on all the work you hand in.
Write in dark blue or black pen.
You may use a soft pencil for any diagrams graphs or rough working.
Do not use staples, paper clips, highlighters, glue or correction fluid.
DO NOT WRITE IN ANY BARCODES.

Section A
Answer **all** questions.

Section B
Answer **one** question.

You may use a calculator.

At the end of the examination, fasten all your work securely together.
The number of marks is given in brackets [] at the end of each question or part question.

For Examiner's Use	
1	
2	
Total	

This document consists of **15** printed pages and **1** blank page.

Section A

Answer all questions in this section.

1

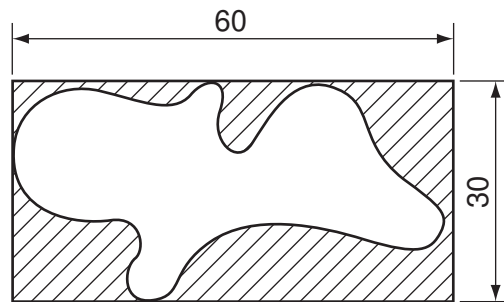

Name the type of saw used to cut the curved shape shown above when made from:

(a) 1 mm thick copper; [1]

(b) 4 mm thick plywood. [1]

2 Describe a specific use for the following adhesives:

(a) contact / impact; [1]

(b) epoxy resin. [1]

3 Complete the sketch below to show a lap joint.

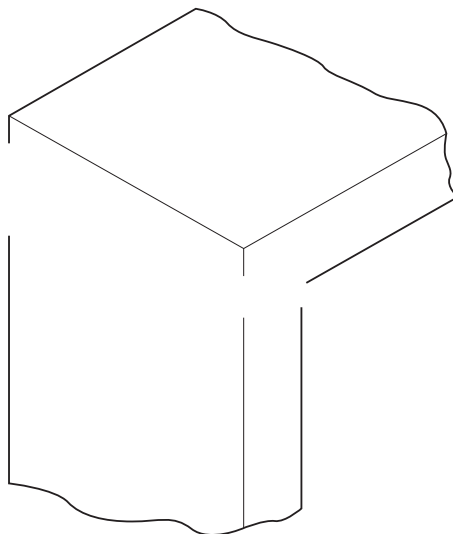

[2]

4 Complete the table below by naming a suitable specific plastic for each product.

Product	Specific plastic
Packaging and insulation	
Electrical fittings	
Gear wheels	
Buckets and bowls	

[4]

5 Describe **two** methods of checking the squareness of the frame shown in Fig.1.

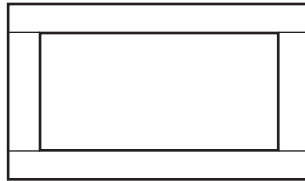
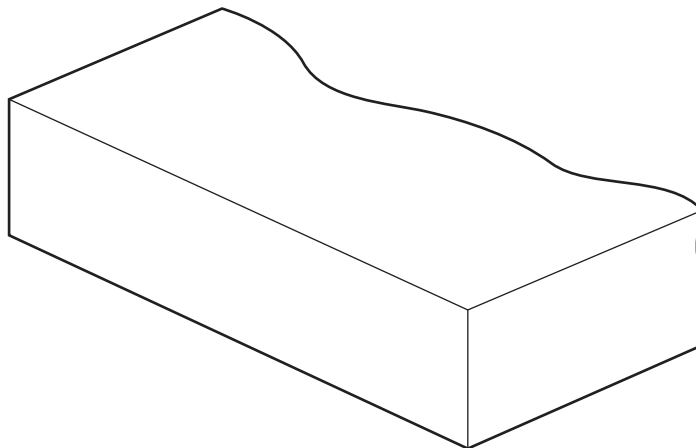

Fig. 1

1 [1]

2 [1]

6 Complete the sketch below to show the construction of plywood.



[2]

7 Fig.2 shows a round bar of metal.

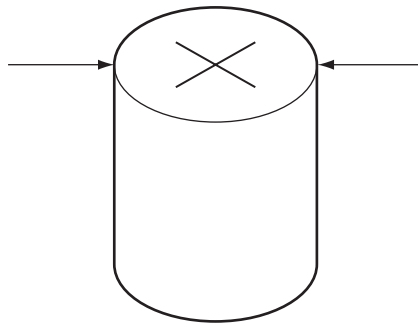

Fig. 2

Name the tool used to:

(a) measure the outside diameter of the round bar;

..... [1]

(b) find the centre of the round bar.

..... [1]

8 Knurled surfaces are produced on tools such as scribers and centre punches.

(a) Explain the purpose of a knurled surface.

..... [1]

(b) Describe how the knurled surface could be produced.

.....
..... [2]

9 Name **two** marking out tools used to mark out the joint shown below.

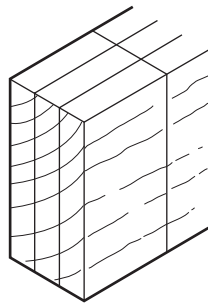

solid wood

1 [1]

2 [1]

10 Fig. 3 shows three boards that have been glued together.

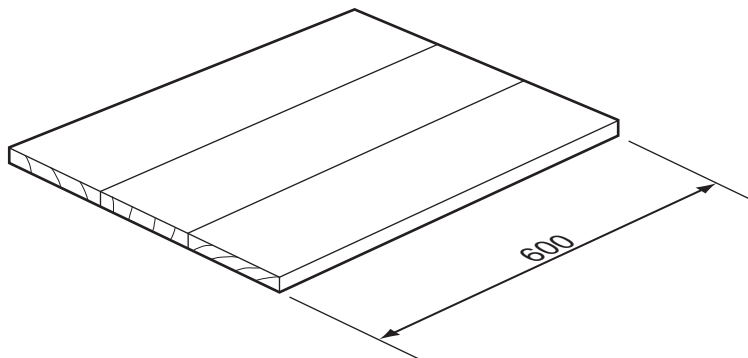

Fig. 3

(a) Name the cramps used to hold the boards together when glued.

.....cramps [1]

(b) Add to Fig. 3 to show how **three** cramps would be used to hold the boards together. [3]

Section B

Answer **one** question in this section.

11 Fig. 4 shows views of a bedside cabinet made from manufactured board.

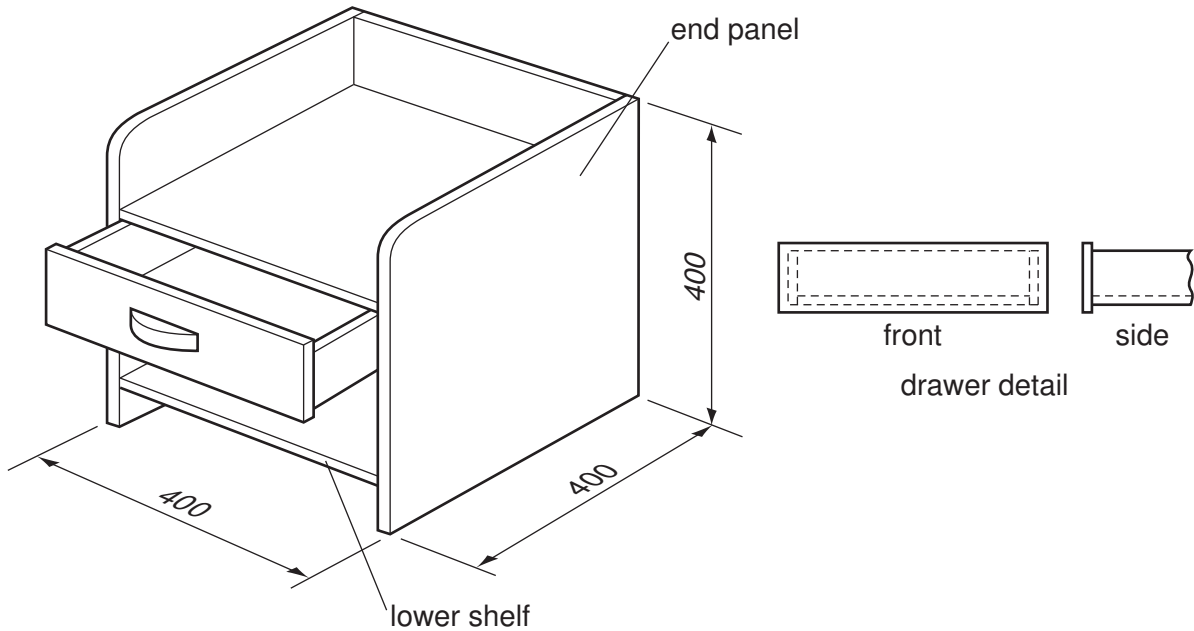

Fig. 4

(a) (i) Name a suitable manufactured board for the bedside cabinet.

..... [1]

(ii) Give **two** reasons why a manufactured board would be more suitable than solid wood for the bedside cabinet.

1 [1]

2 [1]

(iii) Suggest a suitable thickness for the end panel.

..... [1]

(b) Fig. 5 shows the two end panels and the two shelves marked out on a length of manufactured board.

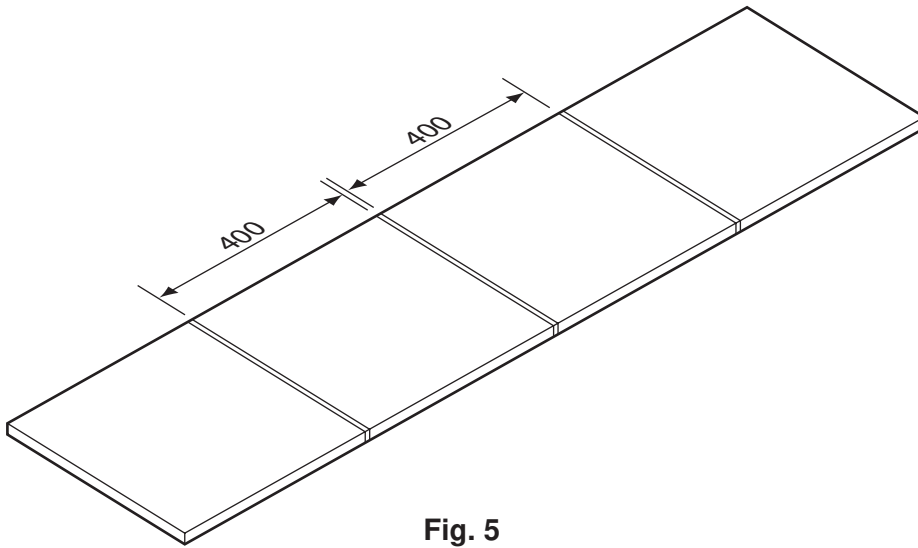

Fig. 5

(i) Name **two** marking out tools used to mark out the end panels and shelves.

1 [1]

2 [1]

(ii) Explain why there is a space between each of the 400 mm lengths.

.....
..... [2]

(iii) Name a saw that could be used to saw the end panels and shelves from the length of manufactured board.

..... [1]

(iv) Some manufactured boards splinter when they are sawn.

Describe how this problem may be overcome.

.....
..... [2]

(c) Use notes and sketches to show how the lower shelf and end panel:

(i) could be joined together temporarily, using knock-down [K-D] fittings;

[4]

(ii) could be joined together permanently.

[4]

(d) Use notes and sketches to show how the drawer could be located inside the cabinet without adding another shelf.

Include details of all materials, fittings and fixings you would use.

[6]

12 Fig. 6 shows a moneybox made from plastic.

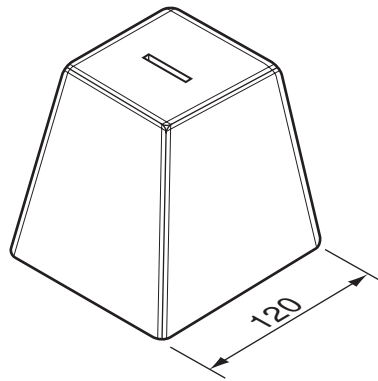

Fig. 6

(a) (i) The moneybox will be produced by vacuum forming.

Name a suitable plastic for the moneybox.

..... [1]

(ii) Name **two** other household products that are produced by vacuum forming.

1 [1]

2 [1]

(b) Fig. 7 shows the former used to make the moneybox attached to a board ready to vacuum form.

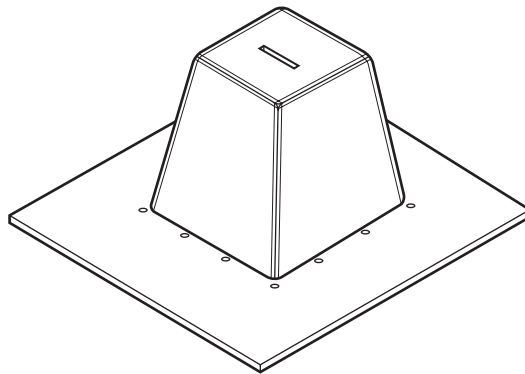

Fig. 7

State **three** features of the former that will ensure that the moneybox can be vacuum formed successfully.

1 [1]

2 [1]

3 [1]

(c) Fig. 8 shows a wooden block from which the former of the moneybox will be made.

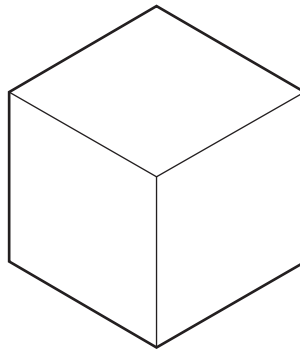
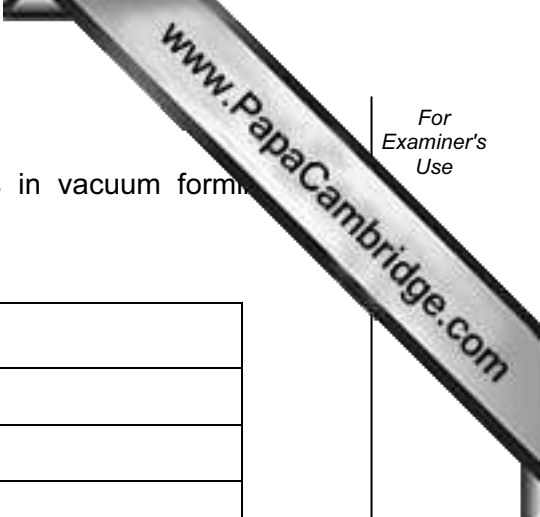

Fig. 8

Use notes and sketches to show how the former could be made from the wooden block. Include details of the following stages:

- marking out;
- holding the block and sawing it to shape;
- smoothing the sides and rounding the corners.



(d) Complete the table below by giving details of the stages in vacuum forming moneybox.

Vacuum forming stages
Position former on platen of vacuum forming machine
Remove plastic from machine

[5]

(e) Use notes and sketches to show how a base could be fitted to the moneybox. The base must be capable of removal. The design of the moneybox may be modified to take the base.

[6]

(f) The moneybox in Fig. 6 could be made from wood.

Give **one** advantage and **one** disadvantage of using vacuum formed plastic for the moneybox rather than wood.

Advantage [1]

Disadvantage [1]

13 Fig. 9 shows a garden lantern.

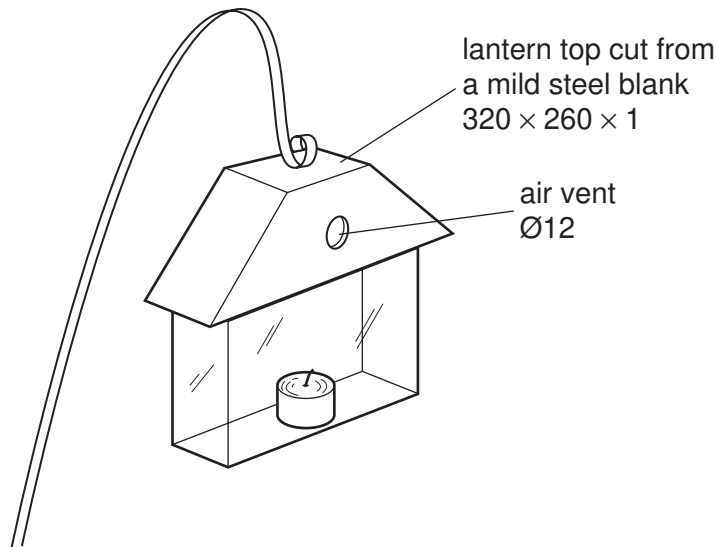

Fig. 9

(a) Fig. 10 shows the incomplete development [net] of the top of the lantern.

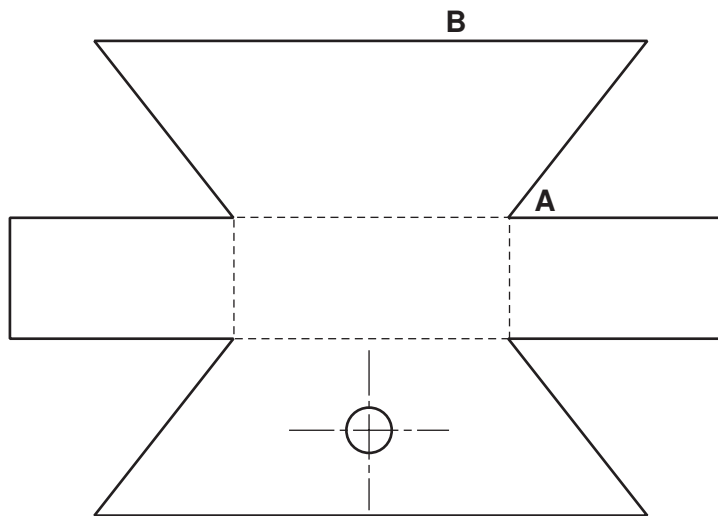

Fig. 10

(i) Name **three** marking out tools used to mark out the development [net] on mild steel sheet.

- 1 [1]
- 2 [1]
- 3 [1]

www.PapaCambridge.com

(ii) Describe how a template could be used to assist manufacture of twenty lanterns.

.....
..... [2]

(iii) Tabs are to be added to the development [net] to allow the top to be joined together.

Complete the development [net] in Fig. 10 by adding the tabs. [4]

(b) Name **two** tools used to cut out the 1 mm thick mild steel shape.

1 [1]

2 [1]

(c) (i) Name the type of file that would be used to file inside corner **A** in Fig. 10.

..... [1]

(ii) Use notes and sketches to show how the mild steel sheet could be held so that edge **B** in Fig. 10 could be filed flat.

(d) The hole for the air vent in Fig. 9 will be drilled using a drilling machine.

Describe **one** possible danger when drilling thin sheet material.

.....
..... [2]

(e) The mild steel top of the lantern will be painted.

Give **two** reasons why the top will need to be painted.

1 [1]
2 [1]

- (f) Fig. 11 shows the lantern top separated from its base.

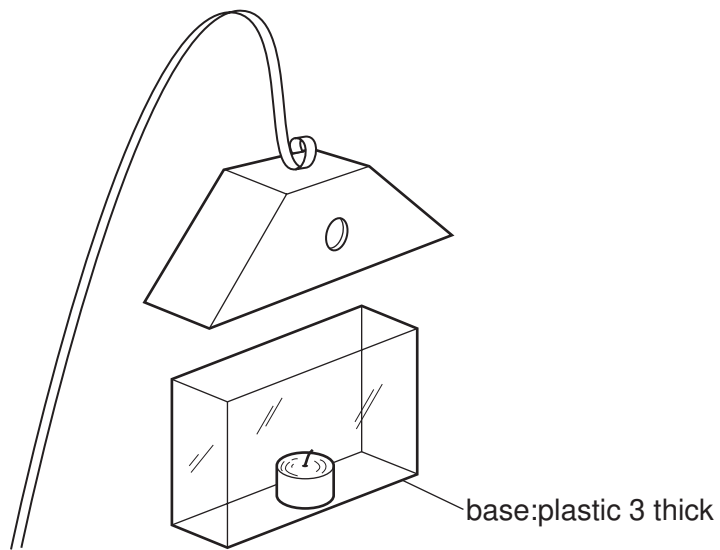

Fig. 11

Use notes and sketches to show how the top and the base could be fixed together. Modifications to the top and/or the base may be carried out to enable the parts to be fixed together.

Copyright Acknowledgements:

Permission to reproduce items where third-party owned material protected by copyright is included has been sought and cleared where possible. Every reasonable effort has been made by the publisher (UCLES) to trace copyright holders, but if any items requiring clearance have unwittingly been included, the publisher will be pleased to make amends at the earliest possible opportunity.

University of Cambridge International Examinations is part of the Cambridge Assessment Group. Cambridge Assessment is the brand name of University of