



UNIVERSITY OF CAMBRIDGE INTERNATIONAL EXAMINATIONS  
International General Certificate of Secondary Education

CANDIDATE  
NAME

CENTRE  
NUMBER

--	--	--	--	--

CANDIDATE  
NUMBER

--	--	--	--

\* 6 8 5 6 1 0 1 1 6 9 \*

**DESIGN AND TECHNOLOGY**

**0445/04**

Paper 4 Systems and Control

**October/November 2008**

**1 hour**

Candidates answer on the Question Paper.

No Additional Materials are required.

**To be taken together with Paper 1 in one session of 2 hours and 15 minutes.**

**READ THESE INSTRUCTIONS FIRST**

Write your Centre number, candidate number and name on all the work you hand in.

Write in dark blue or black pen.

You may use a soft pencil for any diagrams or graphs.

Do not use staples, paper clips, highlighters, glue or correction fluid.

**DO NOT WRITE IN ANY BARCODES.**

You may use a calculator

**Section A**

Answer **all** questions.

**Section B**

Answer **one** question.

At the end of the examination, fasten all your work securely together.

The number of marks is given in brackets [ ] at the end of each question or part question.

For Examiner's Use	
Section A	
Section B	
<b>Total</b>	

This document consists of an **15** printed pages and **1** blank page.



Section A

Answer **all** questions in this section.

1 (a) Complete the statement below.

A thermistor senses changes in ..... [1]

(b) Give **one** example of a use for a thermistor.

..... [1]

2 Name **three** types of motion.

1 .....

2 .....

3 ..... [3]

3 Sketch and label **one** example of a third-order lever.

[3]

4 Complete the block diagram below to show the energy conversions that take place when a battery-powered torch is used.

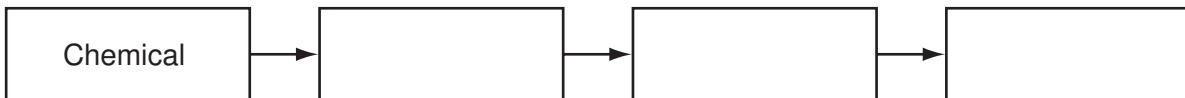

[3]

5 A rack and pinion is a type of gear system.

(a) Give **one** example of the use of a rack and pinion gear system.

..... [1]

(b) Describe the motion conversion that takes place when a rack and pinion gear system operates.

.....  
.....  
..... [3]

6 (a) Give **one** example of the use of a reed switch.

..... [1]

(b) Sketch and label a reed switch.

[3]

7 Explain the term 'bread-boarding' in electronics.

.....  
.....  
..... [2]

8 Complete the statement below.

A moment of force is defined as Force  $\times$  ..... [1]

9 (a) Name the type of force that twists a member.

..... [1]

(b) Give **one** example of where a twisting force can be found.

..... [1]

10 Complete the statement below.

Flat, toothed, round and vee are all types of ..... [1]

Section B

Answer **one** question from this section.

11 Fig. 1 shows a design for an automated pumping device.

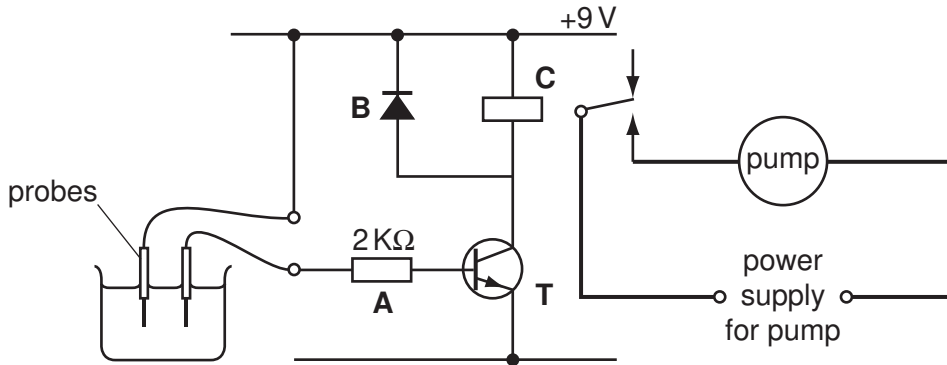

Fig. 1

(a) Describe how this circuit works when water reaches the probes.

.....

.....

.....

.....

.....

.....

.....

..... [3]

(b) Explain the purpose of component C.

.....

.....

.....

..... [3]

(c) Explain the purpose of component B.

.....

.....

..... [2]

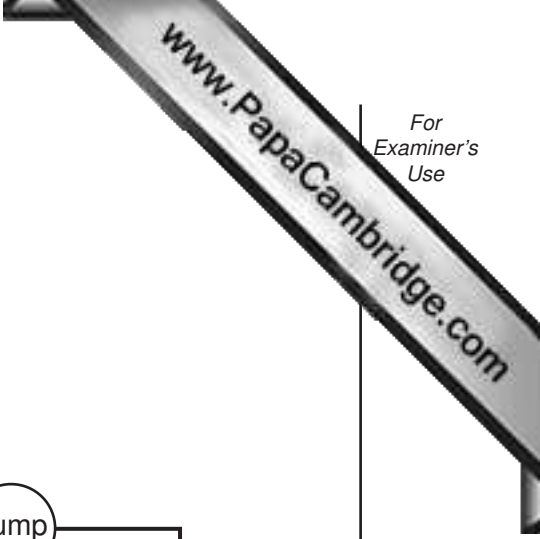

(d) Explain the purpose of component **A**.

.....  
 .....  
 ..... [3]

(e) The circuit is found to be lacking in sensitivity.

Explain how the circuit could be made more sensitive.

.....  
 .....  
 ..... [2]

(f) Fig. 2 shows a potential divider used to control a transistor.

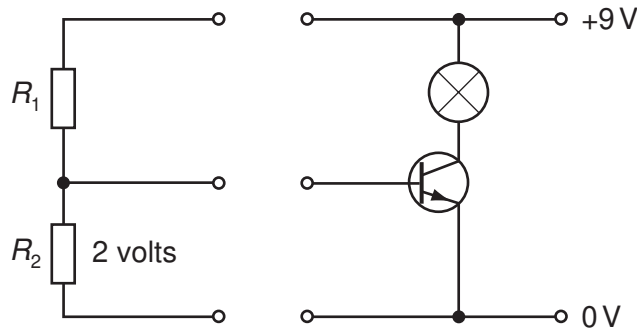

**Fig. 2**

Given that the voltage across  $R_2$  needs to be 2 V for the transistor to work, and that the current flowing is 1 mA, calculate the value of  $R_1$ .

[3]

**(g) (i)** State how the value is shown on a resistor.

.....

**(ii)** Resistors have a tolerance value.

Explain what is meant by tolerance value.

.....

.....

..... [2]

**(h)** Logic gates can be used to control electrical systems.

A NOT gate is used with an LDR to control a security light that comes on when daylight falls below a set level.

**(i)** Complete the truth table for a NOT gate.

Input	Output

[3]

**(ii)** Draw the circuit symbol for a NOT gate.

[3]

12 The camera tripod shown in Fig. 3 uses a number of mechanisms.

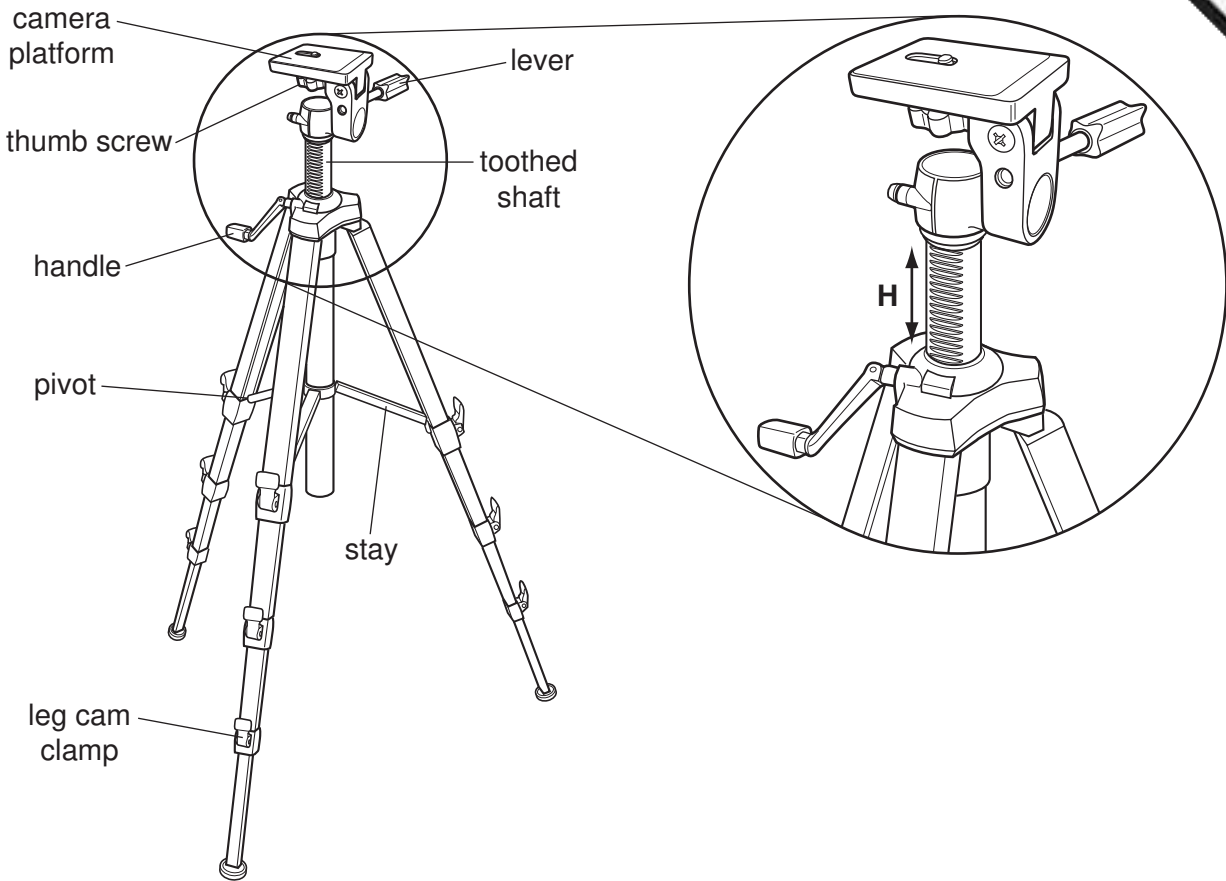

Fig. 3

(a) Explain the shape of the handle in terms of mechanical advantage (MA).

.....  
 .....  
 ..... [2]

(b) The leg clamp uses an eccentric cam.

Use sketches and notes to show how an eccentric cam is used as a clamping device.



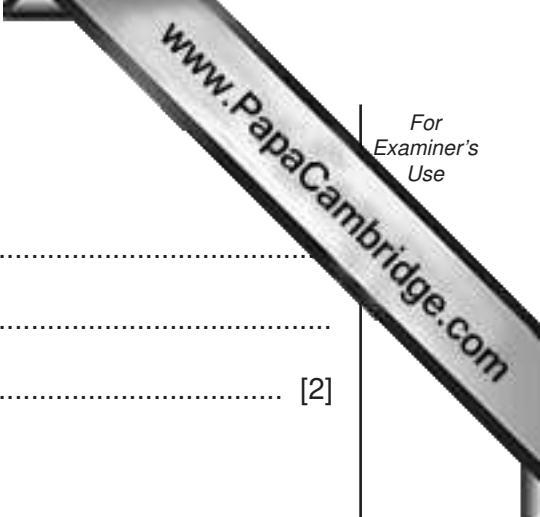

(c) Explain the purpose of the stay.

.....  
.....  
..... [2]

(d) The thumb screw is used to secure the camera in position.

Describe the motion conversions that take place when the thumb screw is used.

.....  
.....  
..... [2]

(e) Use sketches and notes to show how turning the handle adjusts the height **H**.

[3]

(f) The pivot is subjected to shear force.

Use sketches and notes to show what is meant by shear force.

[2]

(g) (i) Explain how the lever makes it easier for the camera to be positioned.

.....  
.....  
..... [2]

(ii) Fig. 4 shows a lever system.

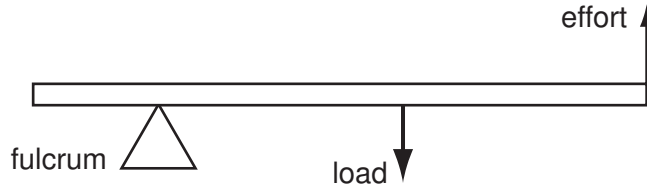

Fig. 4

Identify the order of lever shown in Fig. 4.

..... [1]

(iii) Use sketches and notes to show how a lever can be used to magnify a small movement.

[3]

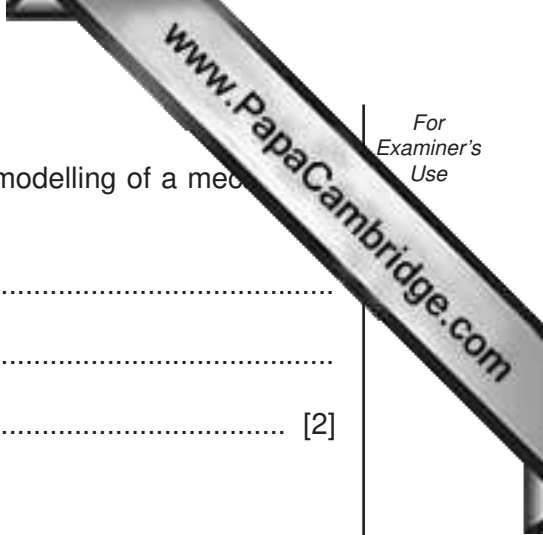

(h) (i) Describe **one** example of a construction kit used in the modelling of a mechanical system.

.....  
.....  
..... [2]

(ii) Give **one** other way of modelling a mechanical system.

..... [1]

(iii) Explain the purpose of modelling a mechanical system prior to making it from resistant materials.

.....  
.....  
..... [2]

13 Fig. 5 shows a simple experiment into loading of a beam.

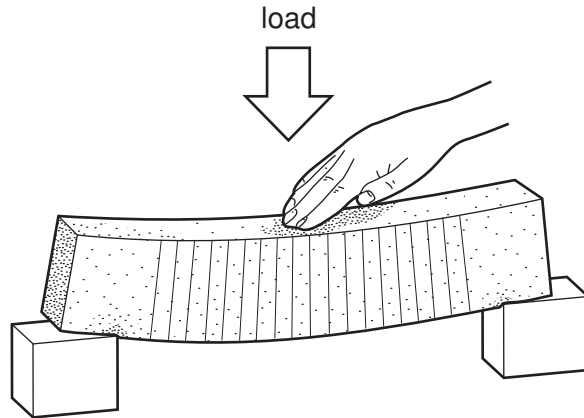

Fig. 5

- (a) Add labels to Fig. 5 to show the areas of tension and compression on the beam. [2]
- (b) If the load on the beam is 100 N and the distance between the supports is 300 mm, determine the reactions at each support.

[2]

(c) Structural materials are reinforced to improve their capability to carry loads.

Complete the table below to show various reinforcement methods and their uses.

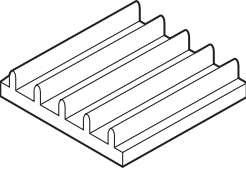
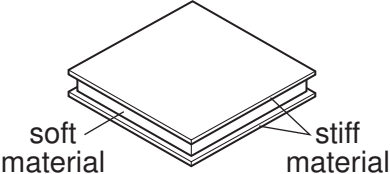
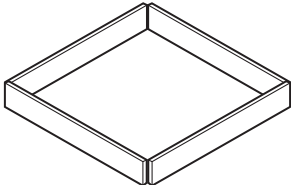
Name	Diagram	Use
Ribs		[1]
[1]		Display board
Triangulation	[1]	[1]
Folding		[1]

(d) The cross-sectional shape of materials is an important feature of structural design.

Look at the diagram below and explain why the beam is shaped in this way.

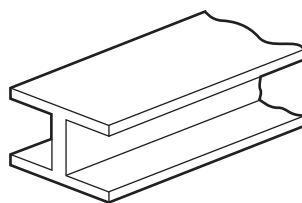

.....  
 .....  
 ..... [3]

(e) Fig. 6 shows a graph of stress against strain for mild steel.

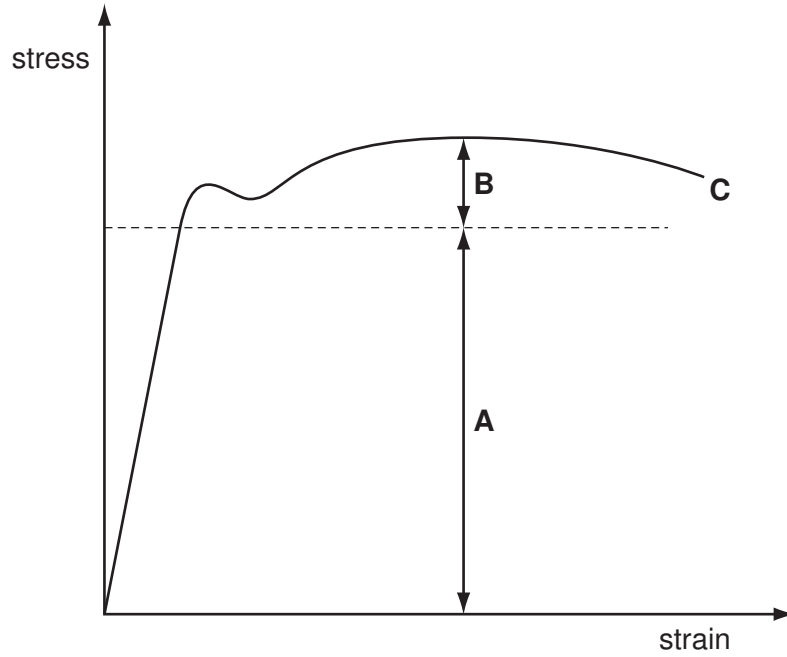

Fig. 6

(i) Explain how the material behaves in region A.

.....  
.....  
..... [2]

(ii) Explain how the material behaves in region B.

.....  
.....  
..... [2]

(iii) State what happens to the material at point C.

..... [1]

(f) Fig. 7 shows a test sample.

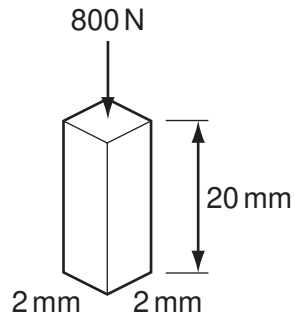

**Fig. 7**

(i) Calculate the stress on this sample.

[3]

(ii) Explain the effect on the stress if the sample was increased in area to  $4\text{ mm} \times 4\text{ mm}$ .

.....

..... [2]

(iii) If the sample was subjected to a compressive load and its length shortened by 0.04 mm, calculate the strain on the sample.

[3]

