

Section A

Answer **all** questions in this section.

A1 An incomplete direction sign for 'ARRIVALS' at an airport is drawn to the right.

Complete the direction sign by adding the **four** remaining letters.

All the letters must be the same height, spacing and style as those given. [6]



The sketch below shows details of an aircraft warning symbol for ground traffic at an airport. The symbol appears inside an octagonal sign.

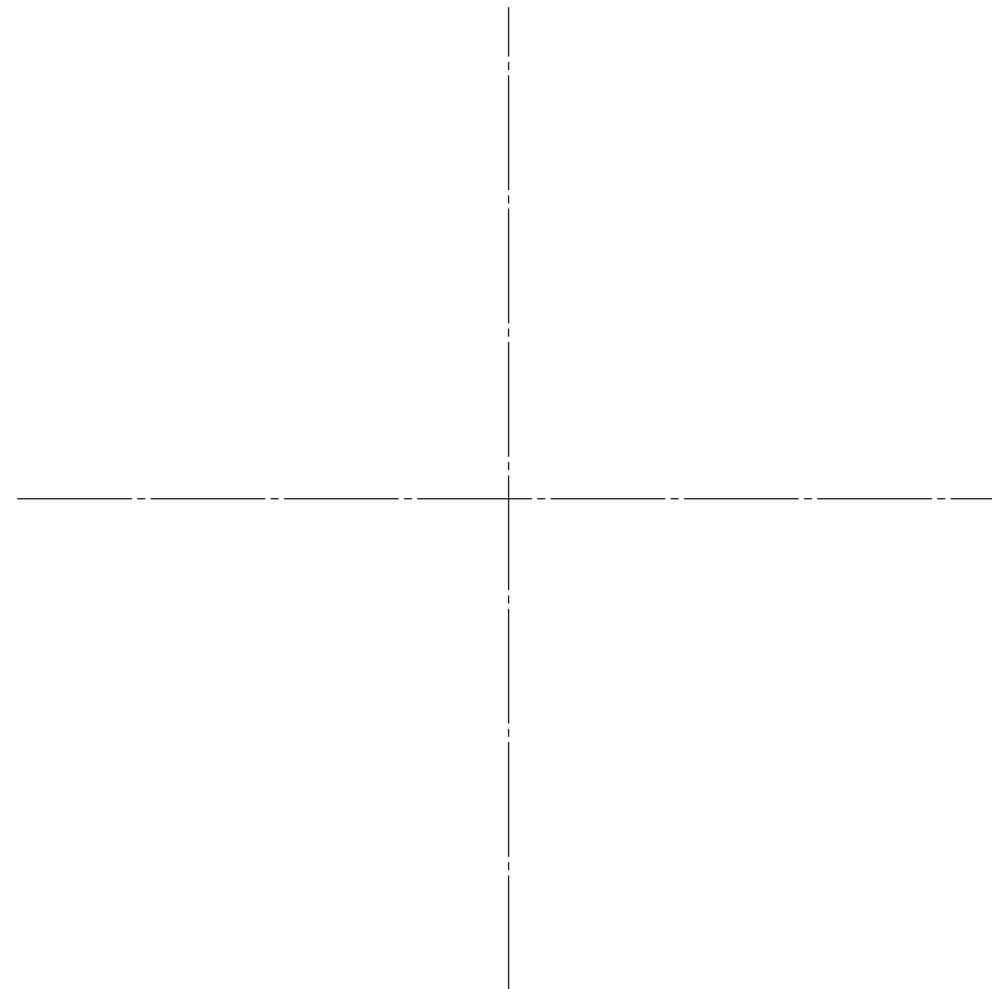
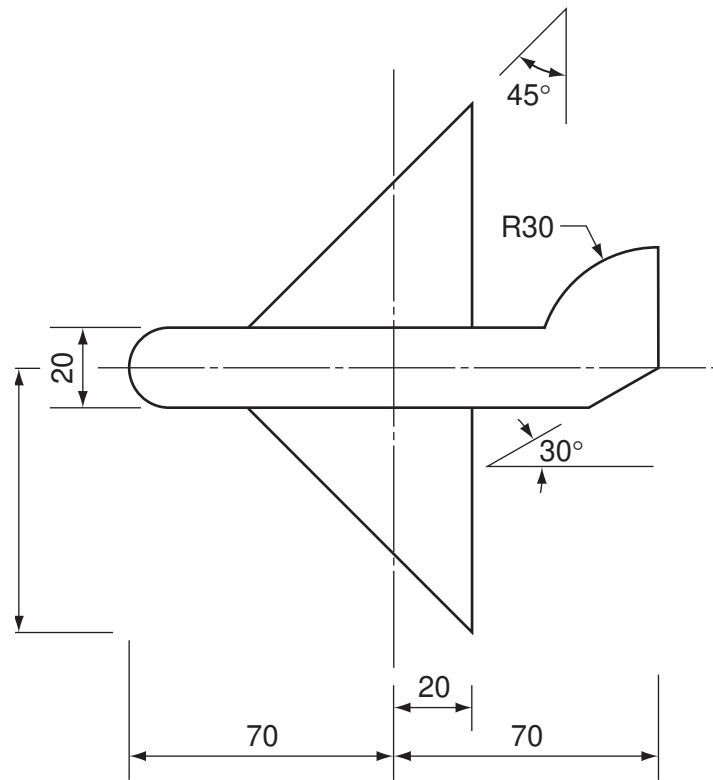

- (a) In the space to the right, draw the outline of the octagonal sign using the given side. [2]
- (b) Inside the octagonal sign, draw full size, the aircraft warning symbol on the centre lines given. [7]

one side of octagonal sign

0445/21 Oct/Nov 2010 **1 hour**

Centre Number

Candidate's Number

Candidate's Surname

Other Names

[Turn over]

For Examiner's use

A3 Passengers on long flights use masks to help them sleep.

The sketch on the right shows a design for a card sleep mask.

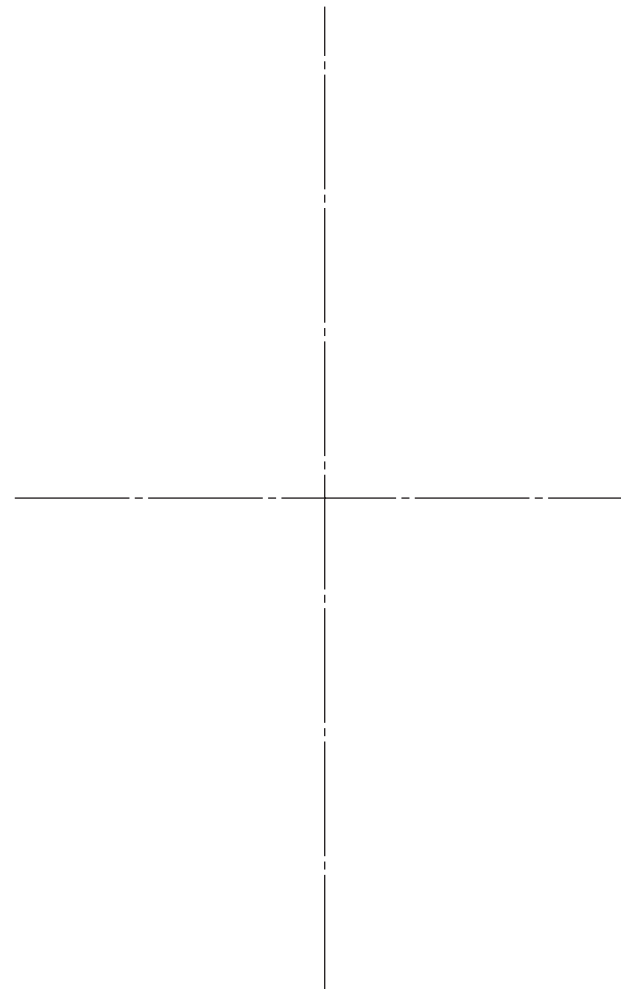
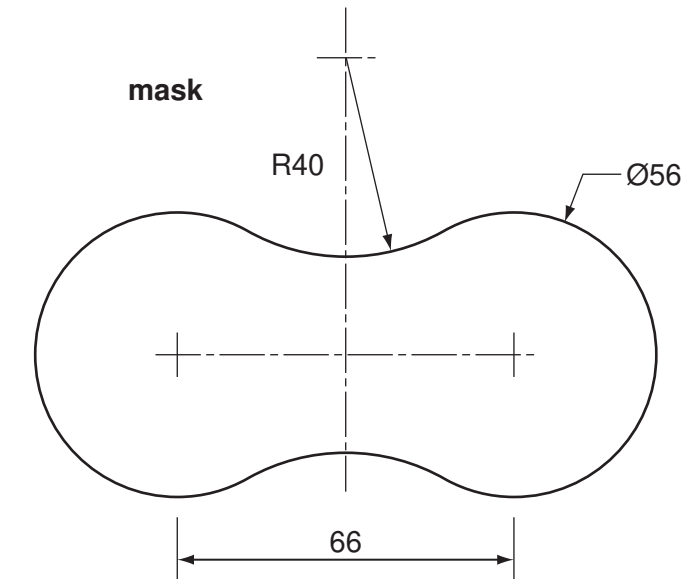
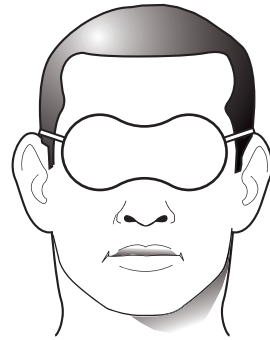

(a) Draw full size on the centre lines given, the outline of the mask. [8]

In use, the masks were found to be uncomfortable.

(b) In the space to the right, sketch a modification to the card mask that will give a better fit over the nose. [2]

Section B

Answer **either** question **B4** or **B5**.

B4 A pictorial view of a drinking cup and a card drinks tray is shown below.

The drinking cup is made from 2 mm polystyrene. The cup sits on the base of the card drinks tray.

The drinks tray is made from 4 mm thick card.

Draw to a scale of 1 : 2 in the space to the right:

- (a) a plan view and a front elevation of the card drinks tray; [5]
- (b) the centre positions of the four holes with drinking cup **C** in position on the plan view; [13]
- (c) drinking cup **C** in position on the front elevation; [3]
- (d) the correct size hole that is needed in the top surface to support the drinking cup in one of the three remaining positions on the plan view. [4]

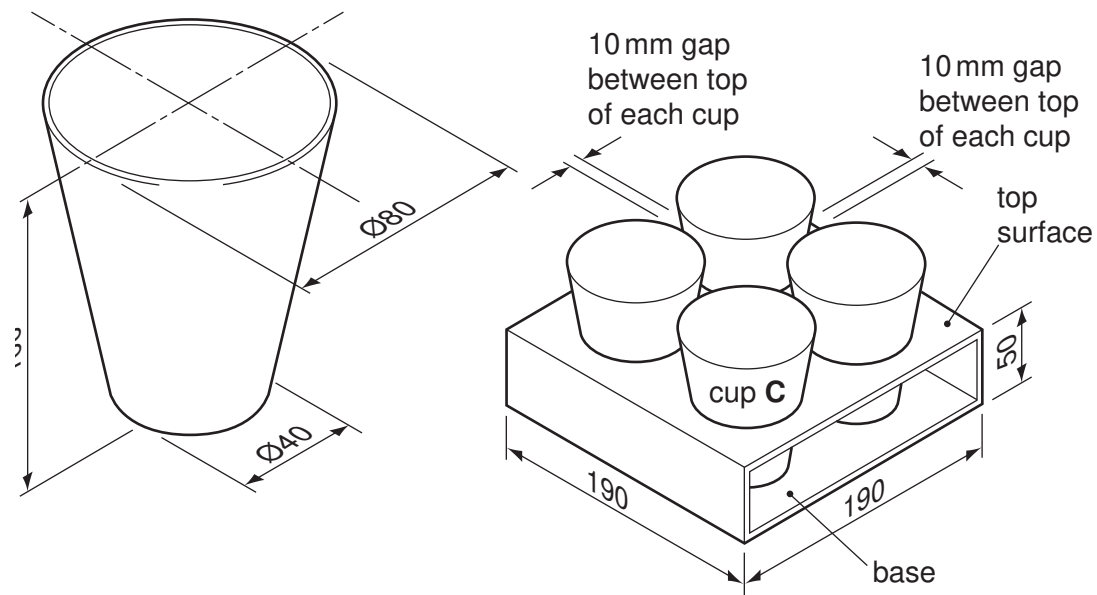

SCALE 1 : 2

0445/21 Oct/Nov 2010 1 hour
© UCLES 2010

Centre Number

Candidate's Number

Candidate's Surname

Other Names

[Turn over]

B5 The numbers and types of flight leaving a local airport over a five year period are shown below.

type of flight	year				
	2005	2006	2007	2008	2009
internal	52	75	60	65	70
short haul	85	90	96	104	108
long haul	30	45	52	58	65
freight	100	120	110	125	130
private	45	30	35	48	55

(c) The 2009 figures for freight and private flights are to be shown in an Annual report.

In the space below, sketch a symbol that will represent each type of flight.
The symbols must also represent the numbers of each type of flight.

Use colour and labels to enhance your illustration.

[7]

(a) In the space below, draw a pie chart to show how the flights in 2006 were distributed.

Label the **two** largest types of flight.

[9]

(b) In the space below, draw a suitable two-dimensional chart to show the increase in long haul flights from 2005 to 2009.

Use colour and labels to enhance your illustration.

[9]