

**Section A**

Answer **all** questions in this section.

The sketch below shows details of a logo design for a garden centre called 'FLOWERS'. The logo is an arrangement of shapes representing a flower.

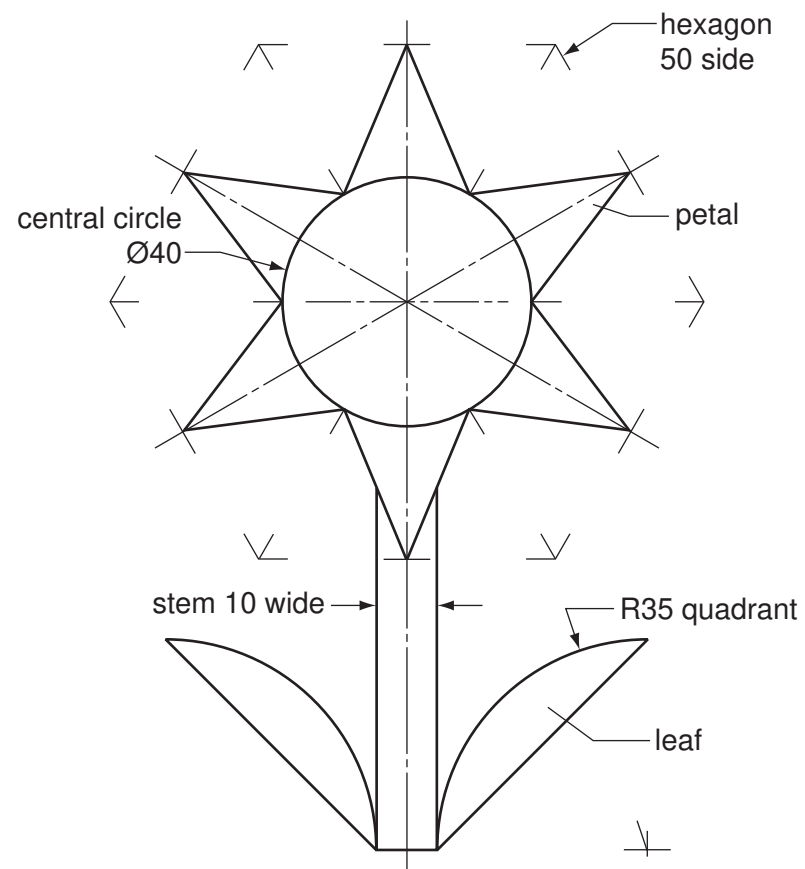

1 Draw full size on the centre lines given in the space to the right:

- the central circle Ø40;
- the hexagon 50 side.

Complete the flower by:

- joining the midpoint of the hexagon sides to the central circle to form the petals of the flower;
- adding the 10 wide stem;
- adding the second leaf. [9]

2 An incomplete signboard is drawn below the flower logo in the space to the right.

Complete the sign FLOWERS by adding:

- (a) the remaining part of the rectangular board;
- (b) the three remaining letters.

All the letters must be the same height and style as those given. [6]

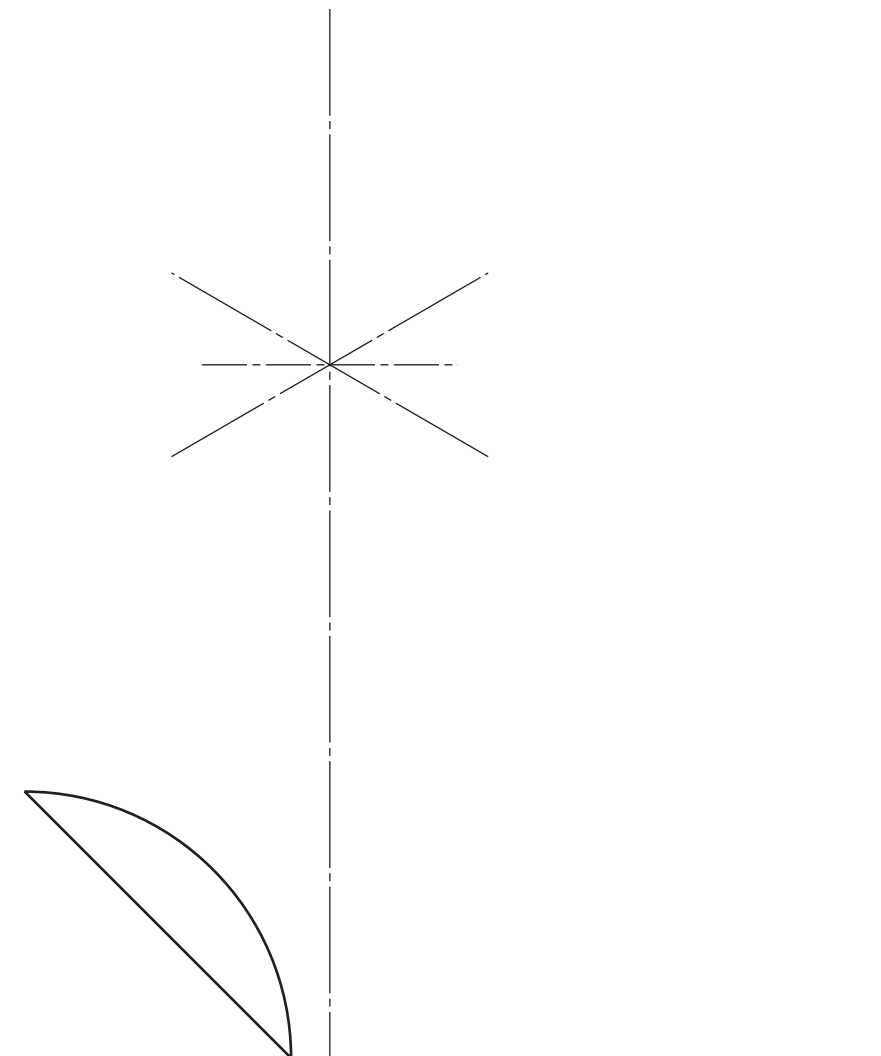

For Examiner's use

**0445/22** Oct/Nov 2010 **1 hour**  
© UCLES 2010

Centre Number .....	Candidate's Number .....	Candidate's Surname .....	Other Names .....	[Turn over]
---------------------	--------------------------	---------------------------	-------------------	-------------

**A3** The sketches show packaging for a house plant.

The sides fold up and are held together with a rubber band around the square neck formed by the petals as shown below.

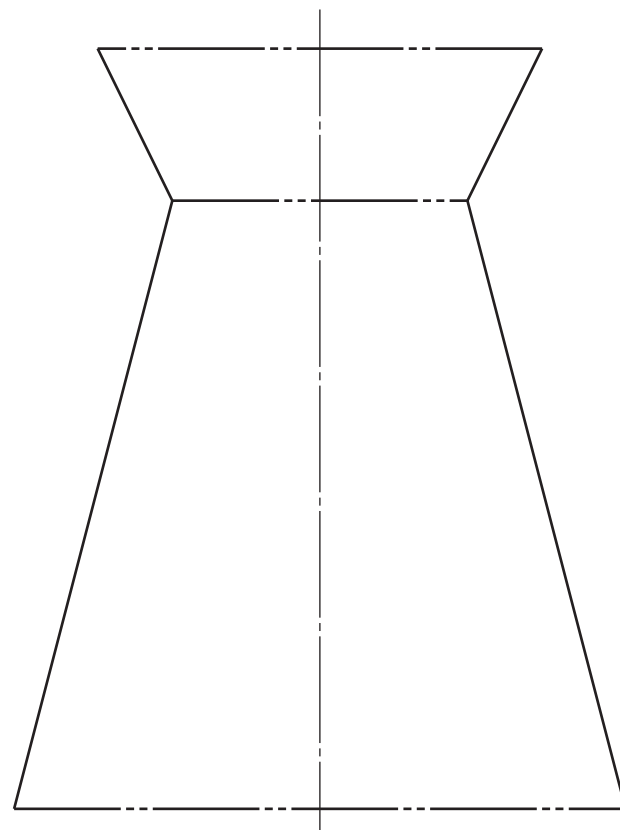
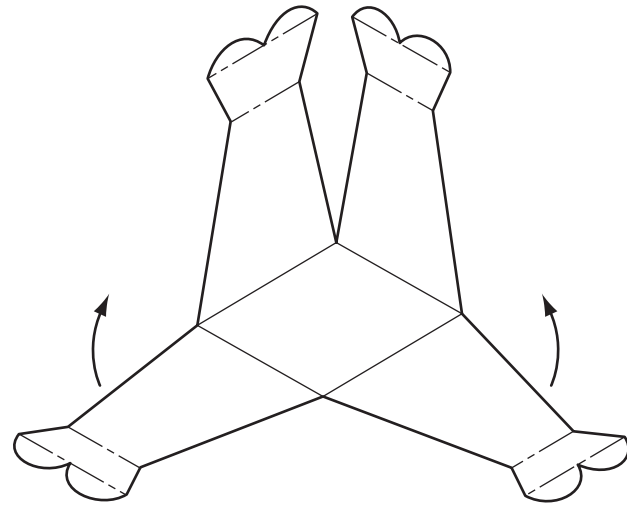
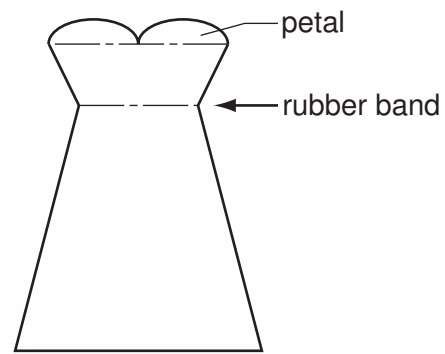

development (net) of one side

SCALE 1:1

- (a) Draw on the above view of one side, **two** arcs that would give the top a petal shape as shown in the sketches. [3]
- (b) Draw full size in the space provided to the right:
- a plan of the packaging when fully assembled; [4]
  - a side view of the packaging when fully assembled. [3]

Do **not** include the two arcs you have drawn in part (a).

**Section B**

Answer **either** question **B4** or **B5**.

**B4** A pictorial view of a plant pot and a card carry tray is shown below.

The plant pot is made from 2 mm polystyrene. The plant pots sit on the base of the card carry tray.

The carry tray is made from 4 mm thick card.

Draw to a scale of 1 : 2 in the space to the right:

- (a) a plan view and a front elevation of the card carry tray without the four holes; [5]
- (b) the centre positions of the four holes with plant pot **C** in position on the plan view; [13]
- (c) plant pot **C** in position on the front elevation; [3]
- (d) the correct size hole that is needed in the top surface to support the plant pot in **one** of the three remaining positions on the plan view. [4]

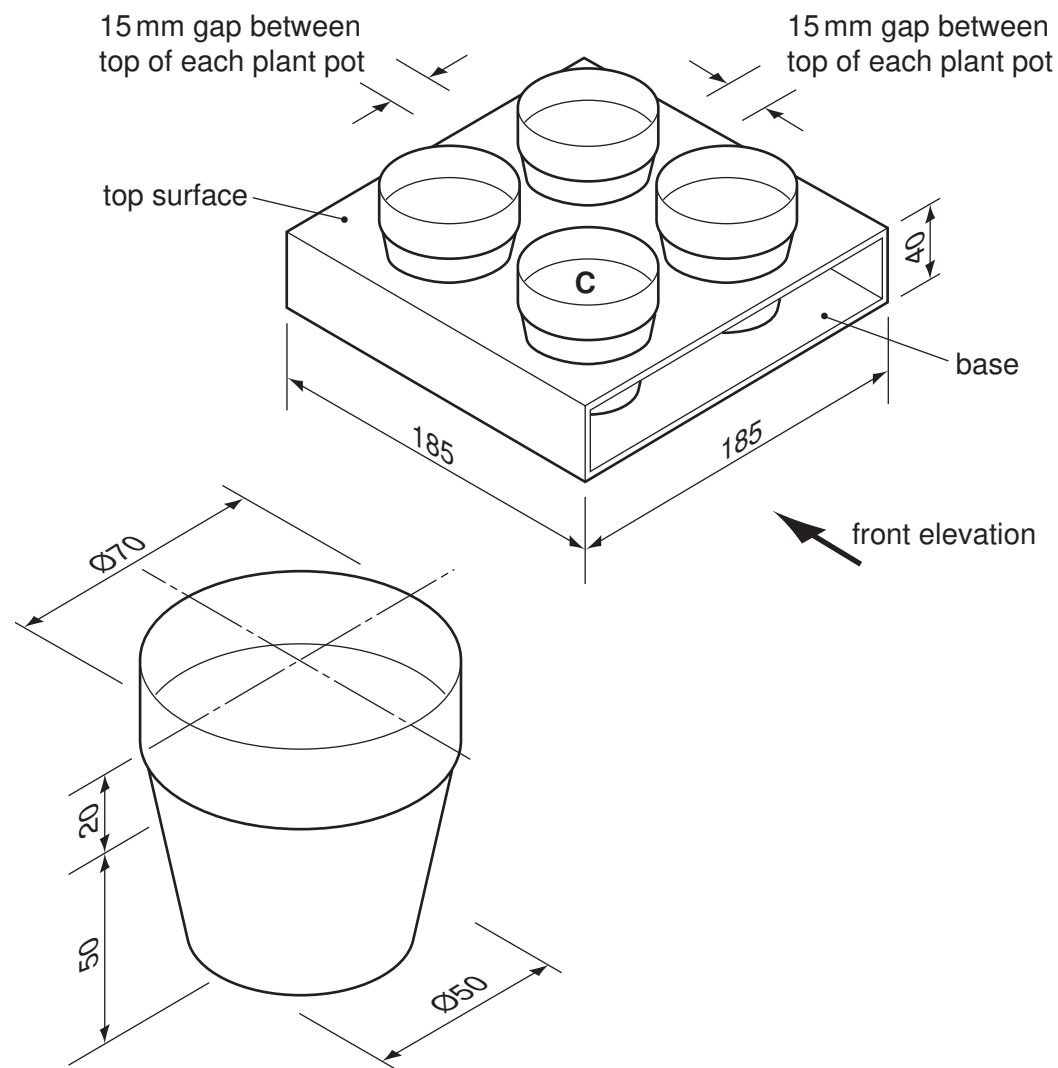

SCALE 1 : 2

**0445/22** Oct/Nov 2010 **1 hour**  
© UCLES 2010

Centre Number .....

Candidate's Number .....

Candidate's Surname .....

Other Names .....

[Turn over]

**B5** The number and types of products sold at a garden centre over a five year period are shown below.

product	year				
	2005	2006	2007	2008	2009
trees	520	750	600	650	700
shrubs	850	900	960	1040	1080
indoor plants	300	450	520	580	650
garden plants	1000	1200	1100	1250	1300
cut flowers	450	300	350	480	550

**(c)** The 2009 sales figures for garden plants and cut flowers are to be shown in an Annual report.

In the space below, sketch a symbol that will represent garden plants and a symbol that will represent cut flowers.  
The symbols must also represent the sales of each type of product in 2009.

Use colour and labels to enhance your illustration. [8]

**(a)** In the space below, draw a pie chart to show how the sales in 2006 were distributed.

Label the **two** largest types of product. [8]

**(b)** In the space below, draw a suitable three-dimensional chart to show the increase in sales of shrubs from 2005 to 2009.

Use colour and labels to enhance your illustration. [9]