

**Section A**  
Answer **all** questions in this section.

A sketch of a coffee mug with a square base is shown on the right.

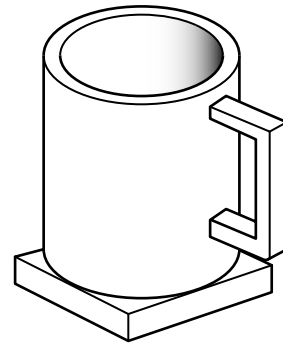

**A1 (a)** Complete the scale 1:2 orthographic views of the coffee mug by:

- (i) adding the missing lines to the side view; [5]
- (ii) adding one dimension to the plan; [2]
- (iii) adding the projection symbol in the given box. [3]

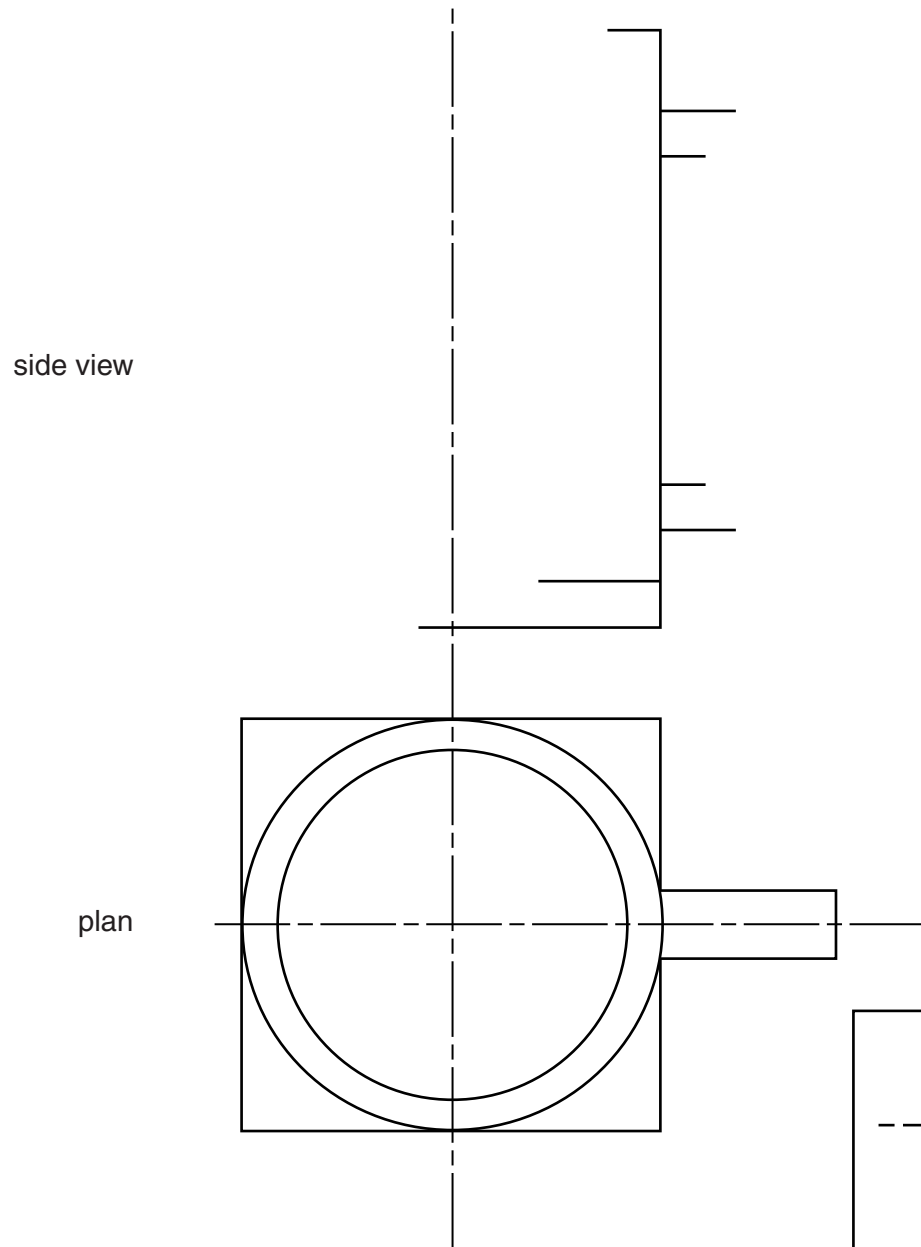

**A2 (a)** Complete the sectional plan view of the coffee mug below.

[2]

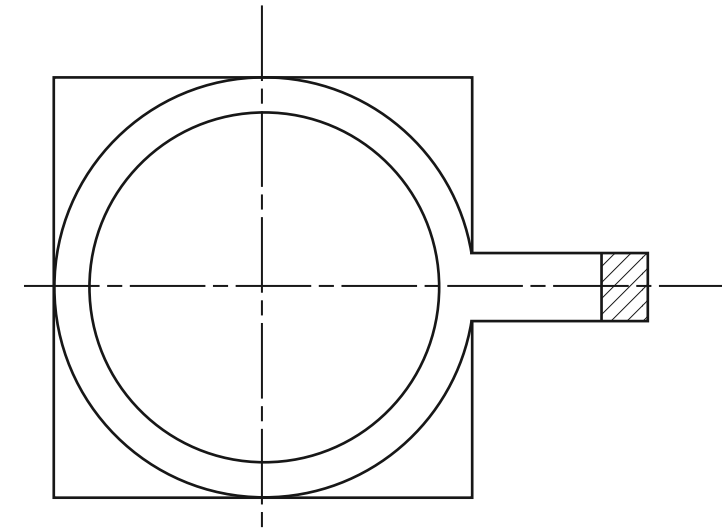

**(b)** A design is printed on the coffee mug in thermochromic ink. Describe how the thermochromic ink adds interest to the coffee mug.

.....

.....

.....

.....

.....

.....

.....

.....

.....

.....

[2]

For Examiner's use

**A3** An exploded view of a take away coffee cup is shown below.

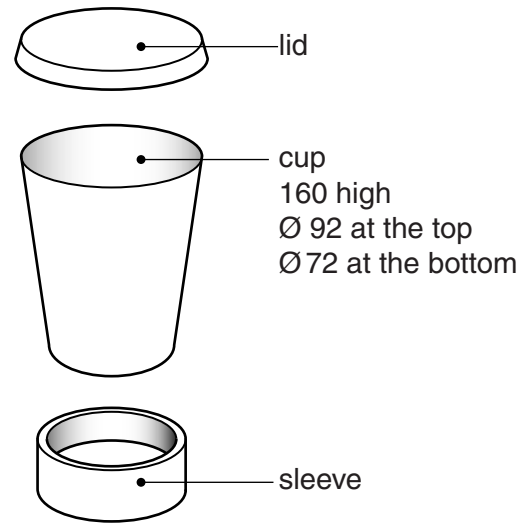

(a) In the space below draw a scale 1 : 2 planometric view of the cup.  
Do not include the lid or sleeve.

[4]

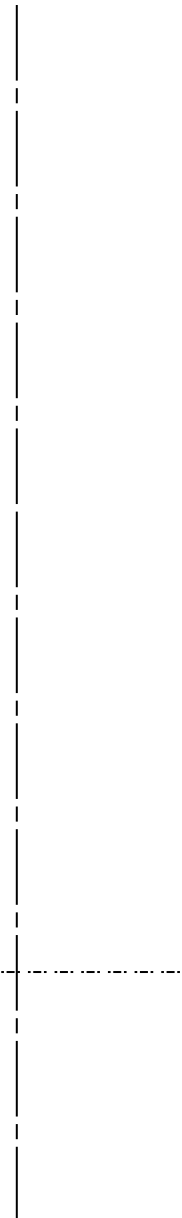

(b) The lid of the coffee cup is vacuum formed. Describe **three** main steps in the process of vacuum forming.

.....  
 .....  
 .....  
 .....  
 .....  
 .....  
 .....  
 .....  
 .....  
 ..... [3]

(c) The sleeve is made from corrugated card.

(i) In the space below draw a sectional view of corrugated card. [2]

(ii) Explain why corrugated card is used for the sleeve.

.....  
 .....  
 .....  
 .....  
 ..... [2]

