

Section B

Answer **either** question **B4** or **B5**.

B4 A café loyalty card is shown below. Customers are given a sticker when they buy a drink and once they have six stickers attached to the loyalty card they get a free drink.

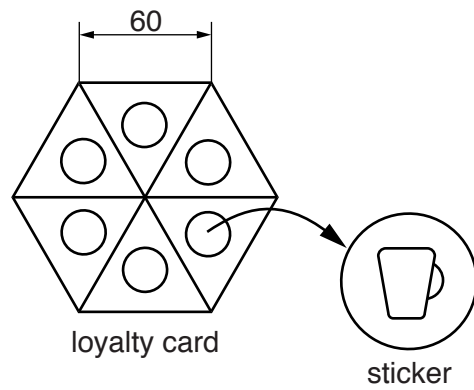

(b) A flow chart is printed on the back of the loyalty card to show customers what they have to do to get a free drink. Complete the flow chart below by adding four more stages. [9]

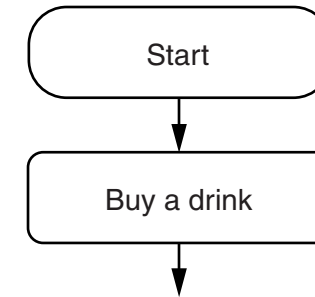

(a) On the centre lines below construct a full size view of the loyalty card by:

- (i)** completing the drawing of the regular hexagon with length of side 60; [2]
- (ii)** dividing the hexagon into six equal triangles; [3]
- (iii)** adding a $\varnothing 20$ circle in the middle of each triangle. [7]

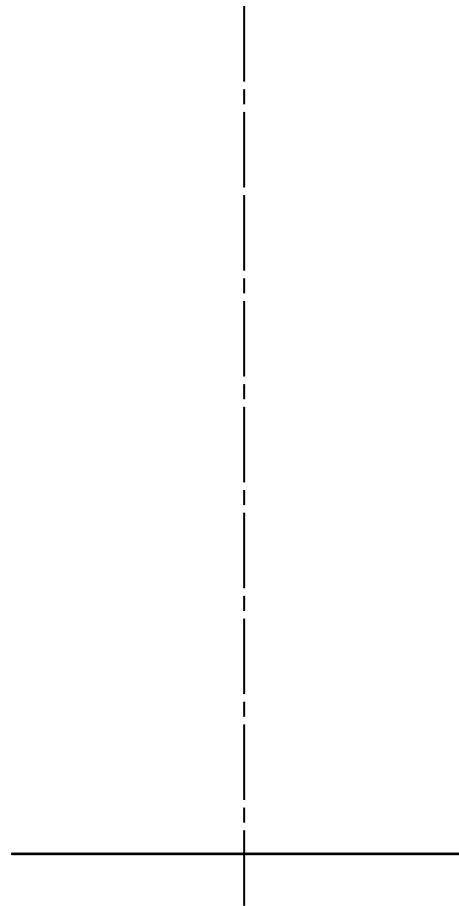

(c) 10 000 loyalty cards are printed by lithography.

- (i)** Name the commercial process used to cut out the loyalty cards. [1]
.....[1]
- (ii)** Give **three** examples of where ICT could be used in the design and manufacture of the loyalty card.
 - 1.[1]
 - 2.[1]
 - 3.[1]

For
Examiner's
use

0445/22 May/June 2015 **1 hour**
© UCLES 2015 DC (ST/FD) 109132

Centre Number Candidate Number Candidate Surname Other Names **[Turn over]**

B5 A sketch of a package for biscuits is shown below.

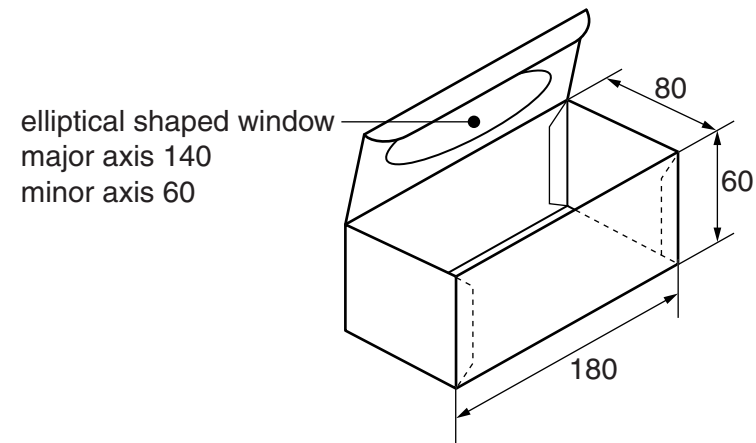

(b) The fold in flap needs to lock in place without the use of glue. In the space below use sketches and notes to show a design for a locking flap. [3]

(a) Complete the scale 1:2 development (net) of the package for the biscuits below by:

- (i) constructing the elliptical shaped window on the given top surface; [7]
- (ii) drawing the remaining surfaces and glue tabs of the development (net). [9]

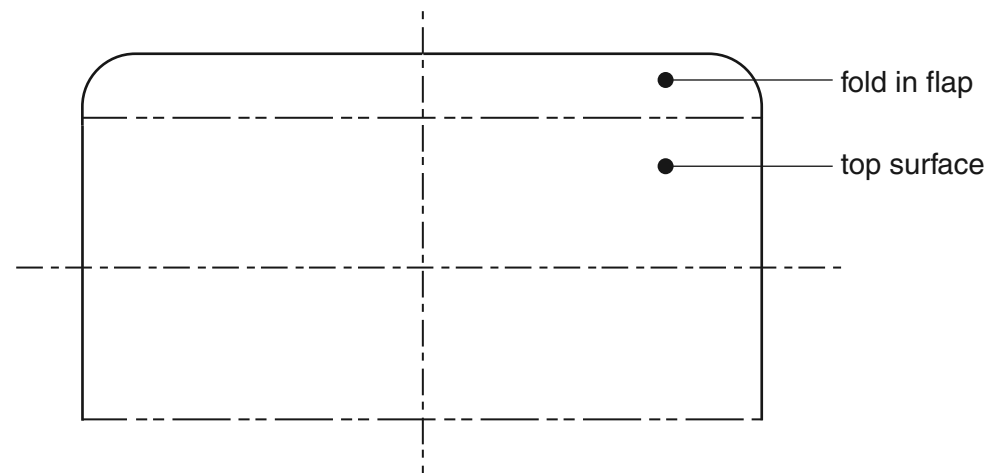

(c) Complete the table below to explain **three** pieces of information that are printed on the package for the biscuits.

| Symbol | Explanation |
|--------------|---|
| | <p>This means the card used to make the package can be recycled.</p> <p>[2]</p> |
| | <p>.....</p> <p>.....</p> <p>.....</p> <p>.....</p> <p>.....</p> <p>[2]</p> |
| <p>200g </p> | <p>.....</p> <p>.....</p> <p>.....</p> <p>.....</p> <p>.....</p> <p>[2]</p> |