



Cambridge International Examinations
Cambridge International General Certificate of Secondary Education

CANDIDATE NAME

CENTRE NUMBER

CANDIDATE NUMBER



DESIGN AND TECHNOLOGY **0445/32**
Paper 3 Resistant Materials **May/June 2017**
1 hour

Candidates answer on the Question Paper.
No Additional Materials are required.

READ THESE INSTRUCTIONS FIRST

Write your Centre number, candidate number and name on all the work you hand in.
Write in dark blue or black pen.
You may use an HB pencil for any diagrams, graphs or rough working.
Do not use staples, paper clips, glue or correction fluid.
DO NOT WRITE IN ANY BARCODES.

Section A
Answer **all** questions in this section.

Section B
Answer **one** question in this section.

You may use a calculator.

At the end of the examination, fasten all your work securely together.
The number of marks is given in brackets [] at the end of each question or part question.
The total of the marks for this paper is 50.

This document consists of **15** printed pages and **1** blank page.

Section A

Answer **all** questions in this section.

- 1 Fig. 1 shows two pieces of hardwood that have been glued together.

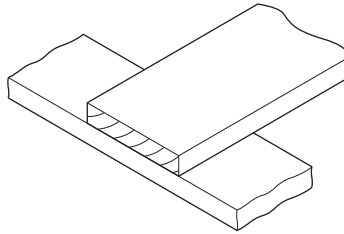

Fig. 1

From the list below circle the type of glue that would provide the strongest joint.

contact adhesive

hot melt glue gun

PVA

[1]

- 2 Complete the drawing below to show odd leg calipers.

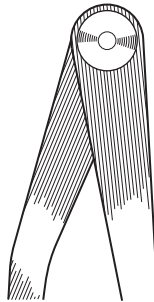

[2]

- 3 Complete the statement by adding the correct term from the list below.

lightweight

recycled

smart

dense

A thermochromic material changes colour with changes in temperature.

This is an example of a material.

[1]

- 4 Fig. 2 shows the end of a length of wood.
Draw on Fig. 2 to show a groove and a rebate.

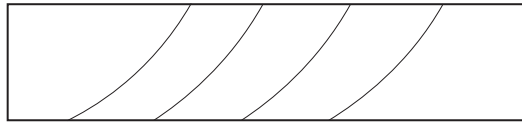

Fig. 2

[2]

- 5 Fig. 3 shows four items used to fasten materials together.

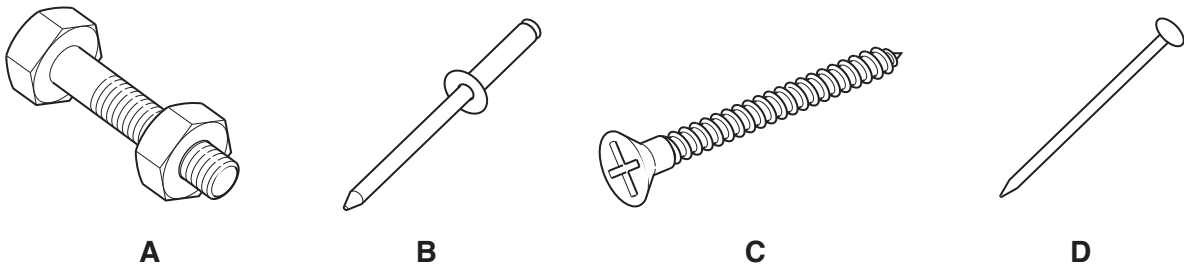

Fig. 3

Name each of the items **A**, **B**, **C** and **D** shown in Fig. 3.

- A**
- B**
- C**
- D** [4]

- 6 Fig. 4 shows three layers of a sheet of plywood.

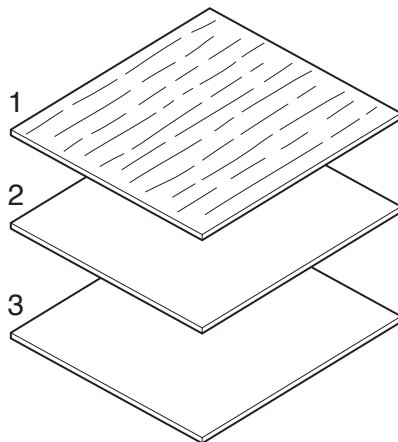
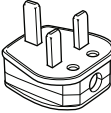



Fig. 4

Complete Fig. 4 by drawing the grain direction on layers 2 and 3 to show how plywood is constructed. [1]

7 The table below shows products made mainly from plastic.
Complete the table by naming a suitable plastic for each product.

Product	Name of plastic
 <p>electric plug body</p>	
 <p>plastic blister packaging</p>	
 <p>knife handle</p>	

[3]

8 Fig. 5 shows a manufactured board.

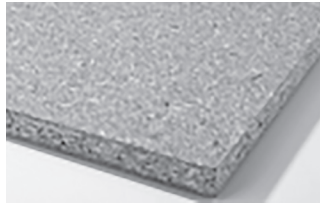

Fig. 5

(a) Name the manufactured board.

.....[1]

(b) Describe briefly how the manufactured board shown in Fig. 5 is made.

.....

[2]

(c) The manufactured board shown in Fig. 5 is widely used in the production of mass-produced furniture.

From the list below circle the most important benefit of using this manufactured board.

weight **appearance** **cost** **strength** [1]

9 Fig. 6 shows a mild steel bracket for a hanging basket.

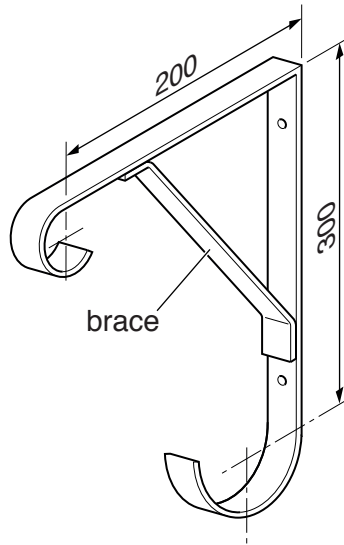

Fig. 6

(a) State a suitable thickness of mild steel strip for the bracket.

.....[1]

(b) Give **two** methods of joining the brace to the bracket permanently.

1

2[2]

10 Fig. 7 shows a toast rack made from metal.

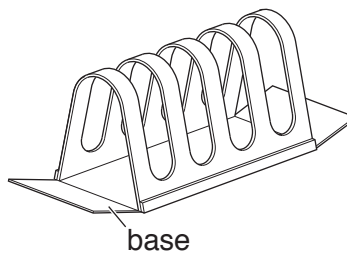

Fig. 7

(a) (i) Name a suitable ferrous metal for the toast rack.

.....

(ii) Name a suitable non-ferrous metal for the toast rack.

.....[2]

(b) Give **two** reasons why a base has been fitted to the toast rack.

1

2[2]

Section B

Answer **one** question from this section.

11 Fig. 8 shows views of an artist's drawing board.

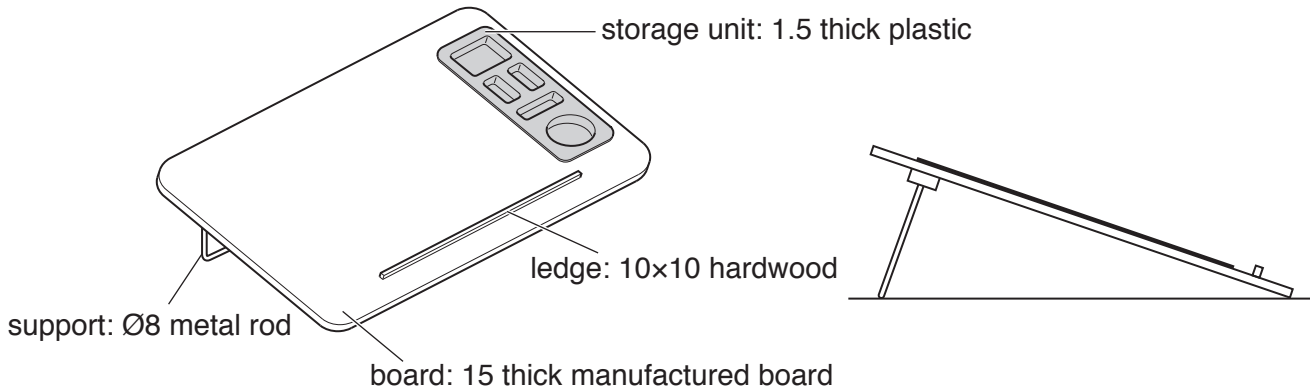

Fig. 8

(a) Describe **two** good design features of the artist's drawing board.

1

2[2]

(b) Complete the parts list below by naming a specific material for each of the parts of the drawing board.

Part	Number Required	Length × Width × Thickness	Specific material
board	1	650 × 450 × 15	
storage unit	1	300 × 100 × 1.5	
ledge	1	400 × 10 × 10	
support	1	750 × Ø8	

[4]

(c) (i) Name a portable power saw that could be used to cut out the shape of the drawing board from a large sheet of manufactured board.

.....[1]

(ii) Give **one** safety precaution, other than wearing eye protection, that must be taken when using portable power tools.

.....[1]

(d) The storage unit that will fit into the drawing board is produced by vacuum forming.

(i) Describe **two** important features of the design of the former used to vacuum form the storage unit.

1

2[2]

(ii) Explain why it is important to heat the plastic to the correct temperature when vacuum forming.

.....

.....[2]

(e) Fig. 9 shows the ends of the support fixed into hardwood blocks.

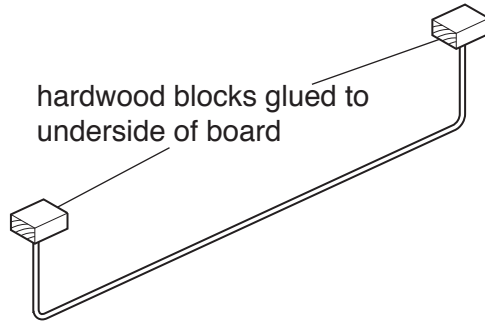

Fig. 9

(i) Explain why the designer has used hardwood blocks for the ends of the support to fit into rather than drilling holes directly into the drawing board.

.....

.....

.....[2]

(ii) The support will be made by bending one length of Ø8 metal rod to shape. Use sketches and notes to show how the Ø8 metal rod could be bent to shape. Name the tools and equipment used.

[3]

- (f) Use sketches and notes to show a different method of supporting the drawing board to that shown in Fig. 8.
Include details of all materials and constructions used.

[6]

- (g) Give **two** benefits of using a portable power sander to prepare the surface of the drawing board before a finish is applied.

1

2[2]

12 Fig. 10 shows a bird feeder made from wood and plastic.

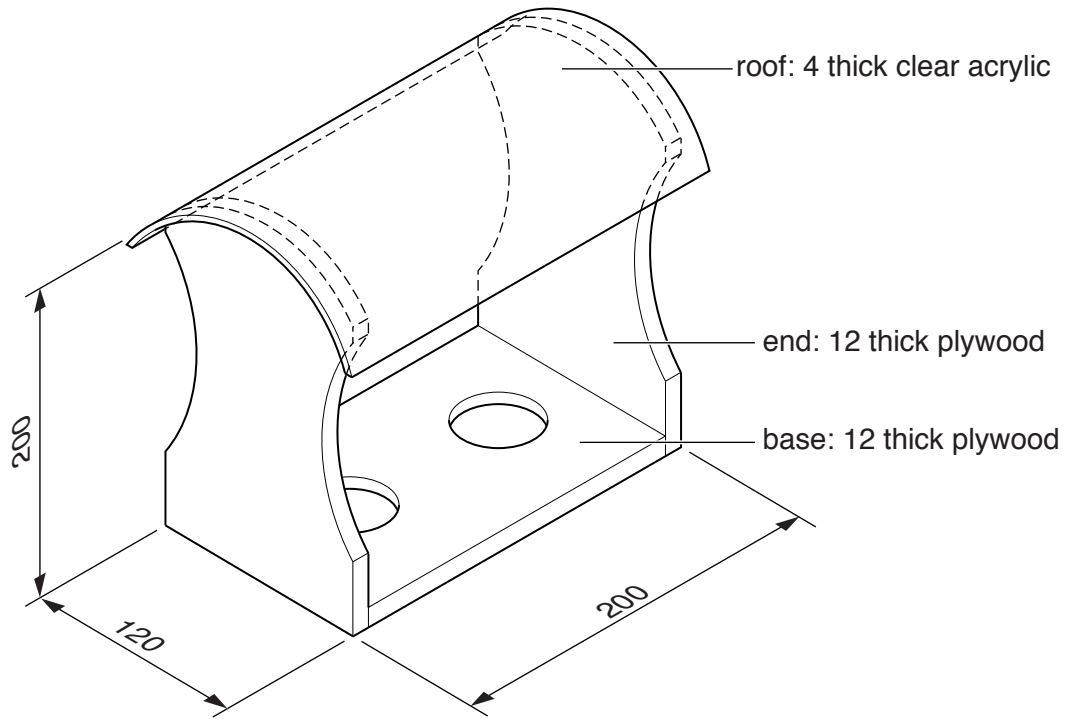

Fig. 10

(a) Give **two** reasons why acrylic is a good choice of material for the roof of the bird feeder.

- 1
- 2[2]

(b) Fig. 11 shows a tool that could be used to produce the Ø50 holes in the base of the bird feeder.

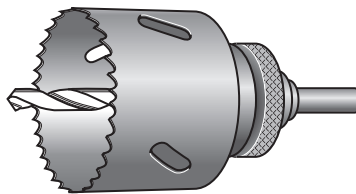

Fig. 11

Name the tool shown in Fig. 11.

.....[1]

(c) Fig. 12 shows one end of the bird feeder marked out ready to be cut to shape.

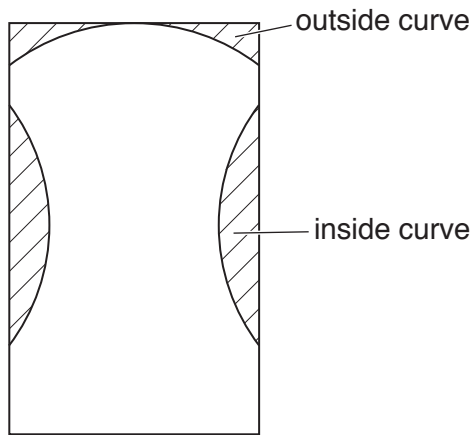

Fig. 12

(i) Name a machine saw that could be used to cut out the shape.

.....[1]

(ii) Name a tool that could be used to finish the inside curve.

.....[1]

(iii) Give **one** safety precaution you would take when using a disc sander to finish the outside curve.

.....[1]

(d) Use sketches and notes to show how the base and ends could be joined together permanently.

[3]

(e) Fig. 13 shows the roof of the bird feeder marked out on a sheet of acrylic.

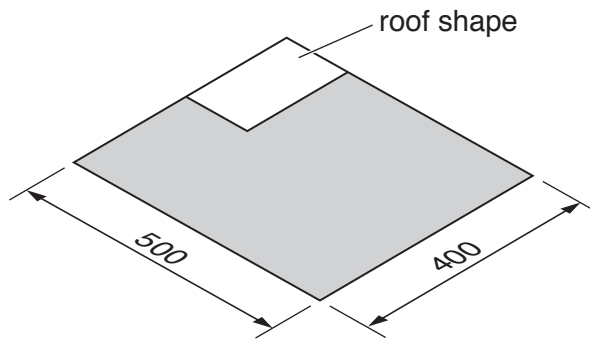

Fig. 13

(i) Name **two** ways of marking lines on the surface of acrylic.

1

2 [2]

(ii) When sawing acrylic there is a possibility that it could crack. Describe how this could be prevented.

.....

 [2]

(f) Use sketches and notes to show how the curved shape of the roof could be produced.

- (g) Two plastic bowls are needed to fit into the holes in the base of the bird feeder. Fig. 14 shows the former that will be used to vacuum form the plastic bowls.

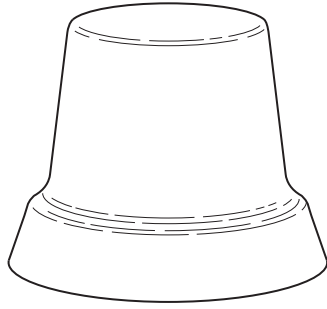

Fig. 14

- (i) Describe **two** features of the design of the former that will allow the plastic bowls to be released from the former when vacuum formed.
- 1
- 2 [2]
- (ii) Use sketches and notes to show how **one** plastic bowl could be produced by vacuum forming.

13 Fig. 15 shows views of a computer desk manufactured as flat-pack for self-assembly. The end frames, back rail and supports are made from hardwood.

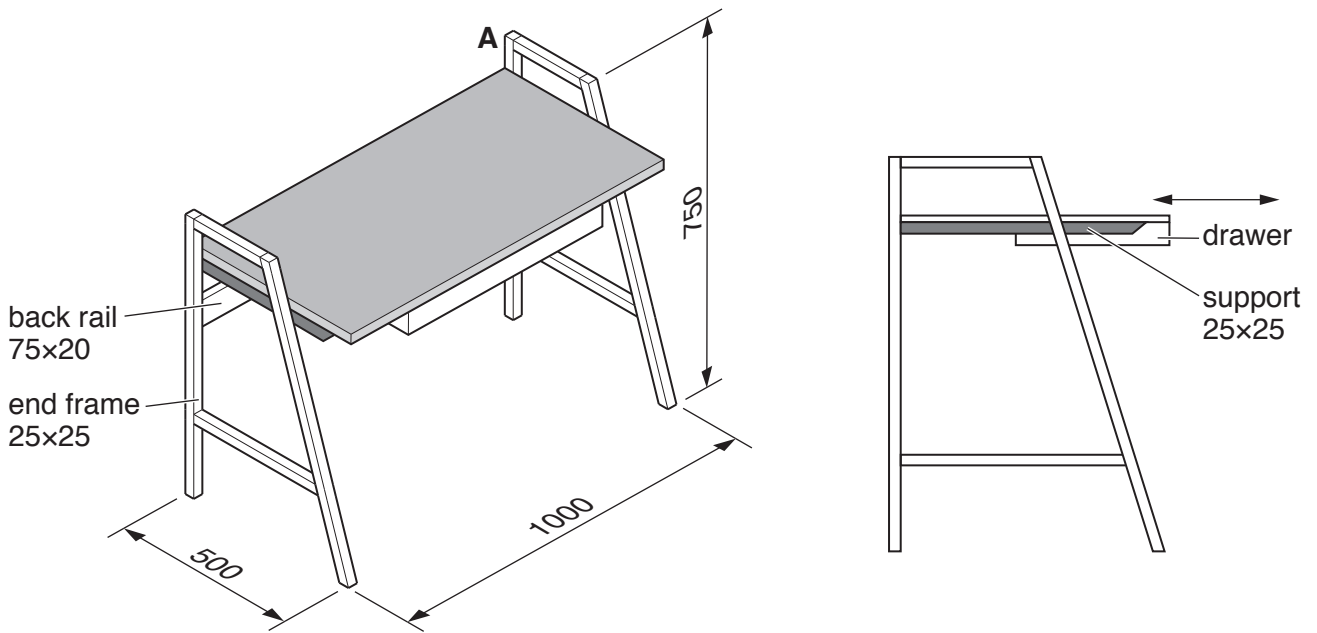

Fig. 15

(a) The computer desk top will be made from manufactured board.

(i) Name a suitable manufactured board for the desk top.

.....[1]

(ii) Give a reason for your choice of manufactured board.

.....[1]

(b) (i) Sketch and name a permanent joint that could be used at corner A in Fig. 15.

[4]

- (ii) Fig. 16 shows an exploded view of a support and an end frame. Use sketches and notes to show how the support could be joined to the end frame using a temporary fixing in the space below.

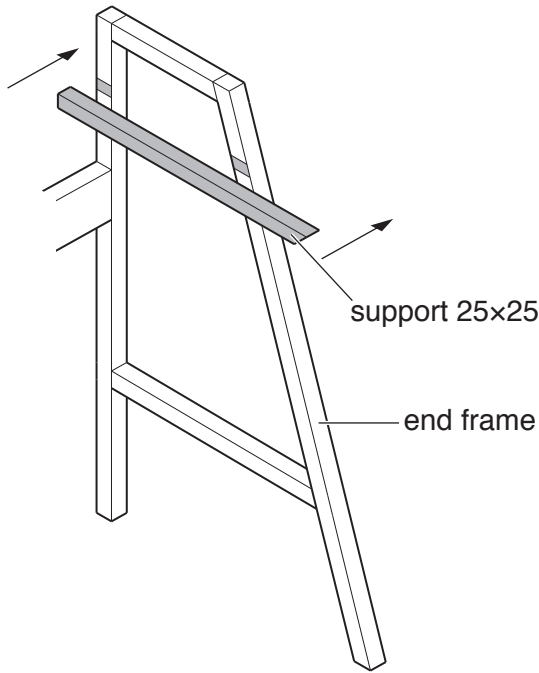

Fig. 16

[3]

- (c) The hardwood parts of the computer desk will be finished with polyurethane varnish.

- (i) Describe how each of the items listed below could be used to prepare the surfaces of the hardwood parts before a polyurethane varnish finish is applied.

Medium grade glasspaper

.....

Fine grade glasspaper

.....

Damp cloth

.....

Cork block

..... [4]

- (ii) Give **two** reasons why polyurethane varnish is a suitable finish for the computer desk.

1

2 [2]

(d) Explain how the designer has decided on the measurements of:

(i) the length and width of the computer desktop;

.....

(ii) the height of the computer desk top above the ground.

.....[2]

(e) Fig. 17 shows details of a drawer that will be supported below the computer desk top.

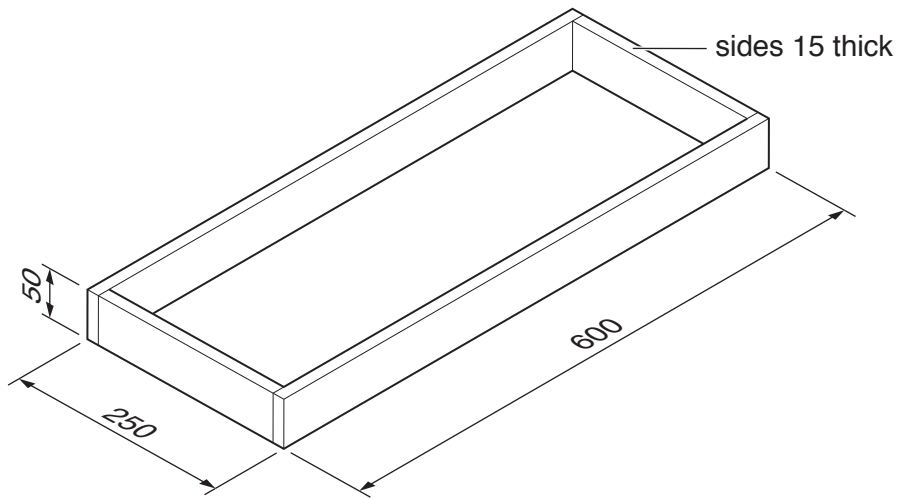

Fig. 17

Use sketches and notes to show how the drawer could be supported below the computer desk top and made to slide in and out as shown in Fig. 15. Include details of materials, constructions and **two** important sizes.

[6]

(f) Many items of furniture are designed for self-assembly. Give **two** drawbacks of self-assembly furniture.

1

2[2]

BLANK PAGE

Permission to reproduce items where third-party owned material protected by copyright is included has been sought and cleared where possible. Every reasonable effort has been made by the publisher (UCLES) to trace copyright holders, but if any items requiring clearance have unwittingly been included, the publisher will be pleased to make amends at the earliest possible opportunity.

To avoid the issue of disclosure of answer-related information to candidates, all copyright acknowledgements are reproduced online in the Cambridge International Examinations Copyright Acknowledgements Booklet. This is produced for each series of examinations and is freely available to download at www.cie.org.uk after the live examination series.

Cambridge International Examinations is part of the Cambridge Assessment Group. Cambridge Assessment is the brand name of University of Cambridge Local Examinations Syndicate (UCLES), which is itself a department of the University of Cambridge.