

Section A

Answer **all** questions in this section.

The drawing below shows details of a logo used by a water sports centre.

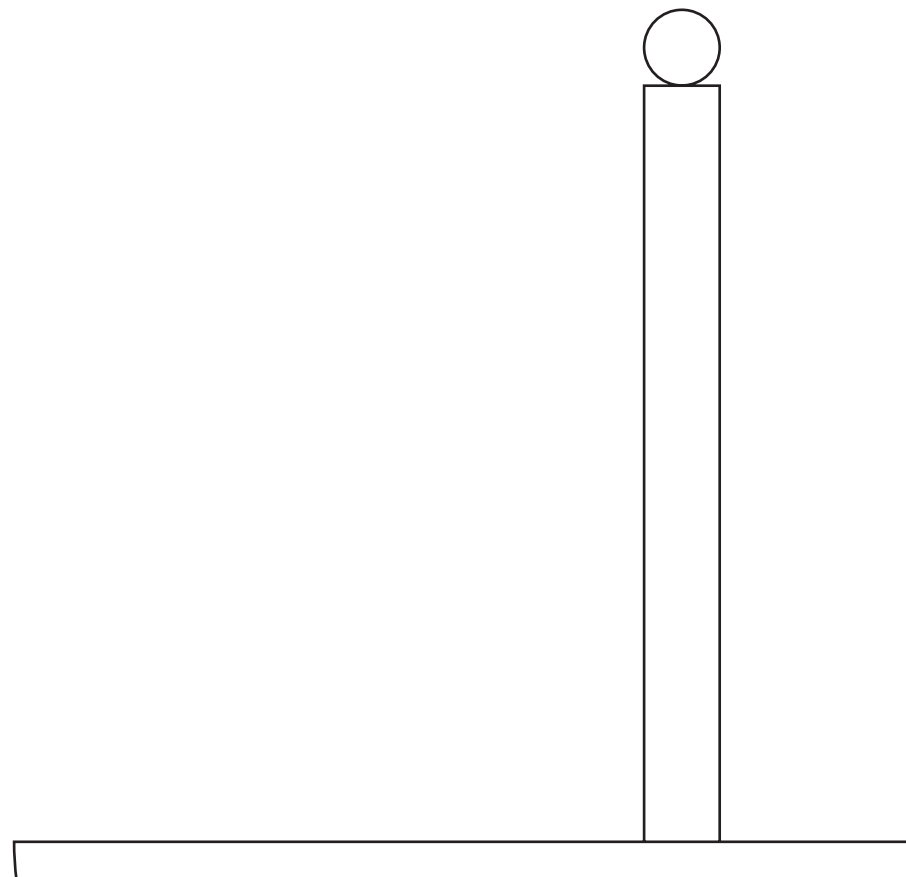
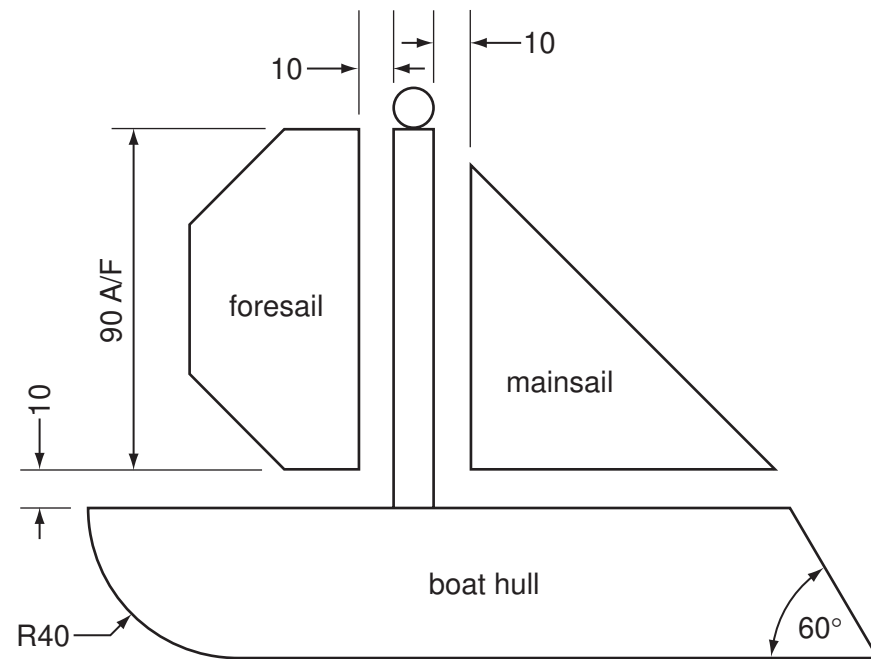

Complete the full size view of the logo in the space provided to the right by drawing:

- (a) the 80 × 80 right-angled triangle representing the main sail; [2]
- (b) the boat hull including the R40 quadrant representing the bow of the boat; [4]
- (c) the half octagon 90 A/F representing the foresail. [3]

An incomplete signboard for the water sports centre is drawn to the right.

Complete the sign WATER SPORTS CENTRE by adding:

- (a) the remaining part of the signboard; [1]
- (b) the **two** missing letters. [5]

All the missing letters must be to the same height and style as those given.



For
Examiner's
use

0445/22 May/June 2011 **1 hour**

Centre Number

Candidate's Number

Candidate's Surname

Other Names [Turn over]

A3 A marker buoy used at the water sports centre is drawn in the orthographic views below.

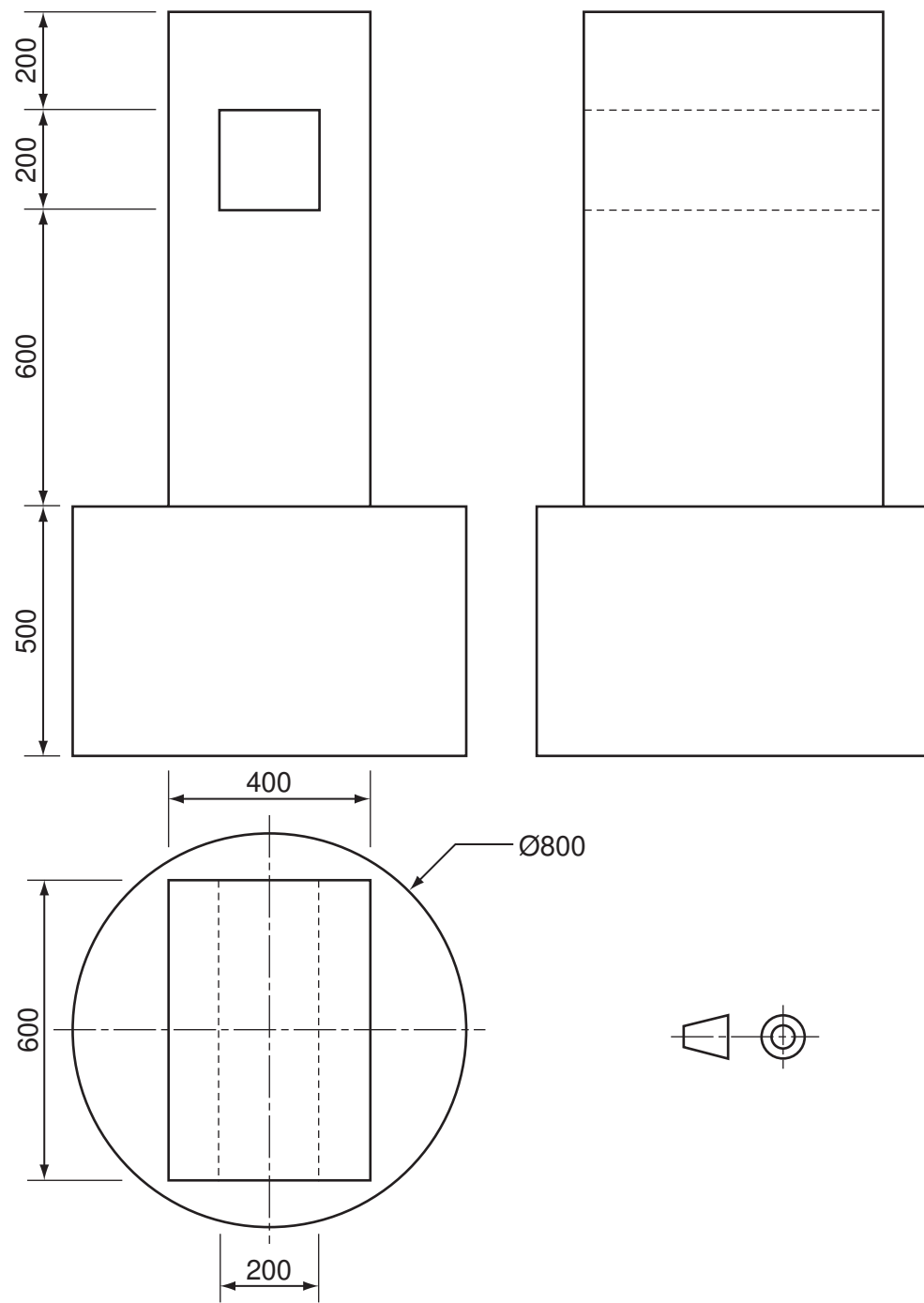

- (a) In the space to the right, draw an isometric view of the marker buoy to a scale of 1:10. [7]
- (b) Apply thick and thin line technique to the isometric drawing to enhance its appearance. [3]

Section B

Answer **either** question **B4** or **B5**.

B4 The sketch below shows a collection box used at the water sports centre for the 'lifebelt' charity. The box is made from a one-piece development of thin card.

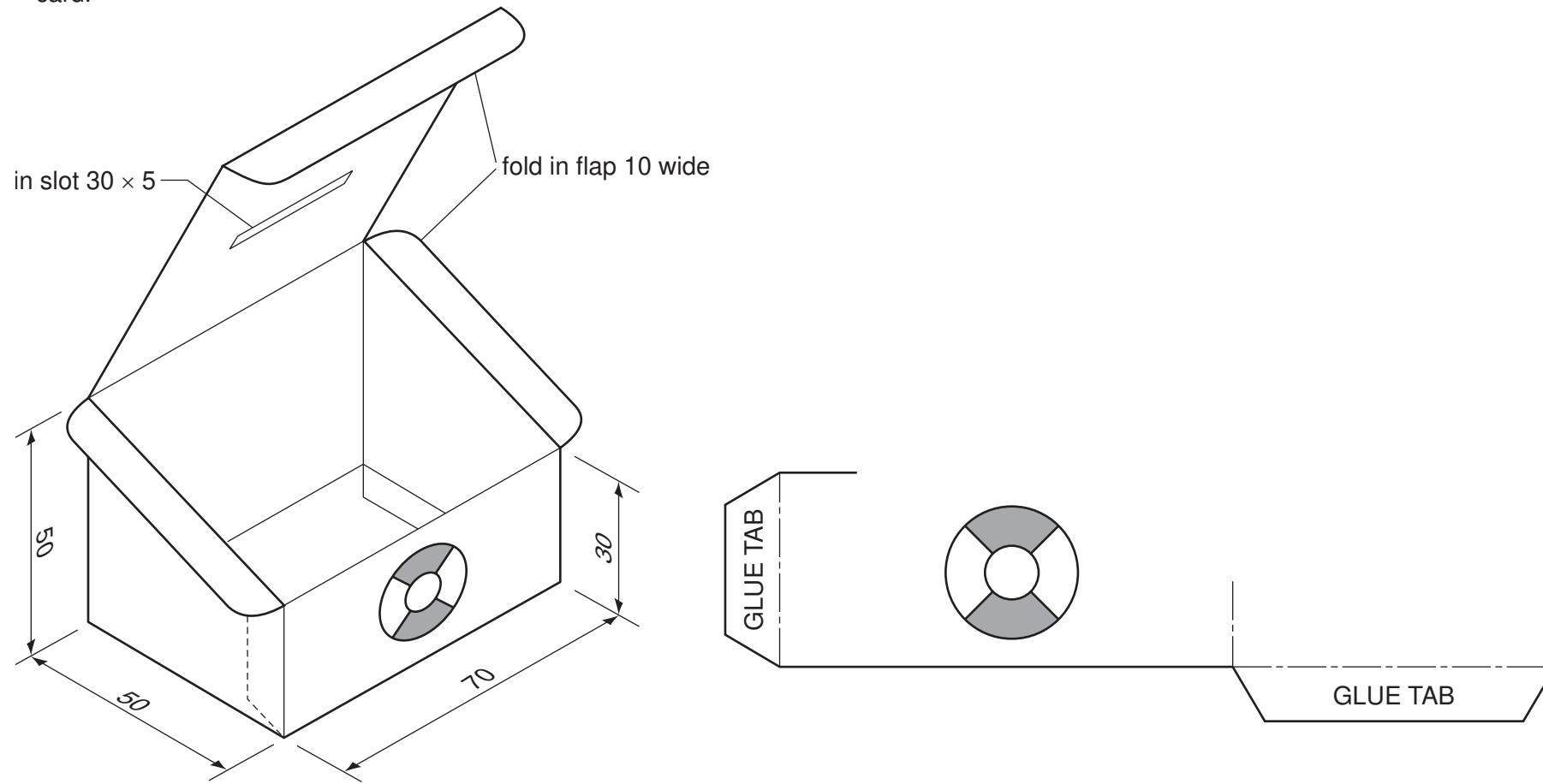

(a) In the space on the right, complete the drawing of a full size, one-piece development (net) of the box. The front of the box and one glue tab have been started for you. Include the coin slot and all the glue tabs and flaps required to make the box. [21]

(b) In the space below, use sketches and notes to show a method of securing the lid of the box in a closed position without using glue. [4]

0445/22 May/June 2011 1 hour

© UCLES 2011

Centre Number

Candidate's Number

Candidate's Surname

Other Names

[Turn over]

B5 The drawings below show details of a greetings card that is to be sent to water sports centre members. The card is pre-punched so that the sides can be folded back.

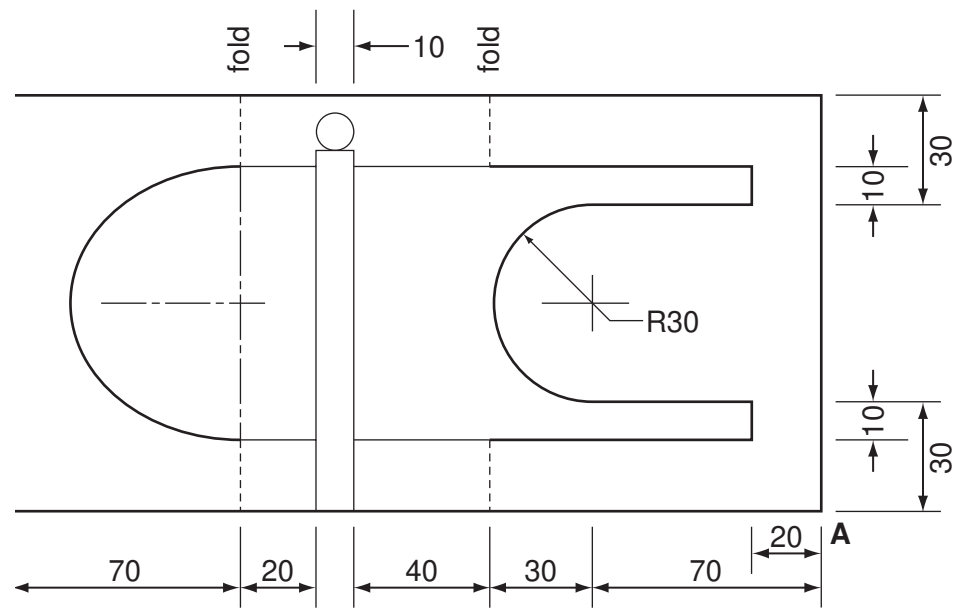

The card can be made to stand when the sides are folded back.

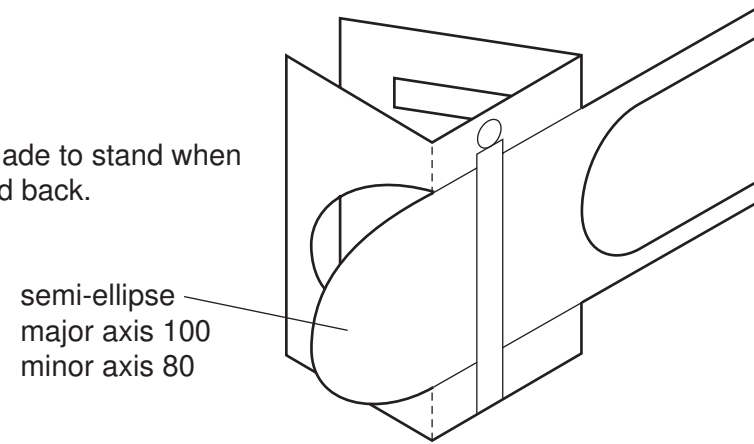

- (a) Draw on the centre lines given to the right, a full size view of the complete card before folding. Corner **A** has been given. [18]
- (b) Project a plan from the full size view to show the sides folded back until they touch. [3]
- (c) In the space below, use sketches and notes to show a method of joining the two folded back sides without the use of glue. [4]

