

**Section A**

Answer **all** questions in this section.

A shop selling sweets, chocolates and ice-cream is called LUCKY TREATS.

The design for the signboard is shown below.

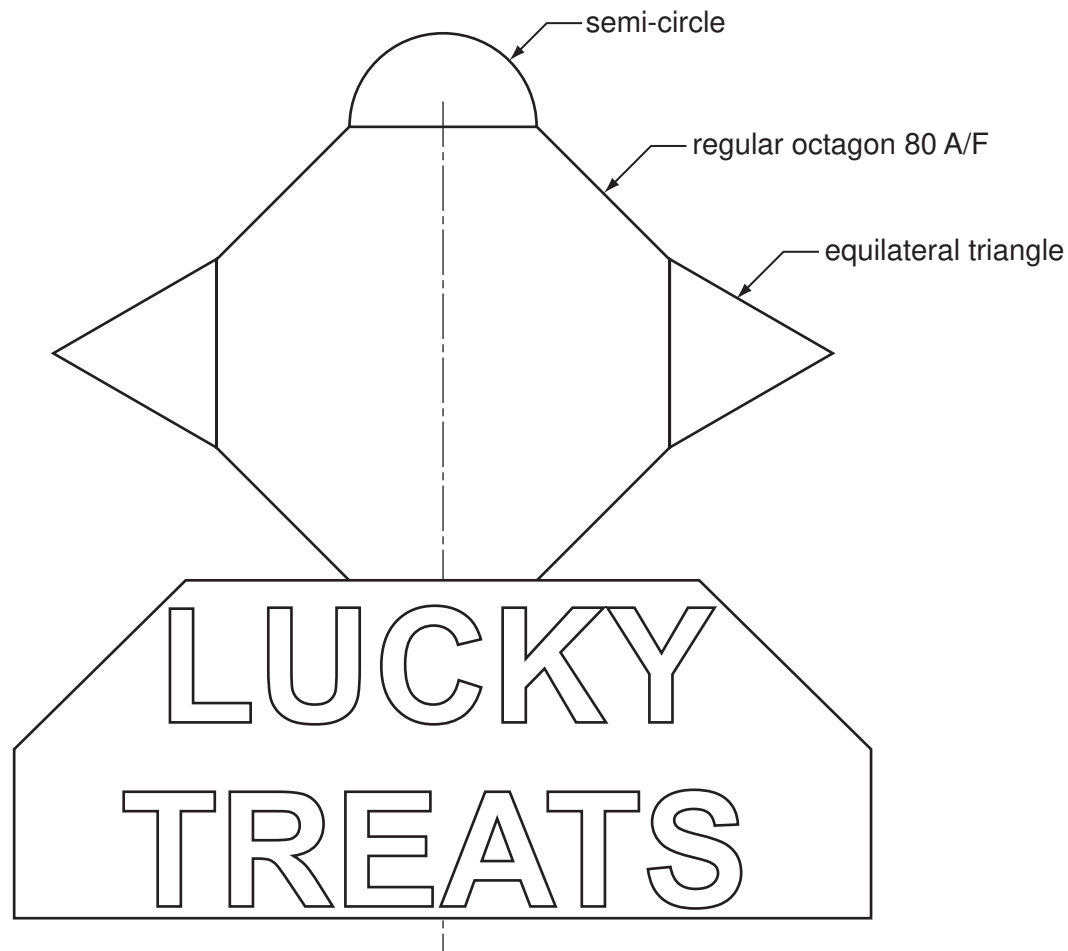

Complete the full size view of the signboard in the space provided to the right by drawing:

- (a) the regular octagon 80 A/F; [5]
- (b) a semi-circle on the top of the octagon; [1]
- (c) equilateral triangles on the sides of the octagon. [2]

Complete the signboard for LUCKY TREATS by:

- (a) adding the two remaining letters; [4]
- (b) drawing in the remaining parts of the outline. [3]

All the letters must be to the same height and style as those given.



For  
Examiner's  
use

**0445/21** May/June 2012 **1 hour**

© UCLES 2012

Centre Number .....

Candidate's Number .....

Candidate's Surname .....

Other Names .....

[Turn over]

www.PapaCambridge.com

**A3** A child-sized model of an ice-cream is used to attract customers to the shop.

Orthographic views of the ice-cream model are shown below. The model is made from expanded polystyrene.

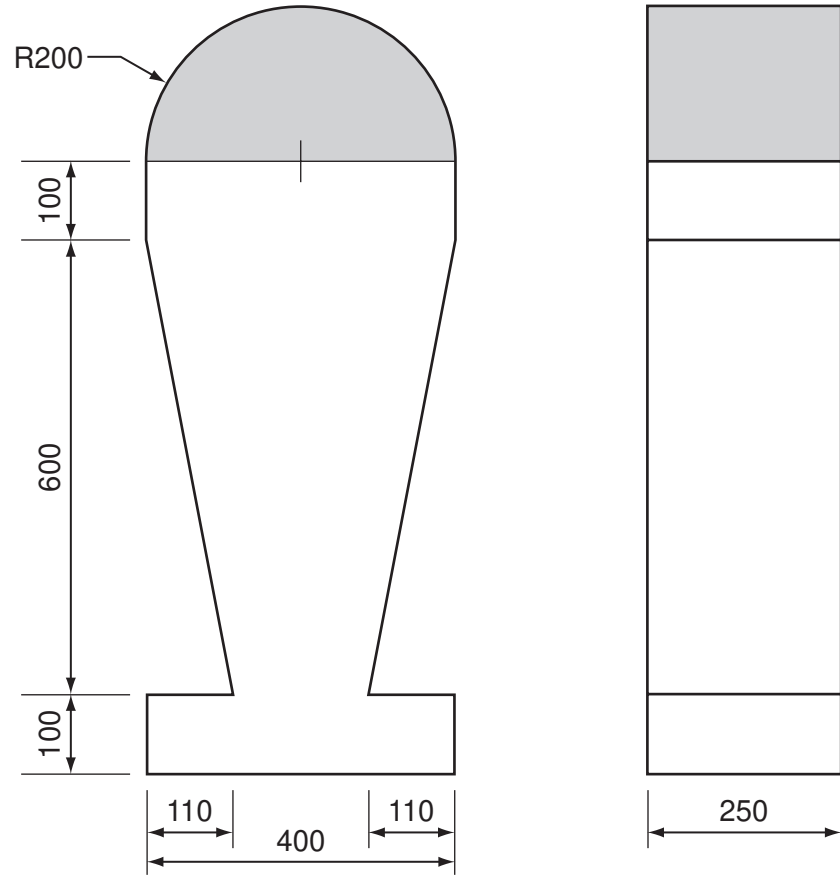

In the space to the right, draw an isometric view of the ice-cream model to a scale of 1:5. [10]

SCALE 1:5

**Section B**

Answer **either** question **B4** or **B5**.

**B4** The shop has a PYO (Pick Your Own) promotion for children.

A special box has been designed for children to fill with their selected sweets.

The outline drawing below shows the box fully assembled.

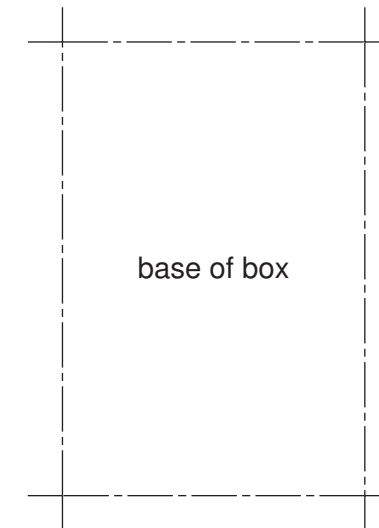
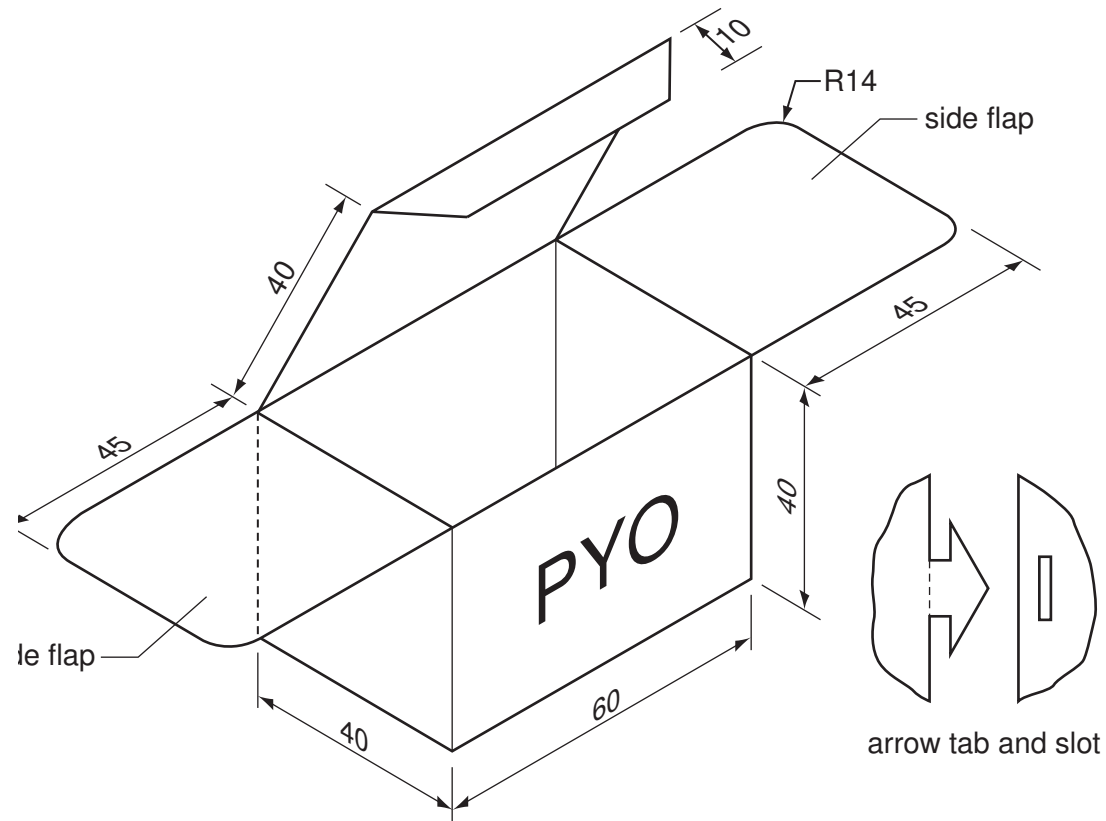

The box uses arrow tabs and slots to join the sides together.

- (a) In the space to the right, draw a full size, one-piece development (net) of the box. The base of the box has been drawn for you. [12]
  - (b) Add to the development (net) sufficient arrow tabs and slots to hold the sides together. [8]
  - (c) Write the letters PYO in the correct orientation on the correct face of your development (net). [3]
- (d) In the space below, draw a method of holding the side flaps together when folded inwards to close the box. Glue is not to be used. [2]

**B5 (a)** The quantities of flavoured ice-creams sold in the shop during the hottest week of the year in 2010 were as follows:

Vanilla	1200	Coconut	450
Chocolate	900	Coffee	150
Strawberry	600	Mint	300

In the space to the right, draw a pie chart to show the distribution of flavours as part of the total sales of ice-cream that week. [7]

**(b)** The seasonal sales for each of the products sold in the shop in 2010 are shown below in the data chart.

Shop sales 2010			
	Winter	Spring	Summer
chocolates	800	850	450
sweets	550	500	550
ice-cream	350	450	950
TOTAL	1700	1800	1950

In the space below, draw a bar chart to show the sales of ice-cream over the winter, spring and summer in 2010. [3]

**(c)** In the space below, draw a **three-dimensional** bar chart to show the difference in sales of all three products in the winter and the summer of 2010. [15]