

Section A

Answer **all** questions in this section.

A1 A new sports centre wants to attract local people to its facilities.

The logo and signboard for the sports centre are shown below.

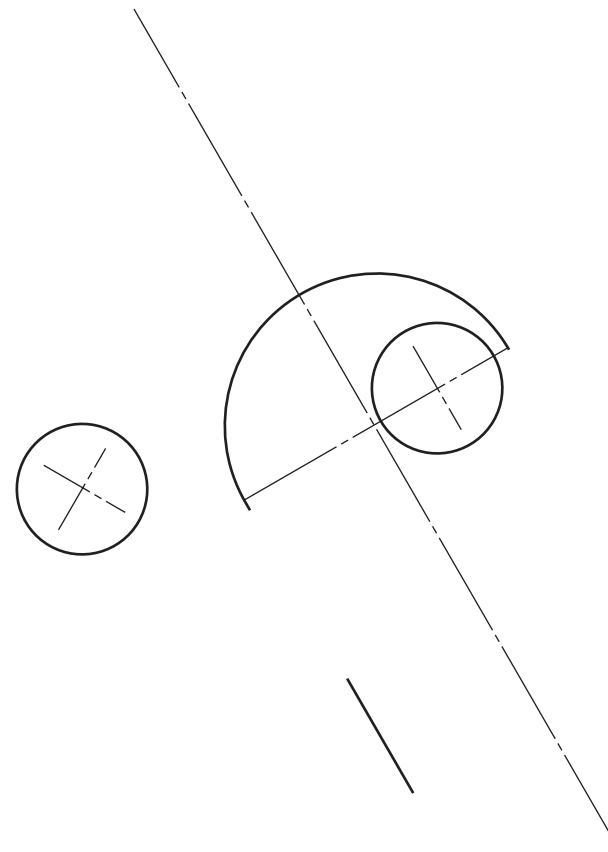
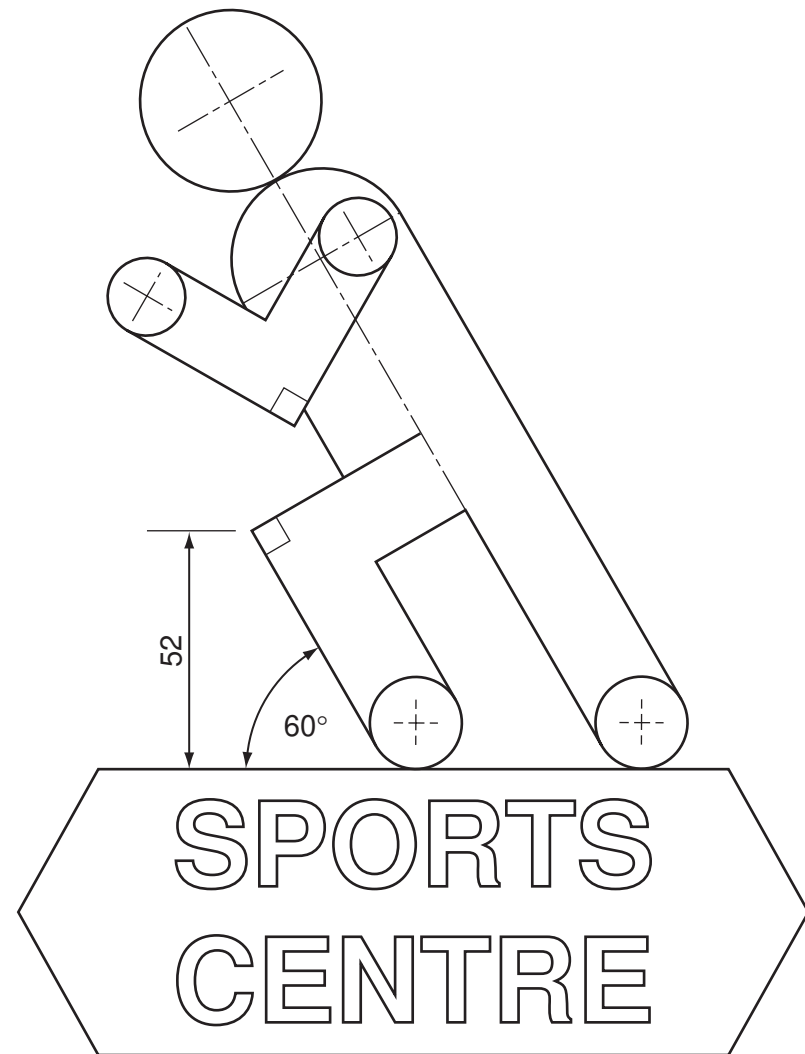

Complete the full size logo in the space provided to the right by drawing:

- (a) the $\text{Ø}40$ head; [2]
- (b) the arm connecting the shoulder to the hand; [3]
- (c) the front leg; [2]
- (d) the back leg. [2]

Complete the signboard for SPORTS CENTRE by:

- (a) adding the two remaining letters; [4]
- (b) drawing in the remaining parts of the border. [2]

All the letters must be to the same height and style as those given.

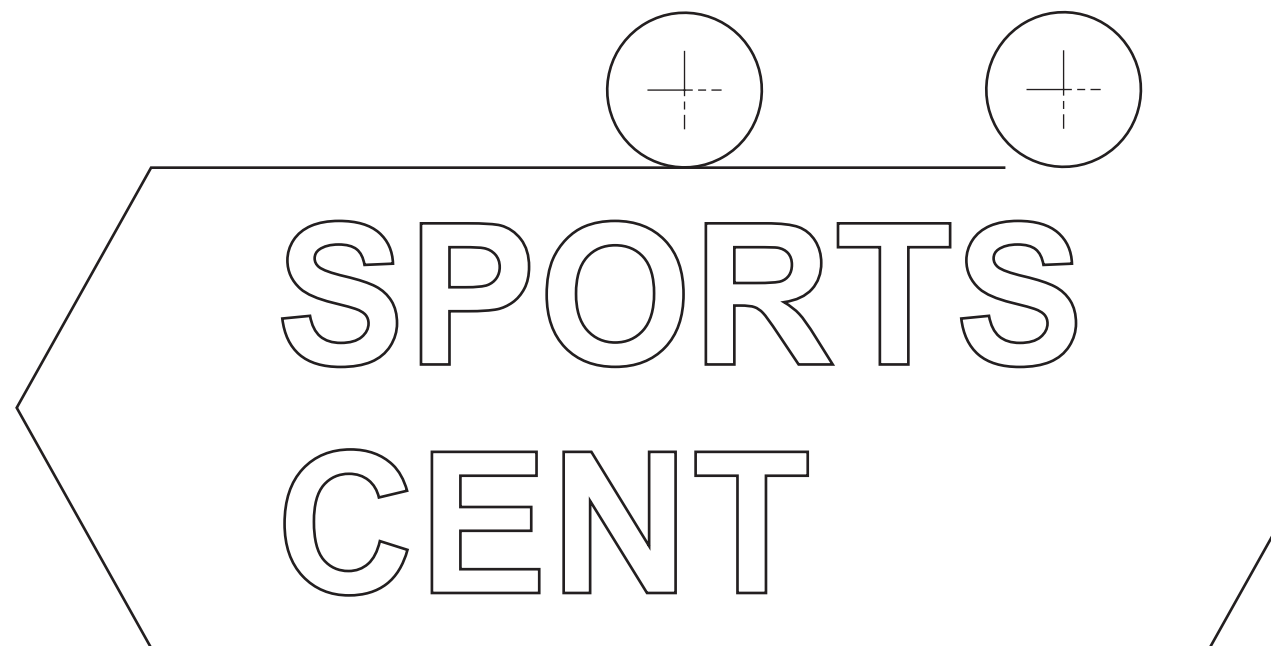

For
Examiner's
use

0445/23 May/June 2012 1 hour

© UCLES 2012

Centre Number

Candidate's Number

Candidate's Surname

Other Names

[Turn over]

A3 Orthographic views of a marker post for the start line of sprint races are shown below. The marker post is made from expanded polystyrene.

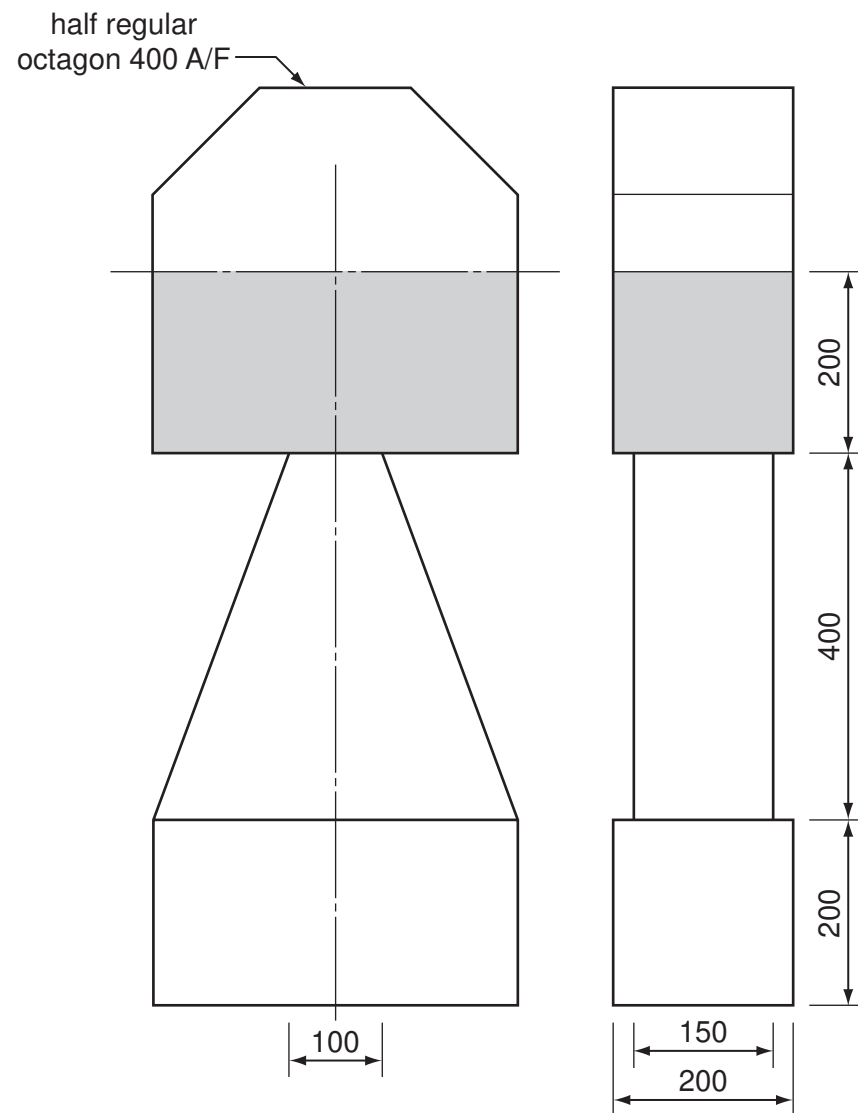

(a) In the space to the right, draw an isometric view of the marker post to a scale of 1:5. [9]

(b) Use pencil shading to highlight the shaded area as shown in the orthographic views. [1]

Isometric view of Marker Post

SCALE 1:5

Section B

Answer **either** question **B4** or **B5**.

B4 Competitors in athletic events are given drinking water in disposable paper cones.

Pictorial views of a carry tray made from 2 mm thick card and one paper drinking cone are shown below. Each tray is designed to hold two paper drinking cones. Each cone sits in a $\text{Ø}10$ hole in the base of the tray.

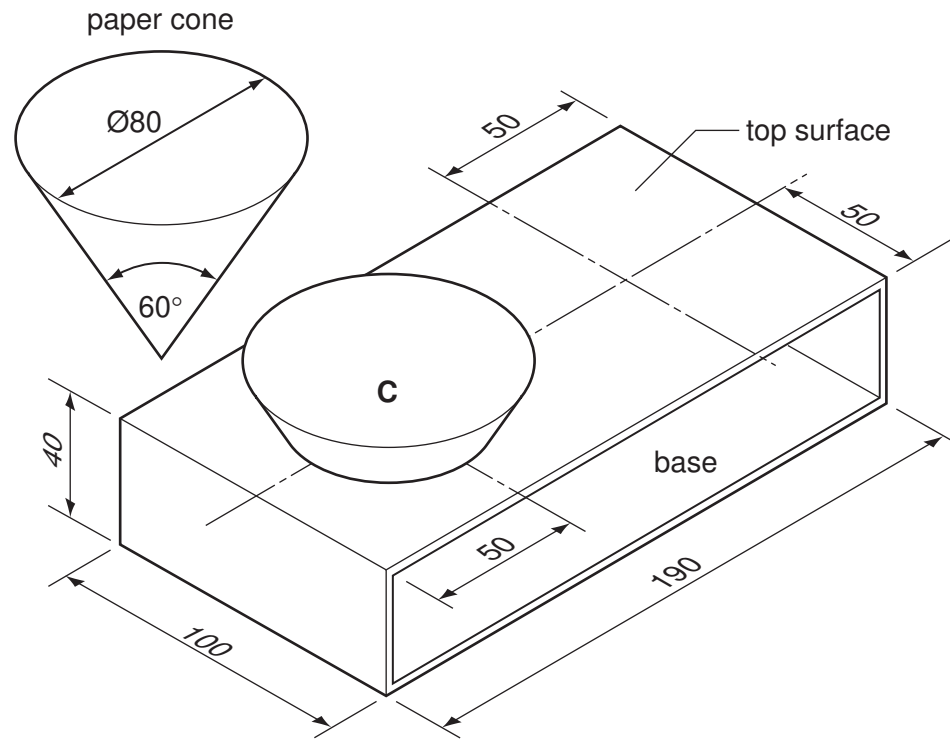

Draw full size in the space provided to the right:

- (a) a plan view and a front elevation of the card carry tray without the two holes; [5]
- (b) the centre positions of the two holes with drinking cone **C** in position on the plan view; [7]
- (c) drinking cone **C** in position on the front elevation; [9]
- (d) the correct size hole that is needed in the top surface of the carry tray to support the drinking cone in the one remaining position on the plan view. [4]

0445/23 May/June 2012 1 hour
© UCLES 2012

Centre Number

Candidate's Number

Candidate's Surname

Other Names

[Turn over]

B5 The sketch below shows a calendar desk tidy made from card. The card is pre-printed and sent out, as a development (net), to club members at the start of the athletic season.

Answer part **(a)** here

Answer part **(b)** here

- (a) Draw to a scale of 1:2 in first angle projection the PLAN and the end view (EV) of the assembled calendar desk tidy. The elliptical hole appears as a $\text{Ø}60$ circle in the PLAN. [10]
- (b) Complete to the same scale the one piece development (net) of the calendar desk tidy including the top and the elliptical hole. Do not include the base or glue tabs. Ignore the thickness of the card. [11]
- (c) Add the word 'JULY' to the correct face of the development. The word needs to be in a similar place to the other months. [4]

