



UNIVERSITY OF CAMBRIDGE INTERNATIONAL EXAMINATIONS
International General Certificate of Secondary Education

CANDIDATE
NAME

CENTRE
NUMBER

--	--	--	--	--

CANDIDATE
NUMBER

--	--	--	--



DESIGN AND TECHNOLOGY

0445/43

Paper 4 Systems and Control

May/June 2013

1 hour

Candidates answer on the Question Paper.

No Additional Materials are required.

To be taken together with Paper 1 in one session of 2 hours and 15 minutes.

READ THESE INSTRUCTIONS FIRST

Write your Centre number, candidate number and name on all the work you hand in.

Write in dark blue or black pen.

You may use a soft pencil for any diagrams or graphs.

Do not use staples, paper clips, highlighters, glue or correction fluid.

DO NOT WRITE IN ANY BARCODES.

You may use a calculator.

Section A

Answer **all** questions.

Section B

Answer **one** question.

At the end of the examination, fasten all your work securely together.

The number of marks is given in brackets [] at the end of each question or part question.

For Examiner's Use	
Section A	
Section B	
Total	

This document consists of an **17** printed pages and **3** blank pages.



Section A

Answer **all** questions in this section.

For
Examiner's
Use

- 1 Fig. 1 shows two circuit symbols.

Add the name of the component to each symbol.

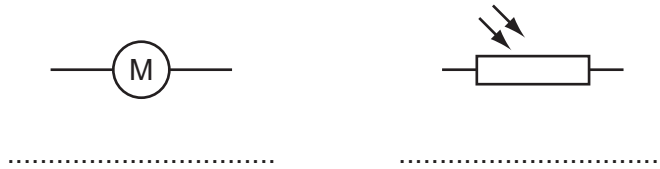

Fig. 1

[2]

- 2 Complete Fig. 2 to show how the two components can be connected to give a resistance of $5\text{ k}\Omega$ between points **A** and **B**.

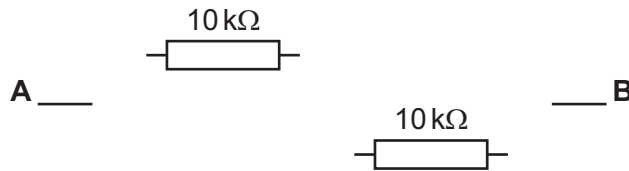

Fig. 2

[2]

- 3 (a) Name the switch arrangement shown in Fig. 3.

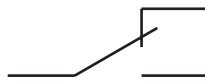

Fig. 3

.....

[1]

- (b) Add labels to Fig. 3 to indicate the normally closed (NC) and normally open (NO) terminals. [2]

- 4 Give **two** examples of natural structures that will resist tension.

1

2 [2]

- 5 Complete the table below by adding a tick (✓) to show which forces the materials are best at resisting. Only add **one** tick (✓) for each material.

materials	tension	compression	bending
concrete			
steel cable			
laminated wooden beam			

[3]

- 6 Fig. 4 shows the framework for a set of shelves used to carry heavy loads in a storage unit.

Use notes and sketches to show **two** methods of making the framework more rigid when the shelves are loaded.

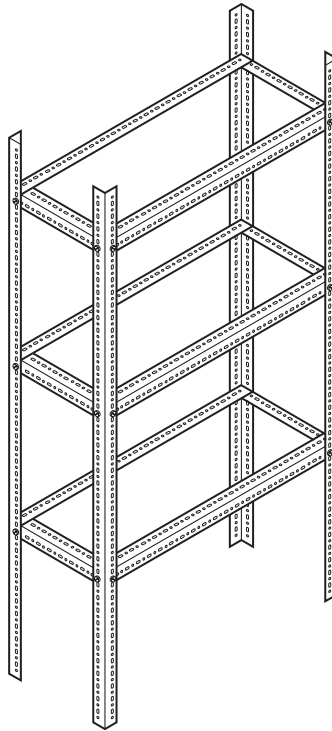

Fig. 4

[2]

- 7 Give **two** advantages of using roller bearings to support an axle compared to plain bearings.

1

2 [2]

8 (a) Fig. 5 shows a drawing of a cam.

Indicate the part of the cam that will provide 'dwell'.

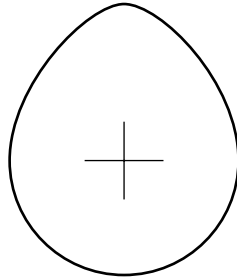

Fig. 5

[1]

(b) Describe the conversion of motion provided by a cam and follower.

.....

.....

[2]

9 Fig. 6 shows a crank lever, chain ring and pedal from a bicycle.

Add labels to show effort, load and fulcrum.

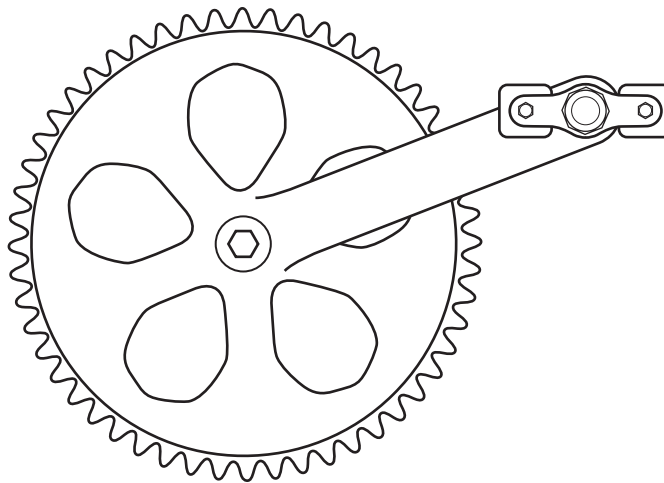

Fig. 6

[3]

10 Fig. 7 shows two views of a wheelbarrow loaded with bricks.

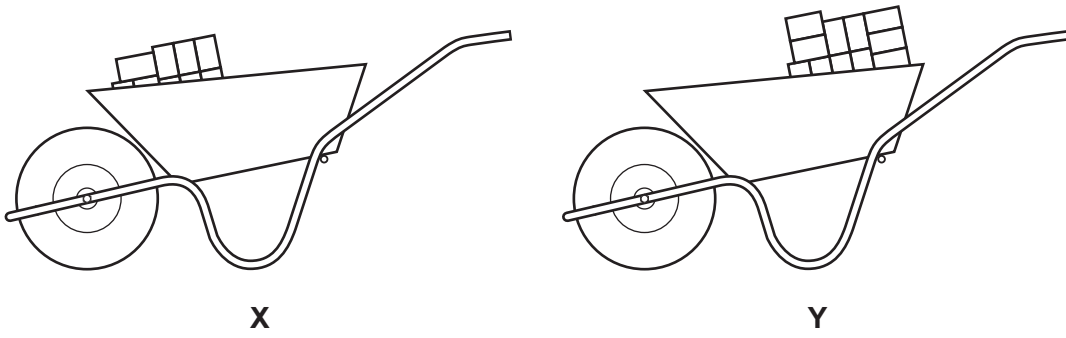

Fig. 7

(a) State the order (class) of lever which is used in a wheelbarrow.

..... [1]

(b) Explain why method X is a more efficient way of loading the wheelbarrow in Fig. 7 than method Y.

.....
.....
..... [2]

Section B

Answer **one** question from this section.

For
Examiner's
Use

11 (a) Fig. 8 shows a model beam set up for testing deflection.

Use notes and sketches to show how the deflection of the beam can be accurately measured.

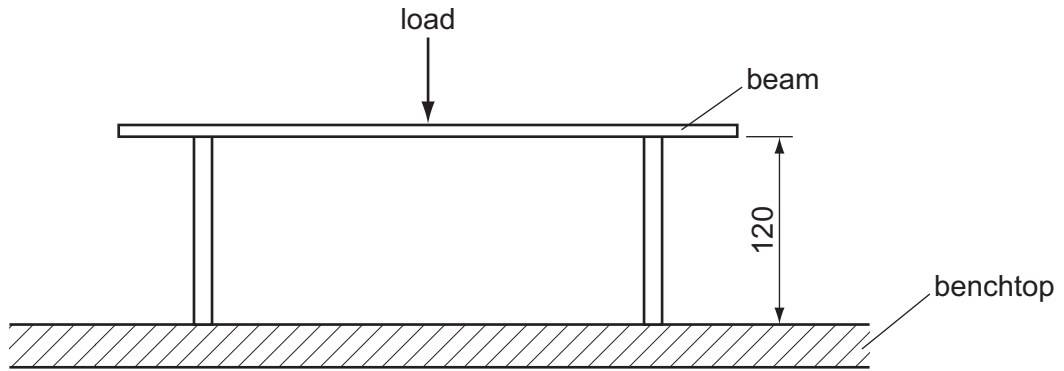

Fig. 8

[4]

(b) (i) Explain the term *factor of safety* with reference to structures.

.....
.....
.....
..... [3]

(ii) When a road bridge is being designed give **three** features that may be considered when calculating the factor of safety.

1
2
3 [3]

(c) Fig. 9 shows a bridge supporting the weight of a lorry.

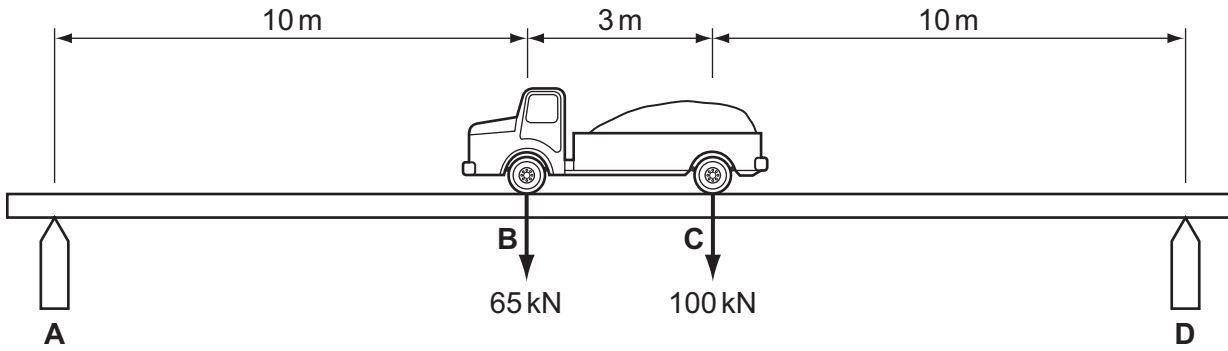

Fig. 9

Calculate the reactions at **A** and **D**.

.....

.....

.....

..... [4]

(d) Fig. 10 shows three different methods of joining metals used in a structure.

Give a different reason for using each method.

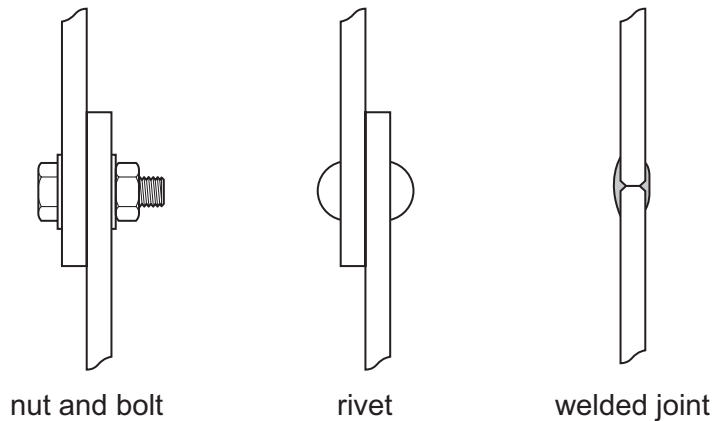

Fig. 10

nut and bolt

rivet

welded joint [3]

(e) (i) Wooden framing is often used in the construction of houses as shown in Fig. 11.

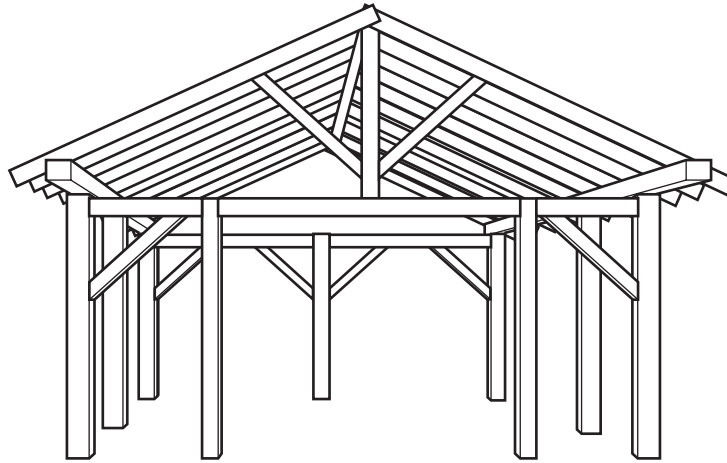

Fig. 11

Give **two** reasons why wood is a suitable material for a house framework.

1

2 [2]

(ii) Fig. 12 shows two lengths of wood to be used as floor beams.

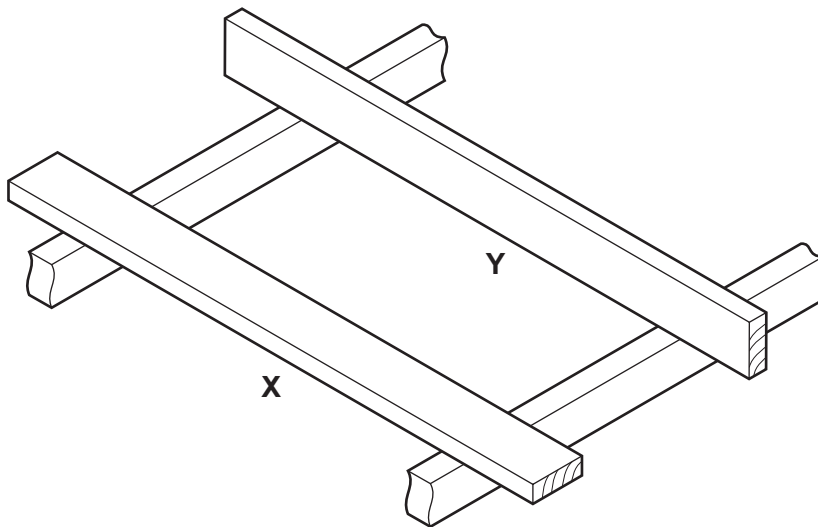

Fig. 12

Explain why the beam should be placed as shown in position **Y** rather than position **X**.

.....
..... [2]

(iii) Describe **two** defects in a length of wood that should be avoided when selecting the wood for use in a structure.

1

2 [2]

(f) Describe the difference between a strut and a tie in a framework.

.....

.....

..... [2]

12 (a) Fig. 13 shows two views of a car foot pump.



Fig. 13a

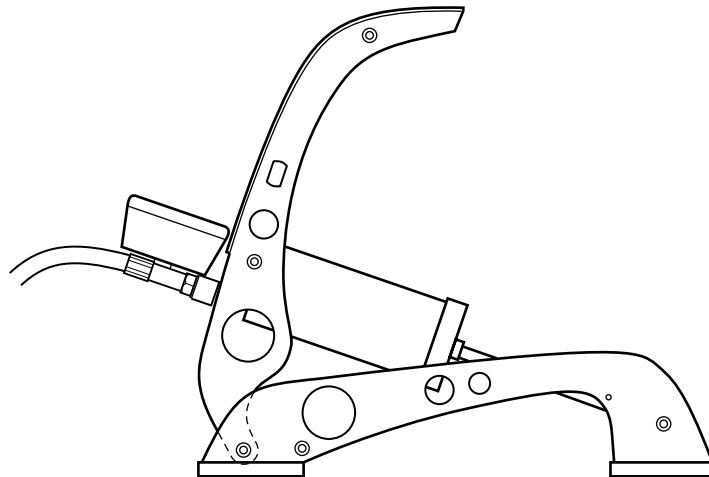

Fig. 13b

(i) Mark on Fig. 13b the position of **three** points that will pivot when the foot pump is operated. [3]

(ii) Give **one** reason for using grease rather than oil to lubricate the pivot points.
..... [1]

(iii) The action of the foot pump includes a conversion of motion.

Complete the sentence below.

..... motion is converted to motion when the foot pump is used. [2]

(iv) Explain why the actual Mechanical Advantage achieved by the foot pump is less than the calculated Mechanical Advantage.

.....
.....
..... [2]

(b) Fig. 14 shows the drive mechanism on a bicycle.



Fig. 14

(i) Give **two** reasons for using a chain drive rather than a belt drive to transmit motion on a bicycle.

1

.....

2

..... [2]

(ii) The bicycle has 3 chain rings and 8 sprockets at the rear wheel.

State the number of gear ratios available.

..... [1]

(iii) Calculate the Velocity Ratio when a 52 teeth chain ring and 18 teeth rear sprocket are used.

.....

..... [2]

(iv) Bearings are used on all of the moving parts of a bicycle.

Explain why ball bearings would be used on the chain ring axle.

.....

.....

..... [2]

(v)

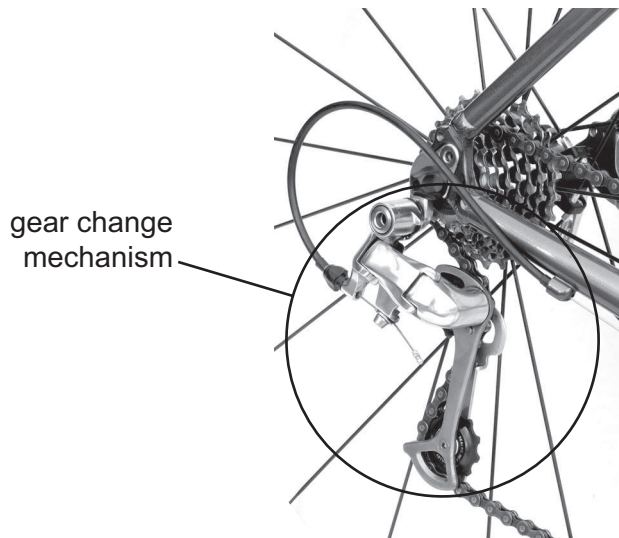

Fig. 15

State the **two** functions of the gear change mechanism shown in Fig. 15.

- 1
- 2 [2]

(c) (i) State **three** types of power source that can be used to operate a mechanism.

- 1
- 2
- 3 [3]

(ii) Explain how improving the design of a mechanism can reduce the energy required to operate the mechanism.

-
-
-
- [3]

- (d) Fig. 16 shows two views of a clamping device that uses a ratchet and pawl to hold the jaws closed. A release trigger will allow the clamp to open.

*For
Examiner's
Use*

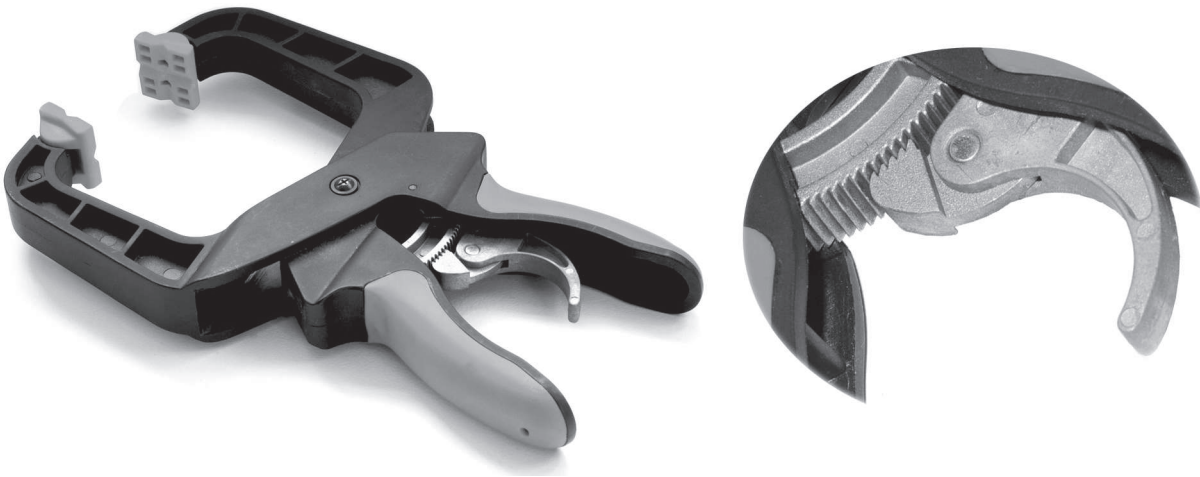

Fig. 16

Use notes and sketches to show **one** other use of a ratchet and pawl mechanism.

[2]

13 (a) When building a circuit the components have to be matched to their symbol or description.

(i) Complete Fig. 17 by matching the component to the symbol or description. One has been done for you.

1	relay
2	capacitor
3	
4	fixed resistor
5	

Fig. 17

[4]

(ii) The list below gives component values available for a time delay circuit.

capacitor values				
100 nF	2200 pF	470 μ F	100 μ F	330 nF

resistor values				
100 Ω	2 M Ω	270 k Ω	6.8 Ω	1.5 k Ω

State the values of the **two** components that will give the longest delay.

.....

..... [2]

(iii) When using an integrated circuit (IC) it is important to know the pin numbers.

Complete Fig. 18 to show the numbers of the two pins indicated on the 8 pin IC.

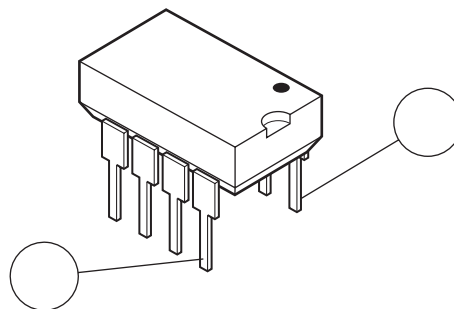

Fig. 18

[2]

- (b) A warning device is required to indicate when the temperature falls below a set level. The circuit shown in Fig. 19 is based on a 555 timer IC. When it has triggered, the warning LED will remain lit until the 555 timer resets.

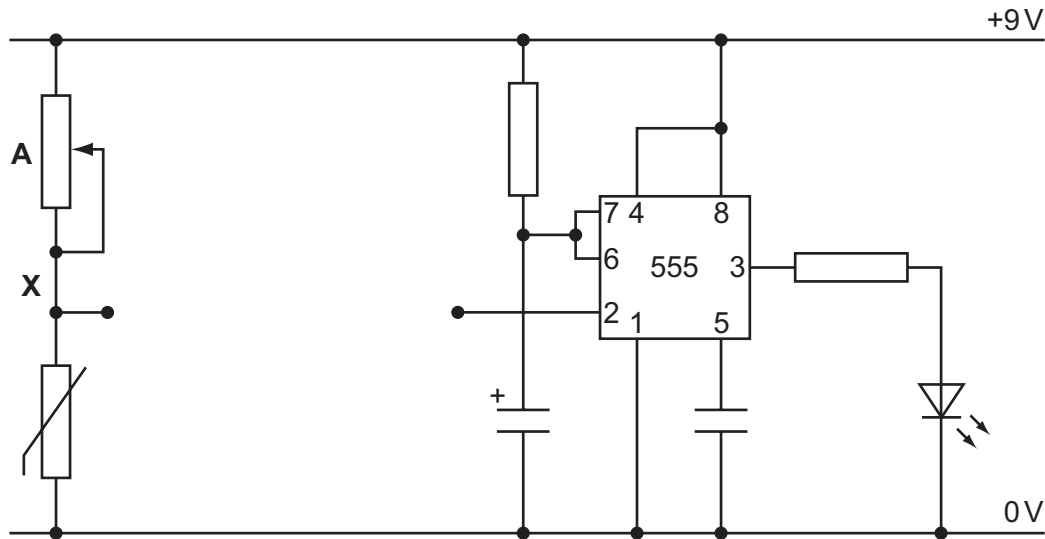

Fig. 19

- (i) Describe the purpose of component A.

..... [1]

- (ii) Calculate the voltage at point X when component A is set at 40 kΩ and the thermistor resistance is 3 kΩ.

Use the potential divider formula $V_{out} = \frac{R_2}{R_2 + R_1} \times V_{in}$

.....

 [2]

- (iii) A transistor switch is used between point X and pin 2 of the timer.

Complete the circuit in Fig. 19 to show the transistor switch connected. [3]

(c) When the circuit is built and tested, it triggers after 7 minutes 30 seconds and the LED remains on for 10 minutes.

(i) Complete Fig. 20 to show the graph of the 555 timer output.

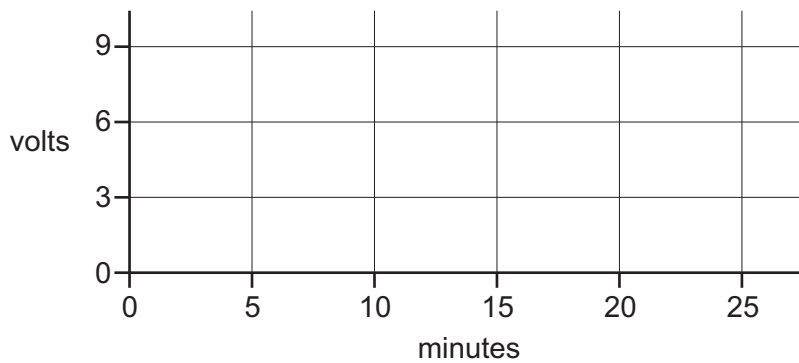

Fig. 20

[2]

(ii) The time for the LED to stay on had been calculated as 8 minutes.

Explain why the actual output time of 10 minutes does not match the calculated time.

.....
..... [2]

(d) A multimeter is to be used to measure the current flow in the circuit.

Complete Fig. 21 to show:

- the correct setting on the multimeter dial;
- the correct connections to the circuit and battery.

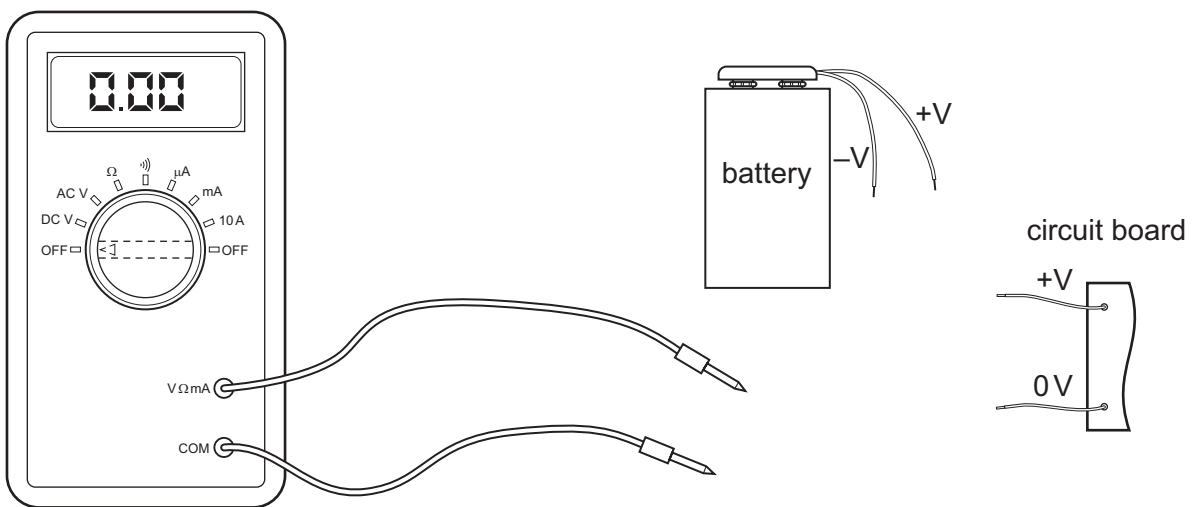
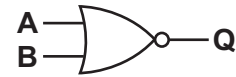
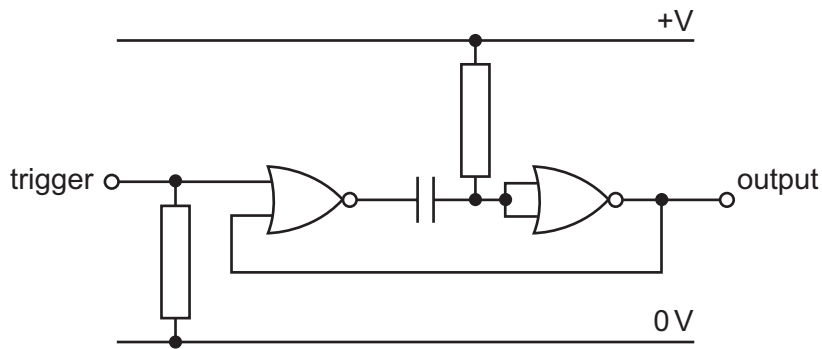

Fig. 21

[3]

(e) A circuit for a short time delay can be made from logic gates as shown in Fig. 22.

For
Examiner's
Use



A	B	Q
0	0	
0	1	
1	0	
1	1	

Fig. 22

(i) State the name of the logic gate used in the circuit.

..... [1]

(ii) Complete the truth table in Fig. 22 for the type of logic gate used.

[1]

(iii) One of the logic gates has both inputs joined.

Describe the effect of this on the output of the logic gate.

.....

 [2]

BLANK PAGE

Permission to reproduce items where third-party owned material protected by copyright is included has been sought and cleared where possible. Every reasonable effort has been made by the publisher (UCLES) to trace copyright holders, but if any items requiring clearance have unwittingly been included the publisher will be pleased to make amends at the earliest possible opportunity.

University of Cambridge International Examinations is part of the Cambridge Assessment Group. Cambridge Assessment is the brand name of University of Cambridge Local Examinations Syndicate (UCLES), which is itself a department of the University of Cambridge.