

Section B

Answer **either** question **B4** or **B5**.

Answer part **(a)** here

B4 The toy shop has 'magic crayons' for sale in blue, yellow, red and green.

Details of one crayon are shown below.

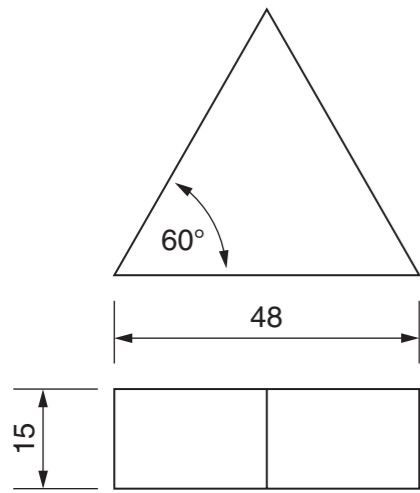

Four crayons shown arranged side by side.

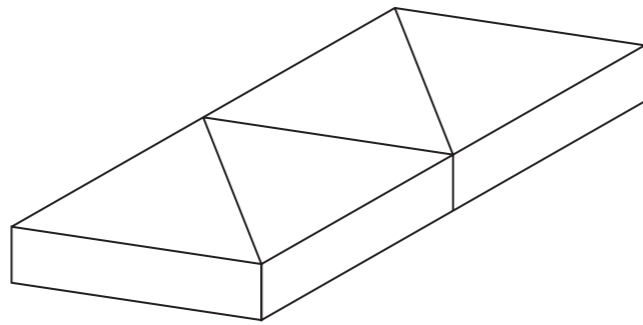

Each set of four crayons is packaged in a vacuum formed tray as shown in the section drawing below.

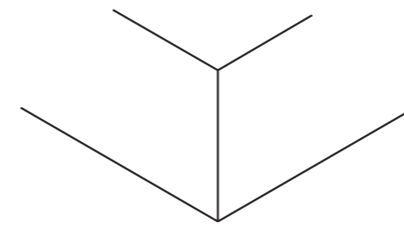
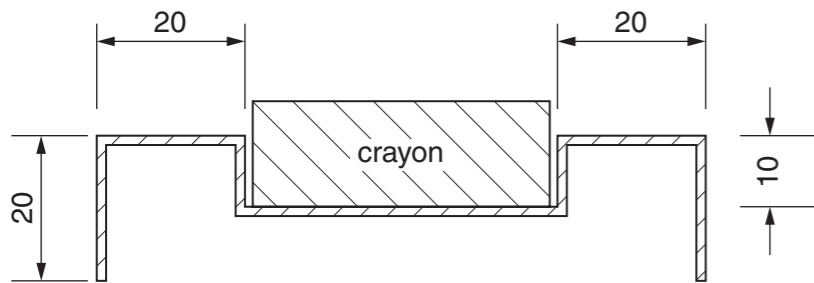

Answer part **(b)** here

- (a)** Draw full size, in the space provided, an isometric view of a vacuum formed tray that would store all four crayons side by side. Allow a minimum space of 20mm around the crayons. [9]
- (b)** Draw to a scale of 1:2, in the space provided, the one-piece development (net) of a card sleeve that would keep the crayons secure in the tray during storage. Include all glue tabs, a finger cut-out and one closed end of the tray. [16]

B5 The sketch below shows a pictorial view of a display stand for small toys. The display stand is made from two pieces of card. One piece is folded to make the sides and the second piece is folded to make the display surface.

Answer part **(b)** here

- (a)** Draw, to a scale of 1:2 in orthographic projection, an end of view of the assembled display stand in the direction of the arrow **E.V.** Include hidden detail. [8]
- (b)** Construct, to a scale of 1:2, a one-piece development (net) of the display stand sides in the space provided. Include a glue tab to join the sides into a regular hexagon. [12]
- (c)** Draw in the space provided, to a scale of 1:2, the display surface and supporting flaps before folding. [5]

Ignore the thickness of the card.

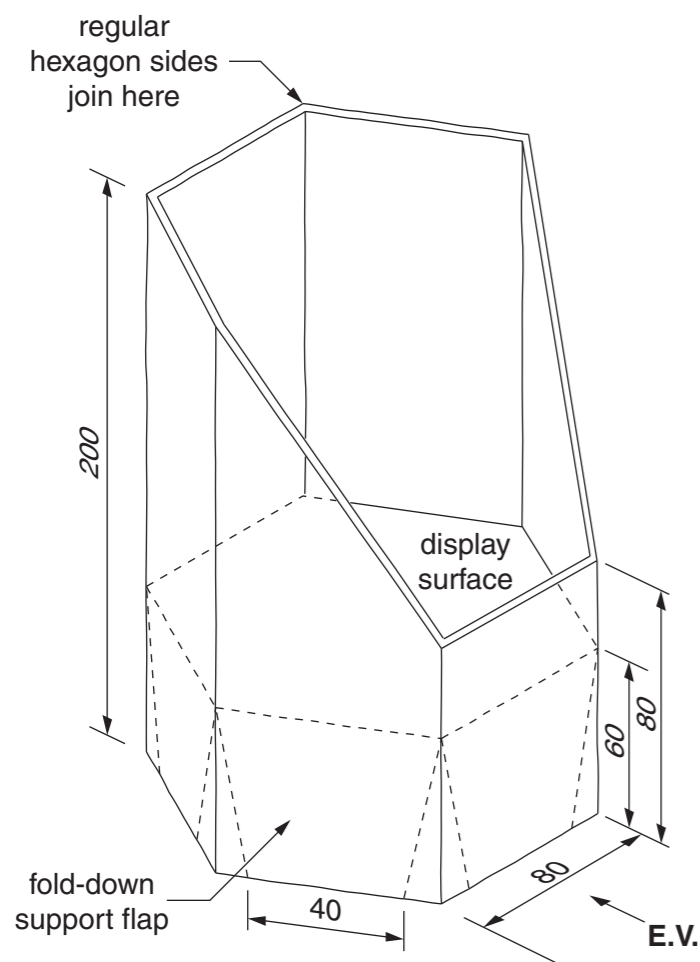

Answer part **(a)** here

Answer part **(c)** here