



UNIVERSITY OF CAMBRIDGE INTERNATIONAL EXAMINATIONS  
General Certificate of Education Advanced Level

**PSYCHOLOGY**

**9698/31**

Paper 3 The Specialist Choices

**October/November 2011**

**3 hours**

Additional Materials: Answer Booklet/Paper



**READ THESE INSTRUCTIONS FIRST**

If you have been given an Answer Booklet, follow the instructions on the front cover of the Booklet.

Write your Centre number, candidate number and name on all the work you hand in.

Write in dark blue or black pen.

Do not use staples, paper clips, highlighters, glue or correction fluid.

There is a choice of five specialist options in this question paper. Choose **two** options and answer questions from those two options only.

In each option there are **two** sections:

**Section A**

Answer **one** question for each of your chosen options.

**Section B**

Answer **one** question for each of your chosen options.

At the end of the examination, fasten all your work securely together.

The number of marks is given in brackets [ ] at the end of each question or part question.

This document consists of **11** printed pages and **1** blank page.



**PSYCHOLOGY AND EDUCATION**

Answer **one** question from Section A and **one** question from Section B.

**SECTION A**

Answer **one** question from this section.

- 1 (a) Explain, in your own words, what is meant by the term 'special educational need'. [2]
- (b) Describe **one** type of giftedness and **one** type of learning difficulty or disability. [6]
- (c) Describe **one** strategy for educating gifted children. [3]
- 2 (a) Explain, in your own words, what is meant by 'corrective strategy' for disruptive behaviour. [2]
- (b) Describe **one** type of disruptive behaviour and **one** cause for this type of disruptive behaviour. [6]
- (c) Describe **one** way in which a disruptive behaviour may be corrected. [3]

## SECTION B

Answer **one** question from this section.

3

### The testing teacher

I test out different meals to find out which tastes best,  
 My computer fails and I take it for a test.  
 My car is tested every year, it's safe without a doubt.  
 But my students sit so many tests, that I've worn them out!

- (a) Describe ways in which educational performance is assessed in schools. [8]
- (b) Evaluate ways in which educational performance is assessed in schools. [10]
- (c) Giving reasons for your answer, suggest how the educational abilities of children of different ages could be assessed. [6]

4

### Cross-perspectives

c o g n i t i v e	d	b e h a v i o u r i s t	d	d e v e l o p m e n t a l	p h y s i o l o g i c a l	d	h u m a n i s t	s o c i a l	d	differences
---	---	--	---	---	---	---	--------------------------------------	----------------------------	---	-------------

- (a) Describe how **one** psychological perspective has been applied to learning. [8]
- (b) Evaluate how **one** psychological perspective has been applied to learning. [10]
- (c) Giving reasons for your answer, suggest how **one** psychological perspective could be used to teach very young children. [6]

**PSYCHOLOGY AND ENVIRONMENT**

Answer **one** question from Section A and **one** question from Section B.

**SECTION A**

Answer **one** question from this section.

- 5 (a) Explain, in your own words, what is meant by the term 'climatological determinism'. [2]
- (b) Describe **two** studies showing the negative effects of climate and/or weather on performance. [6]
- (c) Suggest **one** way in which the negative effects of climate and/or weather on performance can be reduced. [3]
- 6 (a) Explain, in your own words, what is meant by 'psychological intervention before technological catastrophe'. [2]
- (b) Describe **one** natural disaster. [3]
- (c) Describe **one** way in which psychologists can help *before* a catastrophe and **one** way in which they can help *after*. [6]

## SECTION B

Answer **one** question from this section.

7

**Annoyance-ometer**

The intensity of sound is measured in units called decibels and is measured with a decibel meter. Noise is unwanted sound, and noise is annoying! But can the intensity of annoyance be measured?

- (a) Describe what psychologists have discovered about noise. [8]
- (b) Evaluate what psychologists have discovered about noise. [10]
- (c) Giving reasons for your answer, suggest ways in which positive sound, such as music, can be beneficial. [6]

8

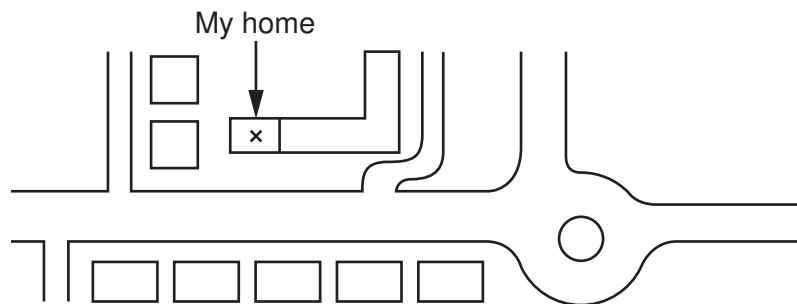
**Sketch map of my home**

- (a) Describe what psychologists have found out about environmental cognition. [8]
- (b) Evaluate what psychologists have found out about environmental cognition. [10]
- (c) Imagine you are required to design a 'you are here' map to help wayfinding. Giving reasons for your answer, suggest what important features your map would include. [6]

**PSYCHOLOGY AND HEALTH**

Answer **one** question from Section A and **one** question from Section B.

**SECTION A**

Answer **one** question from this section.

- 9** (a) Explain, in your own words, what is meant by 'sources of stress'. [2]
- (b) Describe **two** ways in which stress can be measured. [6]
- (c) Describe **one** way in which stress can be managed. [3]
- 10** (a) Explain, in your own words, what is meant by 'gender differences in health behaviour'. [2]
- (b) Describe **one** developmental difference and **one** gender difference in health behaviour. [6]
- (c) Describe **one** cultural difference in health behaviour. [3]

**SECTION B**

Answer **one** question from this section.

11

**Non-verbals**

Non-verbal communication (NVC) is as important as verbal communication in patient-practitioner relationships. But why do we have NVC?

- to assist speech
- as a replacement for speech
- to express attitude
- to show emotion

- (a) Describe what psychologists have learned about the patient-practitioner relationship. [8]
- (b) Evaluate what psychologists have learned about the patient-practitioner relationship. [10]
- (c) Using your psychological knowledge, suggest ways in which the patient-practitioner relationship can be improved. [6]

12

**What can we do?**

Haynes (2008) looked at ways to help people follow prescriptions for their medication. Counselling, written information and personal phone calls were helpful for short-term treatments. However, for long-term treatments, no simple intervention led to improvements in people taking their medicine.

- (a) Describe what psychologists have discovered about adherence to medical advice. [8]
- (b) Evaluate what psychologists have discovered about adherence to medical advice. [10]
- (c) Giving reasons for your answer, suggest ways in which a medical practitioner can measure adherence to medical advice. [6]

**PSYCHOLOGY AND ABNORMALITY**

Answer **one** question from Section A and **one** question from Section B.

**SECTION A**

Answer **one** question from this section.

- 13** (a) Explain, in your own words, what is meant by the term 'abnormality'. [2]
- (b) Describe **two** definitions of abnormality. [6]
- (c) Classify **one** abnormality of your choice. [3]
- 14** (a) Explain, in your own words, what is meant by 'reducing the effects of trauma'. [2]
- (b) Describe **two** types of trauma. [6]
- (c) Describe **one** way in which a type of trauma described in (b) may be reduced. [3]



**SECTION B**

Answer **one** question from this section.

15

**What am I?**

I've been around for at least six months.

I've disturbed my owner at work, in social relations and in self-care.

I've disorganised his speech and caused both hallucinations and delusions.

I'm not very pleasant at all.

- (a) Describe what psychologists have discovered about schizophrenia. [8]
- (b) Evaluate what psychologists have discovered about schizophrenia. [10]
- (c) You are a medical practitioner. Giving reasons for your answer, suggest how you would treat a person with schizophrenia. [6]

16

**The arsonists**

In a study of 83 abnormal need arsonists in the United States:

- 82% were white
- 94% were male
- 66% had average or above average intelligence
- 50% chose to stay and watch the fire burn.

- (a) Describe what psychologists have found out about abnormal avoidance and need. [8]
- (b) Evaluate what psychologists have found out about abnormal avoidance and need. [10]
- (c) Giving reasons for your answer, suggest how abnormal avoidance may be treated. [6]

**PSYCHOLOGY AND ORGANISATIONS**

Answer **one** question from Section A and **one** question from Section B.

**SECTION A**

Answer **one** question from this section.

- 17** (a) Explain, in your own words, what is meant by the human resource term 'reward systems'. [2]
- (b) Describe **two** reward systems. [6]
- (c) Outline **one** problem with a reward system. [3]
- 18** (a) Explain, in your own words, what is meant by 'physical conditions of work environments'. [2]
- (b) Briefly describe **two** physical conditions of a work environment. [6]
- (c) Describe **one** way in which the physical conditions of work environments could be improved. [3]

## SECTION B

Answer **one** question from this section.

19

**Would you get the job?**

Personality profile from Cattell's 16PF

Factor 1+		Factor 1–
1		1
2		2
3		3
4		4
5		5
6		6
7		7
8		8
9		9
10		10
11		11
12		12
13		13
14		14
15		15
16		16

- (a) Describe what psychologists have discovered about the selection of people for work. [8]
- (b) Evaluate what psychologists have discovered about the selection of people for work. [10]
- (c) Giving reasons for your answer, suggest what psychometric tests you, the personnel officer, would give to candidates applying for a job. [6]

20

**Mark Twain**

Mark Twain believed: "I can live for two months on a good compliment."

- (a) Describe what psychologists have discovered about motivation to work. [8]
- (b) Evaluate what psychologists have discovered about motivation to work. [10]
- (c) Using your psychological knowledge, suggest what the management of any company could do to motivate its employees through non-financial reward. [6]

