

|               |                  |      |
|---------------|------------------|------|
| Centre Number | Candidate Number | Name |
|---------------|------------------|------|

UNIVERSITY OF CAMBRIDGE INTERNATIONAL EXAMINATIONS  
International General Certificate of Secondary Education

**DESIGN AND TECHNOLOGY**

**0445/03**

Paper 3 Realisation

May/June 2005

**1 hour**

Candidates answer on the Question Paper.  
No Additional Materials are required.

**To be taken together with Paper 1 in one session of 2 hours 45 minutes.**

**READ THESE INSTRUCTIONS FIRST**

Write your Centre number, candidate number and name on all the work you hand in.  
Write in dark blue or black pen in the spaces provided on the Question Paper.  
You may use a soft pencil for any diagrams, graphs or rough working.  
Do not use staples, paper clips, highlighters, glue or correction fluid.

Answer **two** questions.

The number of marks is given in brackets [ ] at the end of each question or part question.

If you have been given a label, look at the details. If any details are incorrect or missing, please fill in your correct details in the space given at the top of this page.

Stick your personal label here, if provided.

| For Examiner's Use |  |
|--------------------|--|
| 1                  |  |
| 2                  |  |
| 3                  |  |
| 4                  |  |
| <b>TOTAL</b>       |  |

1 A child's toy is shown in Fig. 1.

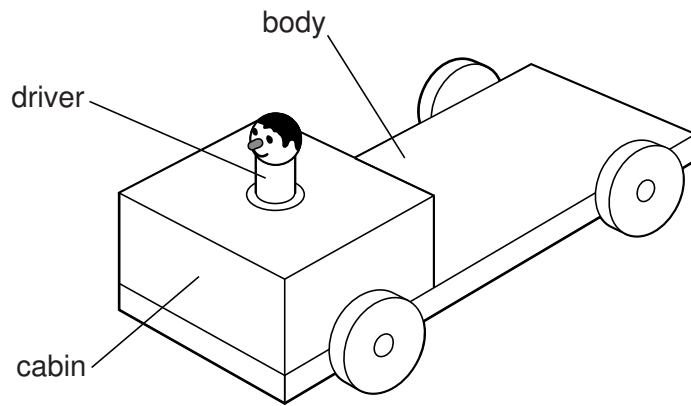

Fig. 1

(a) State **three** design features that could be added, or improvements that could be made, to make this toy more suitable for its intended use.

1. ....

2. ....

3. ....[3]

(b) Fig. 2 shows the basic design of the toy. As it is pulled and pushed along, the driver moves up and down.

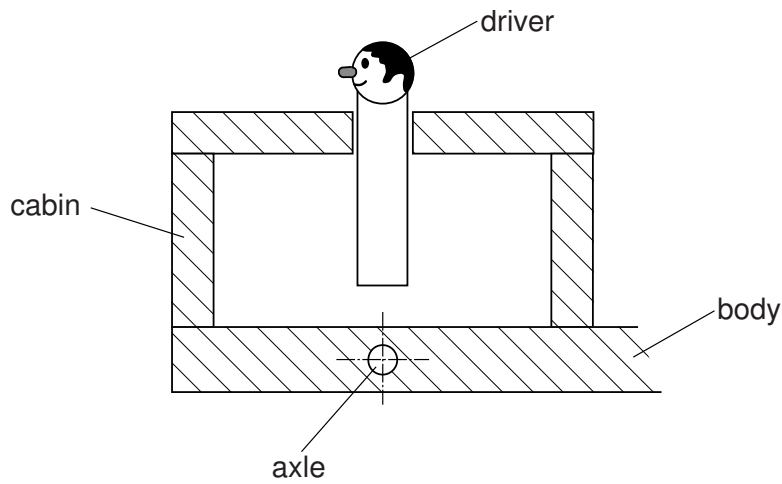

Fig. 2

- (i) On Fig. 2 draw a mechanism that will make the driver move up and down.
- (ii) Name the mechanism you have drawn in (i). .....[1]
- (iii) Give **one** reason for modelling the mechanism before making the toy.  
.....[2]

- (iv) Draw a mechanism that would make the driver rise slowly and fall rapidly when pulled along.

[3]

- (v) Name the mechanism you have drawn in (iv).  
.....[2]

- (vi) Give **one** disadvantage of using the type of mechanism drawn in (iv).  
.....[2]

- (c) Show, by means of sketches and brief notes, how the rear wheels could be attached to the axle, so that they may rotate freely. The wheels must not rub against the body.

[4]

(d) Complete the cutting list for the child's toy and specify the type of material to be

| part      | type of material | number required |
|-----------|------------------|-----------------|
| body      |                  |                 |
| cabin     |                  |                 |
| wheels    |                  |                 |
| axles     |                  |                 |
| driver    |                  |                 |
| mechanism |                  |                 |

[8]

(e) Give a reason for your choice of material for the wheels.

.....[1]

- 2 Fig. 3 shows a model bus shelter. It could be made using wood, veneers or brass sheets.

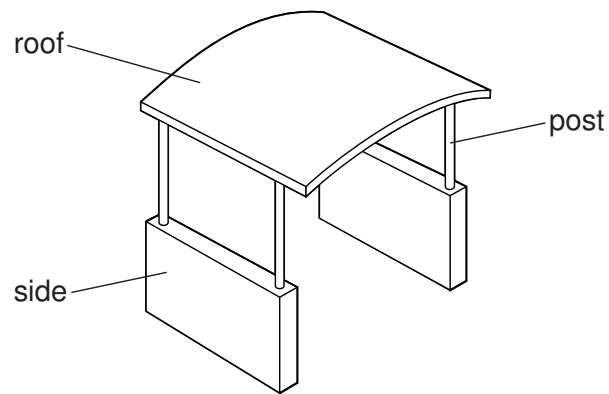

**Fig. 3**

- (a) Choose **one** material and use sketches and brief notes to describe:

(i) how to prepare the material for making the roof of the shelter;

[4]

(ii) any special tools such as jigs, formers and templates for making the roof;

[4]

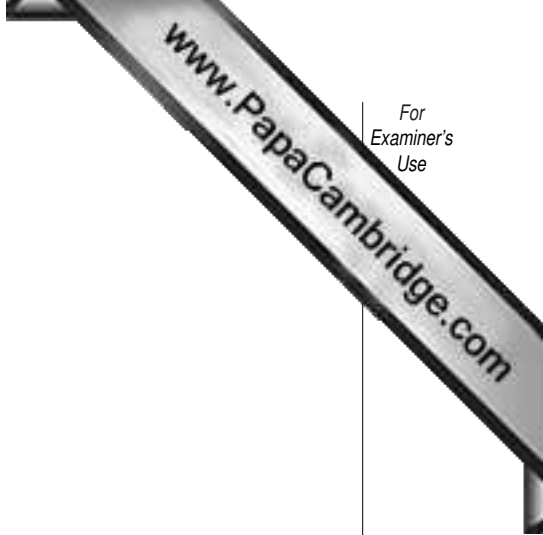

(iii) how to make the roof;

[3]

(iv) how to join the roof to the posts;

[3]

(v) how to join the posts to the sides.

[3]



(b) Use sketches and brief notes to describe how the material you have chosen was finished. Give details of the tools you would use.

[4]

(c) Explain each of the following terms and give an example of each.

(i) manufactured board .....

.....

example ..... [3]

(ii) non-ferrous .....

.....

example ..... [3]

(iii) hardwood .....

.....

example ..... [3]

3 An acrylic menu holder used in a restaurant is shown in Fig. 4.

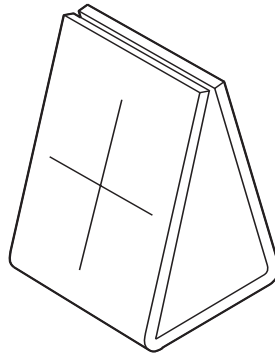

Fig. 4

(a) Name and sketch **two** tools you would use:

(i) when marking out acrylic;

1.....

[3]

2.....

[3]



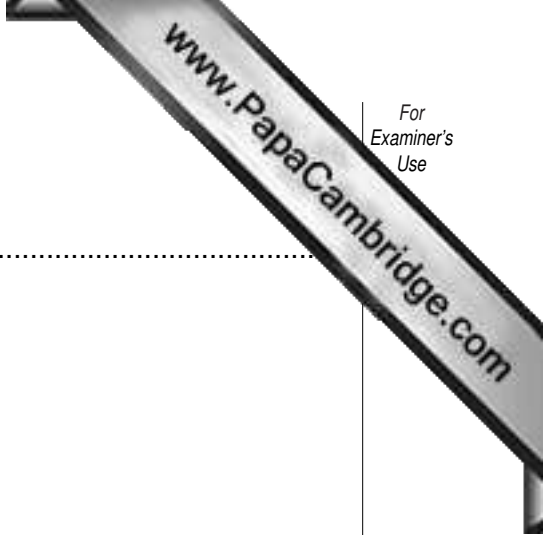

(ii) when cutting acrylic;

1.....

[3]

2.....

[3]

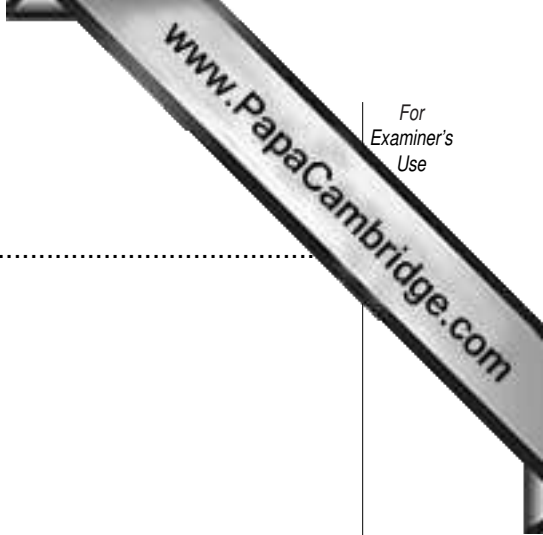

(iii) when finishing the edges of acrylic.

1.....

[3]

2.....

[3]

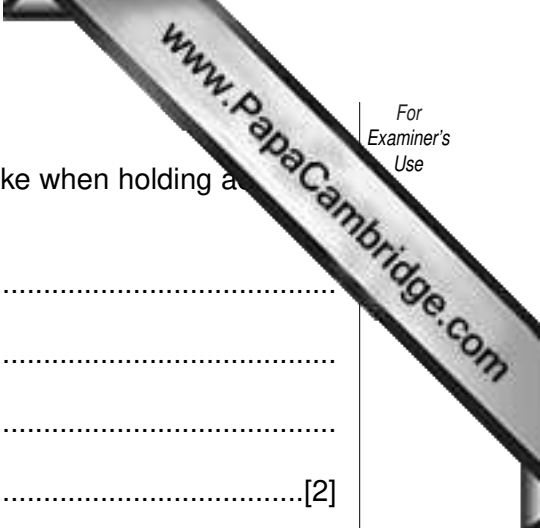

(b) Describe, and give a reason for, **one** precaution you would take when holding a  
a vice.

.....  
.....  
.....  
.....[2]

(c) Using notes and sketches, show how acrylic could be formed into the required shape for  
the menu holder.

[5]

(d) Suggest a method to make the base of the sign non-slip.

.....[1]

(e) (i) Explain the difference between thermoplastic and thermosetting plastics.

.....  
.....  
.....  
.....[2]

(ii) Give an example of:

1. a thermosetting plastic.....[1]

2. a thermoplastic .....[1]

4 A small metal gate is shown in Fig. 5.

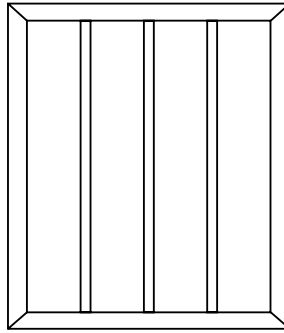

Fig. 5

(a) The **outer** frame is made from a square metal tube. Name a suitable metal.

.....[2]

(b) Give **one** reason why tube has been chosen.

.....  
.....[2]

(c) The frame has to be brazed together at the corners. Using notes and sketches, show how the material would be prepared and assembled ready for brazing.

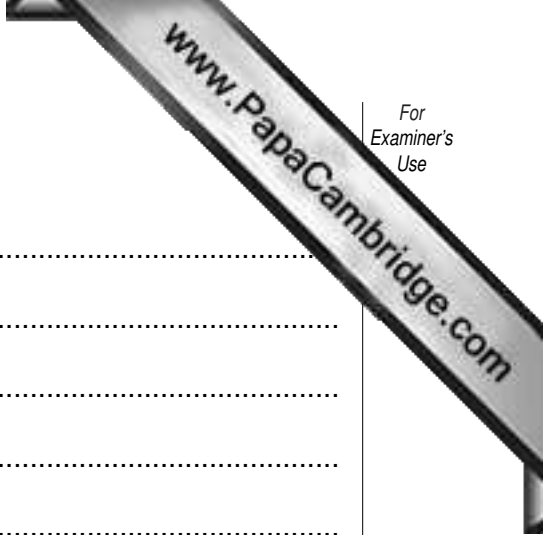

(d) Describe fully the following terms.

brazing .....

.....

flux .....

.....

oxidising .....

.....

spelter .....

.....[8]

(e) The rods forming the centre of the gate are held in the outer frame.  
Using notes and sketches show how this can be done. You must use a method other than brazing or welding.

- (f) The gate is to be hung on a metal post. Using notes and sketches design a method of hanging the gate so that it can be removed and replaced without the need for spanners or screwdriver.

