THINKING SKILLS

9694/11

Paper 1 Problem Solving

October/November 2016

1 hour 45 minutes

Additional Materials: Multiple Choice Answer Sheet
 Soft clean eraser
 Soft pencil (type B or HB is recommended)

* 9 0 0 2 1 5 2 1 7 7 *

READ THESE INSTRUCTIONS FIRST

Write your Centre number, candidate number and name on all the work you hand in.

There are **30** questions on this paper. Answer **all** the questions.

For each question there are four possible answers **A, B, C** and **D**. Choose the **one** you consider correct and record your choice in pencil on the separate answer sheet.

Read very carefully the instructions on the answer sheet. Ignore responses numbered 31 – 40 on the answer sheet.

DO **NOT** WRITE IN ANY BARCODES.

INFORMATION FOR CANDIDATES

Each correct answer will score one mark. A mark will not be deducted for a wrong answer.

This document consists of **18** printed pages and **2** blank pages.

- 1 The Waterborne Society holds an election annually to choose its President for the coming year. Ray Caravel was elected five consecutive times from 2006 to 2010, but didn't stand in 2011.

From 2011 to 2013 the same seven candidates stood, and on each occasion a different President was elected. The seven candidates and the number of votes they received were as follows:

<i>Candidate</i>	<i>2011</i>	<i>2012</i>	<i>2013</i>
Chad Barque	38	51	45
Doris Coble	71	62	47
Lance Ketch	74	55	38
Olive Punt	36	53	78
Jack Raft	59	46	59
Conner Sloop	34	66	62
Coral Wherry	55	49	42

Which candidate finished in the same position in all three elections from 2011 to 2013?

- A Chad Barque
 B Doris Coble
 C Jack Raft
 D Coral Wherry
- 2 This is the floor of a room in my house. It is covered with square tiles.

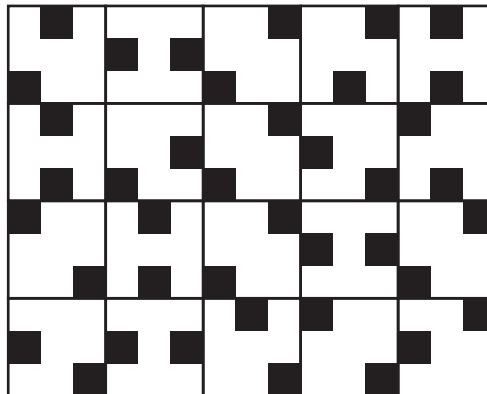

How many different patterns are there on the individual tiles?

- A 3
 B 4
 C 5
 D 6

- 3 Terry is preparing to make a presentation in a meeting. He has produced a slide show, but also wants to give out booklets to all of the participants. Each booklet will be made from sheets of A4 paper. Each sheet of paper can have a page of the booklet printed on each side. The booklet will have a total of 37 printed pages. There will be 20 people in the meeting.

How many sheets of paper will be required to make the booklets?

- A 370
- B 380
- C 740
- D 760

- 4 Jean-Pierre saved up for 8 months to buy a \$1000 gold chain. The table shows how much he saved in each of seven months. By the end of December, Jean-Pierre had exactly enough money saved to buy the chain.

<i>May</i>	<i>June</i>	<i>July</i>	<i>August</i>	<i>September</i>	<i>October</i>	<i>November</i>
\$150	\$125	\$175	\$125	\$50	\$150	\$100

Which of these bar charts, if the axes were suitably labelled, could represent how much Jean-Pierre saved each month?

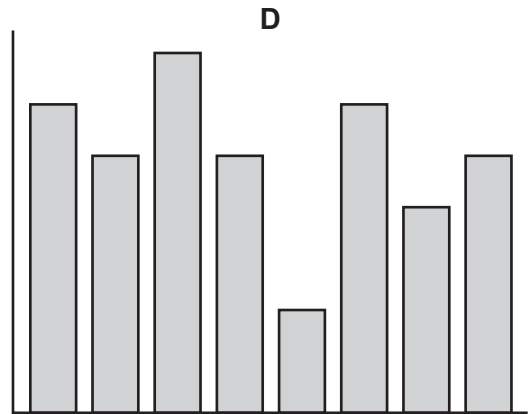
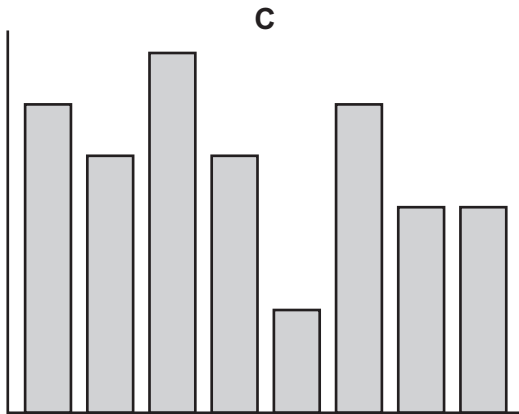
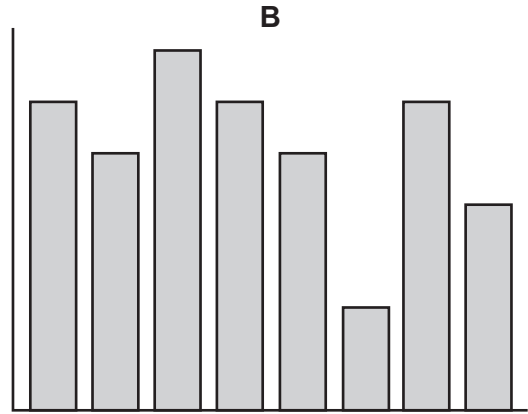
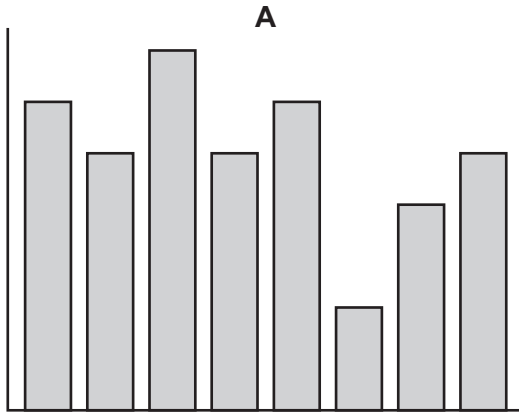

- 5 My grandchildren, Domenico and Pedro, never visit me on a Monday, but do visit at least 5 and sometimes 6 times each week. Domenico eats 2 fairy cakes per visit, sometimes 3. Pedro always eats 4 fairy cakes per visit. It is Monday today, and I only have 12 fairy cakes in my house.

How many fairy cakes must I buy in order to make sure that I do not run out of them during the coming two weeks?

- A 30
 B 60
 C 72
 D 84
- 6 The Footietown soccer squad is playing in a tournament in Sportsville. There are 30 people in the squad. In order to travel to Sportsville, the squad decide to hire transport from a particular company. The vehicles that are available, the total number of people that a particular vehicle can carry and the hire costs are given in the following table.

<i>Type of vehicle</i>	<i>Number of people</i>	<i>Hire cost</i>
Car	4	\$22
People-carrier	7	\$32
Minibus	13	\$68

To improve its carbon footprint, the company offers a discount of \$6 if fewer than 6 vehicles are used to transport 30 people. Large numbers of each type of vehicle are available.

What is the minimum cost of vehicle hire for this journey?

- A \$144
 B \$146
 C \$148
 D \$152

- 7 A jeweller sells rings online and the table below shows his prices, each based on the value of the gold and the single gemstone which is set in it. Mrs Jamset must buy a ring for each of her three daughters. Each girl's ring must contain at least 3.5 g of gold and the three gemstones must be of different colours.

Gemstone	Choice of colours	Price of ring by weight of gold			
		1.0–1.9 g	2.0–2.9 g	3.0–3.9 g	4.0–4.9 g
Pearl	black or white	\$30	\$60	\$100	\$120
Sapphire	blue	\$45	\$90	\$150	\$180
Garnet	red	\$40	\$80	\$125	\$150
Emerald	green	\$150	\$400	\$500	\$600
Citrine	yellow	\$25	\$50	\$80	\$100
Ruby	pink or red	\$90	\$180	\$300	\$360

What is the cheapest price that Mrs Jamset could pay for the three rings?

- A \$170
- B \$190
- C \$280
- D \$305

- 8 This is a picture of my birthday cake. The three sections are coloured red (outside), white and blue (centre).

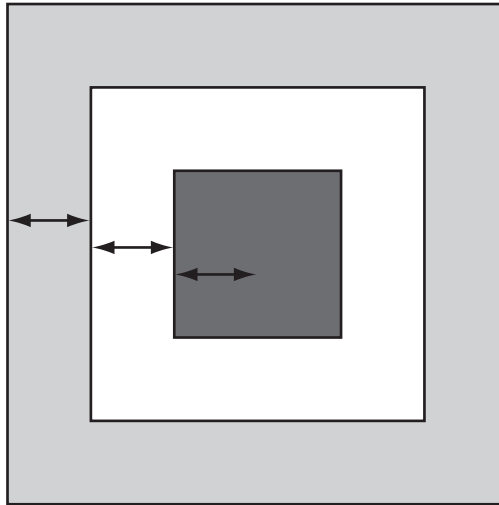

The widths of the three sections (shown by the arrows) are the same.

What percentage of the area is red?

- A 33%
 - B 50%
 - C 56%
 - D 64%
- 9 The car I have recently bought has 1108km showing on the odometer (distance travelled). I notice that the time on the car's clock is 11.15am. I have a bet with myself that in exactly 15 minutes' time both instruments will read the same – 1 1 3 0.

What average speed, to the nearest km/h, will I have to maintain to win my private bet?

- A 41 km/h
- B 68 km/h
- C 88 km/h
- D 147 km/h

- 10 The diagram shows the vertical cross-section of a barrel.

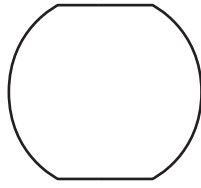

Water flows into the barrel at a constant rate until it is full. An observer records the height of the water in the barrel at regular intervals and draws a graph of the results.

Which of the following graphs best represents the observer's graph?

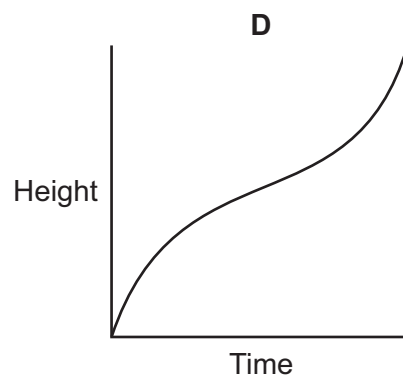
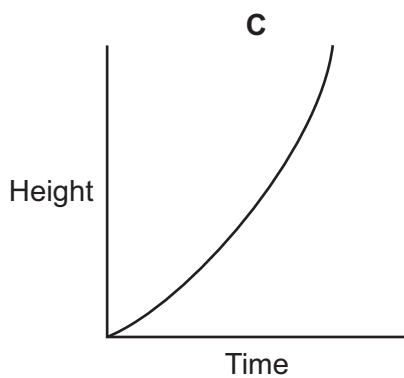
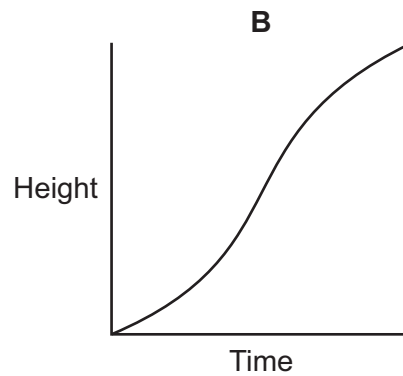
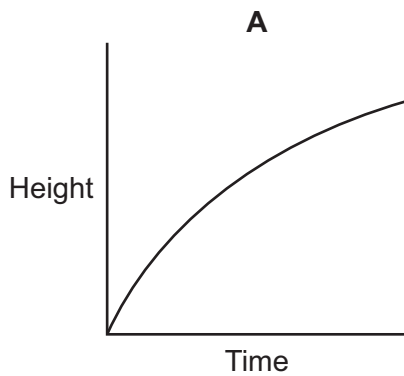

- 11 A charity is selling tickets which may win prizes. The tickets all have 3 digits, from 001 to 999. A prizewinning ticket has the first two numbers adding to give the third, e.g. 246.

How many winning tickets are there?

- A** 45
- B** 54
- C** 63
- D** 90

- 12 James regularly drives from his house to the local shops, parks his car to do his shopping and then drives home again. His journey is a distance of 20 km in total and it costs him 150¢ per km for petrol. He usually parks for 6 hours and pays 120¢ per hour for parking.

The cost of both petrol and parking are going to increase, but James wishes to keep the overall cost the same and so plans to reduce his stay to 4 hours.

Which of the following increases in prices could explain this?

- A Petrol increases by 4¢ per km and parking increases by 30¢ an hour
 - B Petrol increases by 4¢ per km and parking increases by 40¢ an hour
 - C Petrol increases by 5¢ per km and parking increases by 30¢ an hour
 - D Petrol increases by 6¢ per km and parking increases by 20¢ an hour
- 13 As part of the Hybrow Arts Festival, the Arbuthnott Theatre Company will give 6 performances of a short play entitled *Think Again* next Saturday. The first performance will begin at 15:00, and the last at 19:30. There will be a break of 20 minutes between performances, except between the third and fourth, when the break will be 70 minutes.

How long will each performance of *Think Again* last?

- A 20 minutes
 - B 24 minutes
 - C 28 minutes
 - D 34 minutes
- 14 Abrar knows that he needs 27 litres of wood preservative to cover his garden fences. He can buy it in tins of different volumes. The prices of these tins are shown in the table below.

Volume (litres)	1	5	8	15	20
Price (\$)	6	20	30	55	72

How many tins should Abrar buy, to get at least the 27 litres he needs at the least possible cost?

- A 2
- B 3
- C 4
- D 5

15 The honeycomb structure below is constructed by joining a number of hexagonal blocks together.

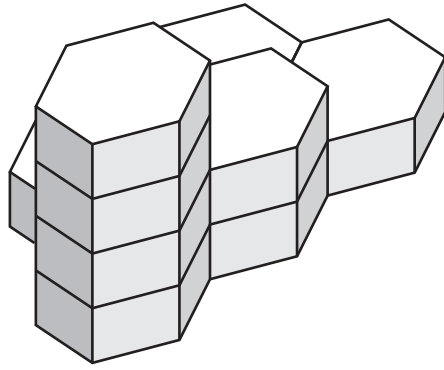

Which of the plan views below is a true representation of the 3-dimensional honeycomb structure, as seen from above?

A

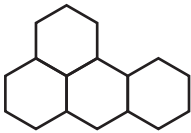

B

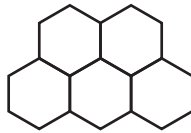

C

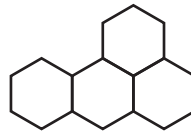

D



- 16** Energy Ratings can be used to choose food based on the concentration of calories. The table below shows a range of foods along with their Energy Rating, which is the number of grams of the food which provides one Calorie of energy. It also shows the portions of these foods, in grams, that Marcello has in his lunch.

<i>Food</i>	<i>Energy Rating</i> (grams/Calorie)	<i>Marcello's lunch</i> (grams)
Celery	7.125	50
Peppers	3.7	40
Apples	1.925	50
Turkey	1.02	150
Doughnut	0.26	50
Potato Chips	0.185	100

Which of the following graphs represents the number of Calories in each of Marcello's portions of food?

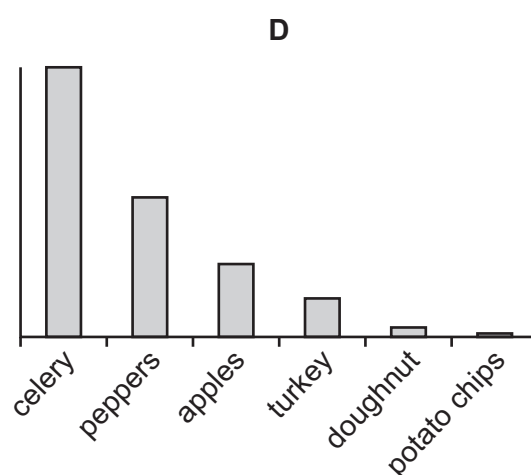
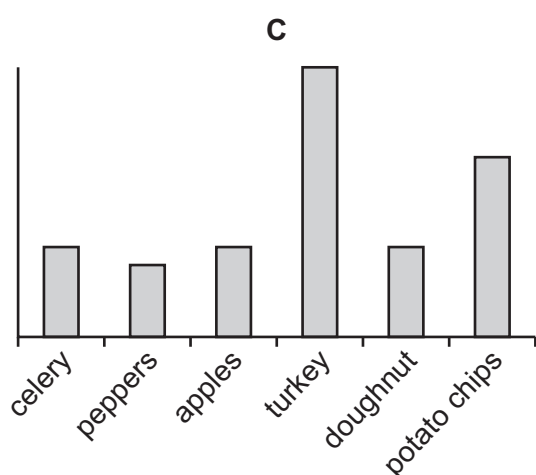
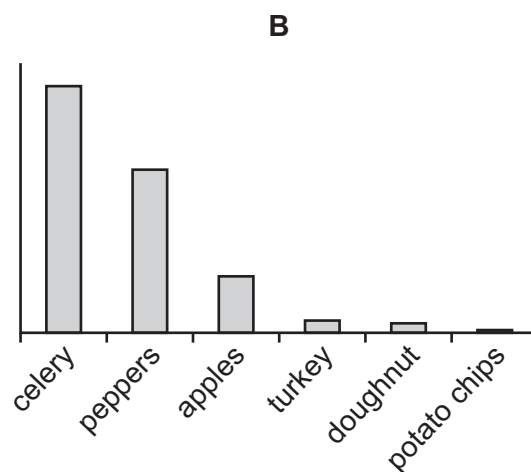
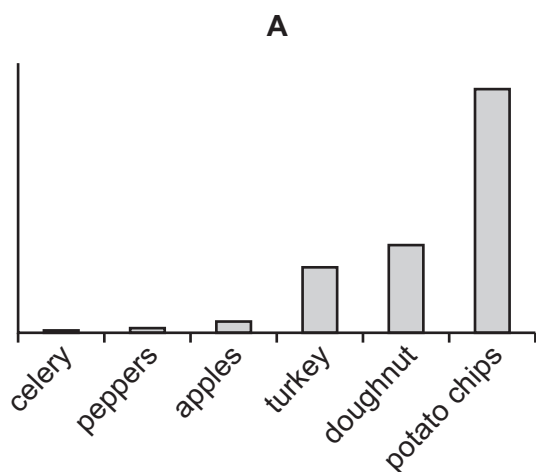

- 17 Freda wants to buy a particular type of lawnmower. She wants the engine power to be at least 1200 watts and the cutting width to be at most 30cm. She also wants the lawnmower to come ready-assembled and to be delivered to her home. The following table shows the costs from four local gardening supplies stores.

<i>Store</i>	<i>Engine power (watts)</i>	<i>Cutting width (cm)</i>	<i>Ready-assembled?</i>	<i>Basic cost</i>	<i>Discount on basic cost</i>	<i>Delivery charge</i>
Alfies	900	25	Yes	\$110	None	None
B and T	1200	30	Yes	\$120	10% on Wednesdays	\$10
Cutters	1300	30	No	\$109	None	\$10
Daves	1250	25	Yes	\$135	\$15 except on Saturdays	None

Freda can only go to the store to buy the lawnmower on Wednesday next week.

Which store should Freda choose so that she pays the least possible amount for the lawnmower that she wants?

- A** Alfies
- B** B and T
- C** Cutters
- D** Daves

- 18 This is a plan view of my garden. The overall shape is rectangular, as are the shed and the flower bed.

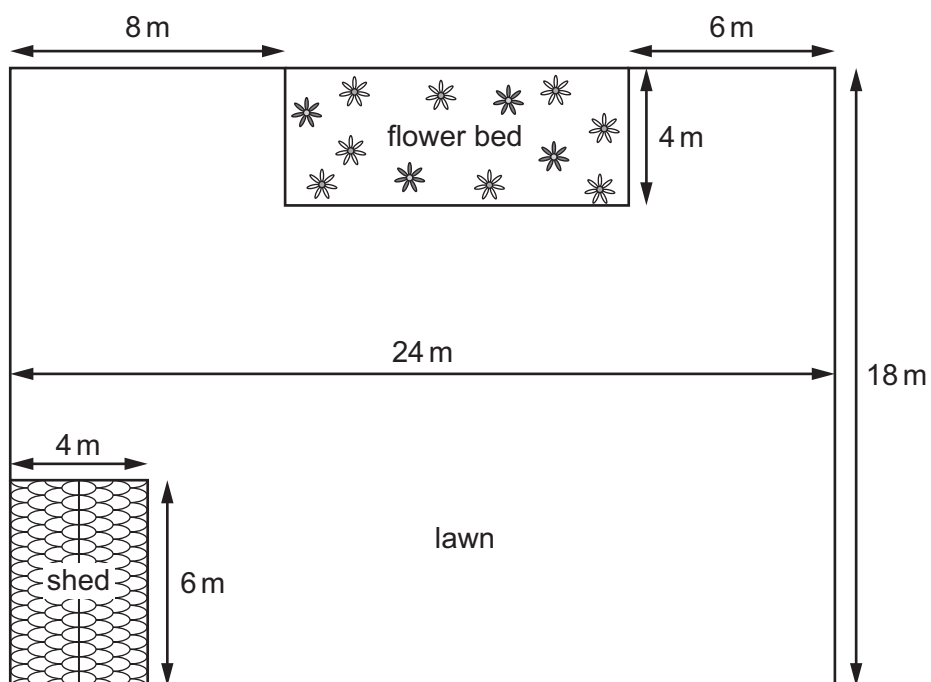

Which of the following gardens has a lawn that is exactly the same shape as mine?

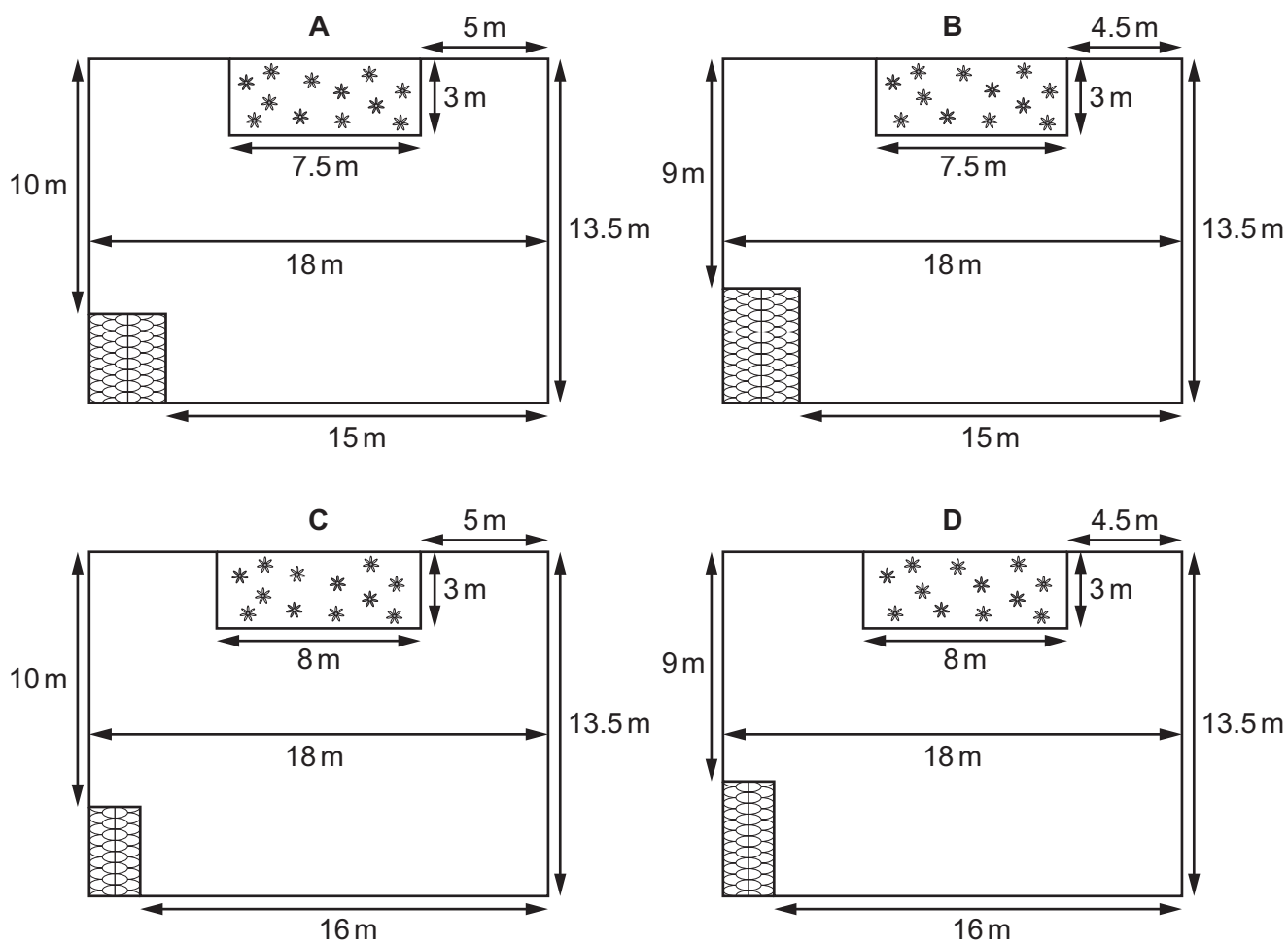

- 19 Some languages use letters which are not in the 26 letters of the **a–z** of the American standard alphabet. There is no consistency in how words containing such letters are considered when sorting into alphabetical order. For example, an **ä** could be placed in four positions according to different national styles. It could be found
- as if just **a** without the " ("American style");
 - as two characters **ae** ("German style");
 - as a separate character between **a** and **b** ("Austrian style"); or
 - as a character after **z**, with the extra letters in the order **åäö** ("Swedish style").

A particular computer program has sorted a list of words using one of the above styles, but we do not know which one.

In how many places in the sorted list might we have to look to find the word **överträda**?

- A** 4
 - B** 8
 - C** 12
 - D** 16
- 20 Long distance lorry drivers are limited by law to not driving more than 10 hours a day. Additionally, they must take a 30-minute break every 2 hours, and at the end of the day's driving they must take a break of 12 consecutive hours.

John drove his lorry from Castor to Remas, a distance of 2700 km. He left Castor at 08:00 on Monday and finally arrived in Remas at 14:00 on Wednesday. He had not driven in the 12 hours before leaving Castor and on his journey he drove for as many hours as the regulations allow.

What was John's average speed during the time that he was actually driving the lorry?

- A** 50 km/h
- B** 90 km/h
- C** 108 km/h
- D** 120 km/h

- 21 Zipf's Law states that if you examine the populations of cities in a country you will find that the second-largest city will have about half the population of the largest, the third-largest will have one third the population of the largest, the fourth-largest one quarter of the population of the largest and so on. In Zipfonia, where Zipf's Law operates exactly, the 10 largest cities make up 30% of the country's total population. Zipfonia has a border with Hedania, which has only half of Zipfonia's population. However Hedania's largest city has a population that is 50% higher than the population of Zipfonia's largest city.

Assuming Zipf's Law works in Hedania, what percentage of Hedania's total population lives in its 10 largest cities?

- A 30%
- B 45%
- C 60%
- D 90%
- 22 A builder is supplying one hundred new beach huts to the town of Seasideville. They will be positioned in a row along the sea-front and will be numbered consecutively from 1 to 100. The builder wants to provide a colourful display and so he paints the huts according to the rules given in the following table.

<i>Colour of hut</i>	<i>Number</i>
Purple	A multiple of both 3 and 5
Red	A multiple of 3, but not a multiple of 5
Blue	A multiple of 5, but not a multiple of 3
Yellow	One more or one less than a multiple of both 3 and 5

The remaining huts are painted green.

How many huts will be painted green?

- A 35
- B 41
- C 47
- D 59

- 23 The average weight of a particular group of people is 72.1 kg. The group is joined by Wilf and Zak.

Which one of the following sets of information may **not** be sufficient to calculate the average weight of the new group including Wilf and Zak?

- A The number of people in the original group and the combined weight of Wilf and Zak
- B The percentage increase in both total weight and total number of people when Wilf and Zak join
- C The total weight of the original group and the combined weight of Wilf and Zak
- D Wilf's and Zak's individual weights and the number of people in the original group heavier than each
- 24 On the first day of every month I transfer \$100 into my savings account and then give 10% of the total amount of money in the account to charity. No other money goes in or out of the account (my interest is paid into a different account).

Which of the graphs below, if suitably labelled, could **not** show the amount of money in the account at the end of each month, during a sixth-month period?

A

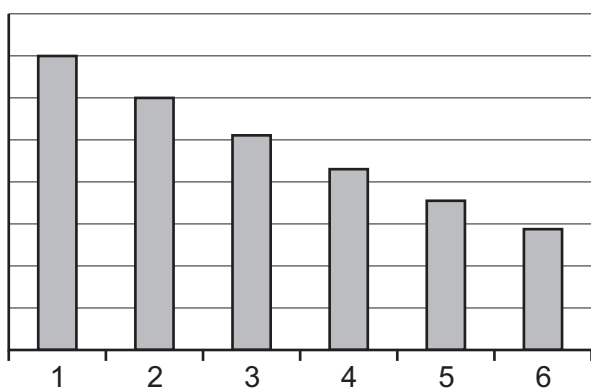

B

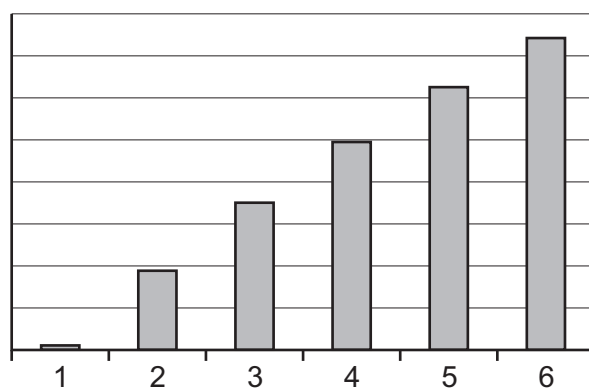

C

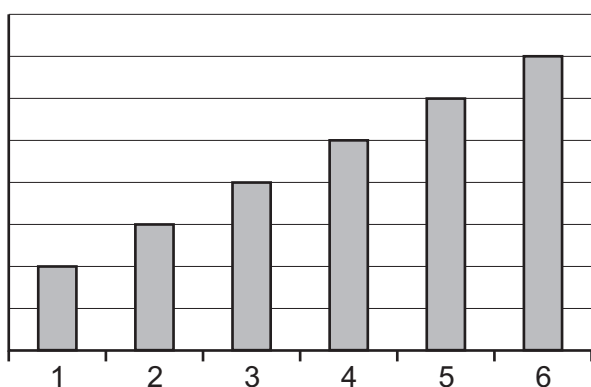

D

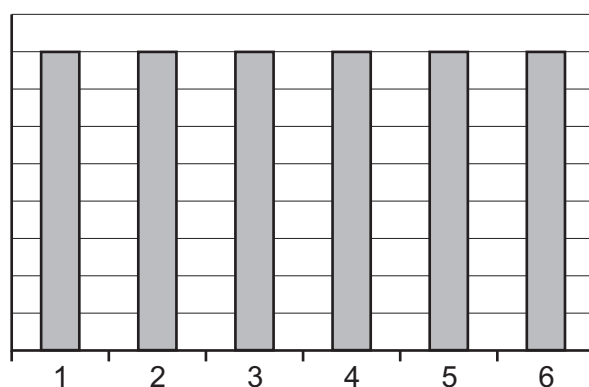

- 25 Roma makes scented candles, which she sells for \$5 each or \$11 for 3. Yesterday she took 200 candles with her to a craft fair and sold them all, taking a total of \$788.

How many of her candles did Roma sell for \$5 at the craft fair?

- A 41
 - B 53
 - C 74
 - D 94
- 26 Melanie bought 3 oranges, 4 pears, 5 apples and 6 bananas for a total cost of \$3.10. She remembers that the price of one of the fruits was 12¢ each, one was 15¢ each, one was 20¢ each and one was 25¢ each, but she has forgotten which was which.

What was the price of each banana?

- A 12¢
 - B 15¢
 - C 20¢
 - D 25¢
- 27 I need to travel from Chilaw to Colombo Fort, either by bus or train. The road runs at all times extremely close to the train tracks, but the bus travels only 5 km in the time that the train travels 7 km. Both bus and train leave Chilaw at the same time, and they both arrive at Colombo Fort at the same time, because the train makes a lengthy stop at Negombo, which the bus does not.

I have been given all of the following pieces of information. Which one is **not** needed to determine my time of arrival at Colombo Fort by train?

- A The departure time from Chilaw
- B The distance from Chilaw to Colombo Fort
- C The duration of the train's stop at Negombo
- D The speed at which the bus travels

- 28 Charles's journey from his home to his school takes a varying amount of time depending on when he leaves, the volume of traffic on the roads, the weather, and how late the bus is when it arrives. The longest bus journey time is 35 minutes, the average 25 minutes, and the shortest 20 minutes. The bus, which is timetabled to run every 15 minutes, can be as much as 12 minutes late. He has to arrive at school no later than 08:00 to ensure he is able to go on a school trip.

Given that his walk to the bus stop takes just under two minutes, at what time must he leave home to make sure he is able to go on the school trip?

- A 06:56
- B 07:02
- C 07:06
- D 07:08

- 29 In a cycle time trial, the riders set off at two-minute intervals over a fixed 50 km route and are timed individually. The winner is the rider who completes the course in the shortest time. In one time trial of 64 riders, one cyclist managed to overtake three of the riders who had set out before her, four cyclists overtook two riders, and seven overtook one rider. No cyclist suffered the humiliation of being overtaken by more than one rider, and all riders completed the course.

How many riders, in this time trial, started and finished the course with the same number of riders in front of them?

- A 30
- B 34
- C 46
- D 52

- 30 In Cameronia you pay no income tax on the first \$20 000 of your annual income. You have to pay 20% in tax of any income above \$20 000 and up to \$100 000, and you have to pay 40% in tax of any income above \$100 000. Edwina is a taxpayer in Cameronia.

Which of the following statements would **not** be sufficient by itself to enable the calculation of Edwina's income before she pays tax?

- A Edwina pays 20% of her total income in tax
- B Edwina pays \$24 000 less than 40% of her total income in tax
- C Edwina pays \$24 000 in tax
- D Edwina's income after tax is \$96 000

BLANK PAGE

Permission to reproduce items where third-party owned material protected by copyright is included has been sought and cleared where possible. Every reasonable effort has been made by the publisher (UCLES) to trace copyright holders, but if any items requiring clearance have unwittingly been included, the publisher will be pleased to make amends at the earliest possible opportunity.

To avoid the issue of disclosure of answer-related information to candidates, all copyright acknowledgements are reproduced online in the Cambridge International Examinations Copyright Acknowledgements Booklet. This is produced for each series of examinations and is freely available to download at www.cie.org.uk after the live examination series.

Cambridge International Examinations is part of the Cambridge Assessment Group. Cambridge Assessment is the brand name of University of Cambridge Local Examinations Syndicate (UCLES), which is itself a department of the University of Cambridge.