



UNIVERSITY OF CAMBRIDGE INTERNATIONAL EXAMINATIONS
General Certificate of Education Advanced Level

THINKING SKILLS

9694/33

Paper 3 Problem Analysis and Solution

October/November 2013

1 hour 30 minutes

Additional Materials: Answer Booklet/Paper
 Electronic Calculator



READ THESE INSTRUCTIONS FIRST

If you have been given an Answer Booklet, follow the instructions on the front cover of the booklet.

Write your Centre number, candidate number and name on all the work you hand in.

Write in dark blue or black pen.

Do not use staples, paper clips, highlighters, glue or correction fluid.

DO NOT WRITE IN ANY BARCODES.

Answer **all** the questions.

Start each question on a new answer sheet.

Calculators should be used where appropriate.

At the end of the examination, fasten all your work securely together.

The number of marks is given in brackets [] at the end of each question or part question.

This document consists of **9** printed pages and **3** blank pages.



1 Study the information below and answer the questions. Show your working.

A lighting director wants to project shadows onto a screen as a backdrop to a play. To achieve this, she shines a single light on the back of the screen and places squares upright on tracks between the light and the screen.

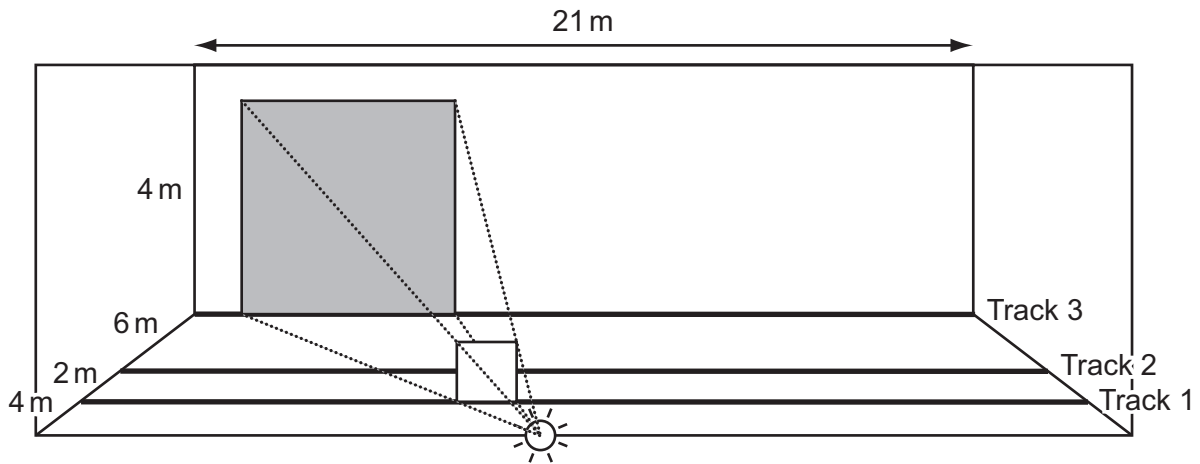

The screen is 21 metres wide and 4 metres high, and the light source is 12 metres behind the screen, in the centre at floor level. The lighting director is able to place her squares on any of three tracks running parallel to the screen. Track 1 is 8 metres from the screen, track 2 is 6 metres from the screen and track 3 lies right next to the screen.

She is considering where to place her squares, which are all of side length 1 metre. She decides that she will refer to a square's position by the distance of its left-hand edge from the left-hand wall. She further decides only to place squares at distances which are whole numbers of metres from the left-hand wall. Although shadows may fall on the side walls, she is only interested in the areas and shapes of shadows that fall on the screen itself.

- (a) What is the area of the largest shadow that can be projected onto the screen using a single square? [1]
- (b) Where should a square be placed, on track 1, in order for the shadow on the screen to be as close as possible to the left-hand side of the screen? [2]
- (c) The lighting director wishes to project two non-touching square shadows onto the screen. One square is placed at the centre of track 1 (i.e. 10 m from the left).
In how many positions can the second square be placed on track 2? [2]
- (d) Show that it is possible to project a shadow which has an area of 12m^2 using just two squares. Give an example for the positions of the two squares. [2]
- (e) (i) Give a possible area for a shadow projected using two squares that is not a whole number of square metres. [1]
- (ii) What is the smallest **total** area of shadow that it is **not** possible to project onto the screen using just one or two squares, and that is a whole number of square metres? [2]

[Turn over for Question 2]

2 Study the information below and answer the questions. Show your working.

Sometimes, parts of television pictures (such as faces or vehicle numbers) are intentionally obscured using a process called pixellization.

In the 2-dimensional world of Flatland, an equivalent process is used on their 1-dimensional televisions. Pictures are made up of a line of pixels representing shades of grey from 0 (black) to 15 (white). For example:

3	4	4	7	10	9	8	12	15	13	13	10	9	4
---	---	---	---	----	---	---	----	----	----	----	----	---	---

Pixellization in Flatland is achieved by replacing each pixel in a row of **four** adjacent pixels with their mean value, rounded down. For example, the picture shown above might become

3	4	4	7	9	9	9	9	15	13	13	10	9	4
---	---	---	---	---	---	---	---	----	----	----	----	---	---

(a) What would be the value in all four pixels if 15 13 13 10 were pixellized? [1]

(b) What is the lowest original value possible for one of the pixellized pixels in the line below?

7	6	4	3	13	13	13	13	10	12	12	15	14	12
---	---	---	---	----	----	----	----	----	----	----	----	----	----

[1]

If the pixellized area stays in the same place on the screen but the camera moves, it may be possible to know something about the obscured pixels.

7	8	10	13	12	12	12	12	14	14	5	6	7	9
---	---	----	----	----	----	----	----	----	----	---	---	---	---

8	10	13	15	11	11	11	11	14	5	6	7	9	11
---	----	----	----	----	----	----	----	----	---	---	---	---	----

(c) If one of the obscured pixels in the pictures above is 5, what possible combinations could there be for the other two? [3]

Fred knows that the picture behind this line with multiple pixellized areas is just black and white:

3	3	3	3	7	7	7	7	7	7	7	7	...
---	---	---	---	---	---	---	---	---	---	---	---	-----

Here is the same picture, but with pixellization starting at the 3rd, 7th, and 11th pixels:

15	0	7	7	7	7	7	7	7	7	3	3	...
----	---	---	---	---	---	---	---	---	---	---	---	-----

(d) What is the underlying picture? [3]

When a picture made of a repeating pattern is pixellized throughout, it might appear different depending on where in the pattern the pixellization starts.

- (e) (i) Consider repeating black and white patterns which are pixellized throughout. Give an example of a pattern which yields the same value in all the pixels when pixellization starts at one place, but not if it starts at another. [1]
- (ii) What is the shortest length of such a pattern? [1]

3 Study the information below and answer the questions. Show your working.

Hyacinth wishes to drive to see her sister who lives in a town which is 200 km away. Their towns are connected by a highway, but there are also numerous smaller roads connecting all the towns along the route.

Hyacinth is considering how much of the journey she should spend going fast on the highway, how much on the country roads at a medium speed, and how much going through the villages along the minor roads at a slow speed.

After considering the map, she realises that the junctions between the different roads occur roughly every 10 km, and that the possible routes can be modelled by the diagram below.

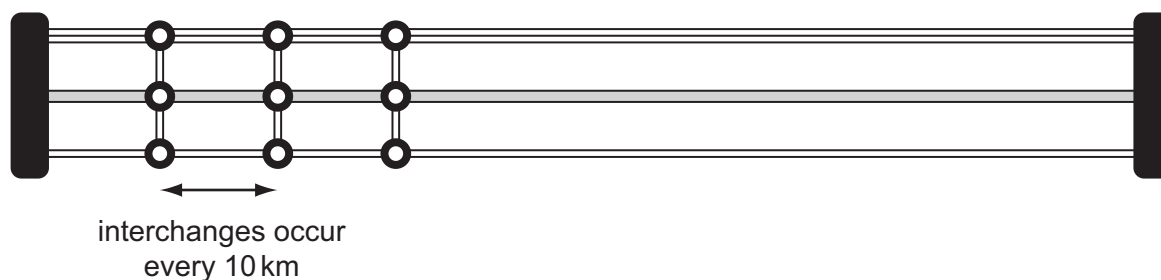

The interchanges between the three types of road can be ignored for the purposes of calculation. You can assume that Hyacinth drives as fast as the speed limit allows when she is on each type of road. The highway has a speed limit of 120 kilometres per hour (km/h), the country roads have a speed limit of 80 km/h, and the minor roads have a speed limit of 40 km/h.

Hyacinth knows that her car uses 3 litres of fuel every 10 km when travelling at 120 km/h; it uses 2 litres every 10 km at 80 km/h, and 1 litre every 10 km at 40 km/h.

For the purpose of this model, you can assume that the time spent accelerating and decelerating is negligible.

(a) Show that Hyacinth will use 60 litres of fuel if she travels the entire journey to her sister's town on the highway. [1]

(b) Suppose that Hyacinth drives on the highway for the first 10 km and the last 10 km, and travels an equal distance on each of the three different types of road for the rest of the journey.

Calculate the amount of time this journey would take. [2]

She loves the variety of scenery that comes from driving on different types of road, and decides that the following requirements should be fulfilled if the journey to her sister's town is to be an enjoyable one.

- The journey must consist of some sections of each of the three types of road.
- The journey must consist of more country road than minor road, and more minor road than highway. Equal sections of country road and minor road, or minor road and highway, will not be good enough.

Assume that these requirements are fulfilled for the remaining parts of the question.

(c) What is the minimum amount of fuel that she could use for the journey? State how long this journey would take. [3]

- (d) If she maximises the amount of time she spends on the highway, what is the minimum amount of time that the journey would take? State how much fuel this journey would use. [3]
- (e) Show that it is possible to complete an enjoyable journey in less than 3 hours, using only 37 litres of fuel. [3]

A further requirement that she places on an ideal journey is that no part shall consist of more than 20 km uninterrupted on any one type of road.

- (f) Show that it is possible to complete a journey that fulfils all three requirements and takes less than 3 hours. Give an example listing the different parts of the journey and the order in which they should be driven. [3]

4 Study the information below and answer the questions. Show your working.

Celerity is a fast-moving game of mental agility for 2 players, played over 8 rounds. This is the electronic equipment used to play Celerity, showing a game in progress between Lee (player A) and Ric (player B):

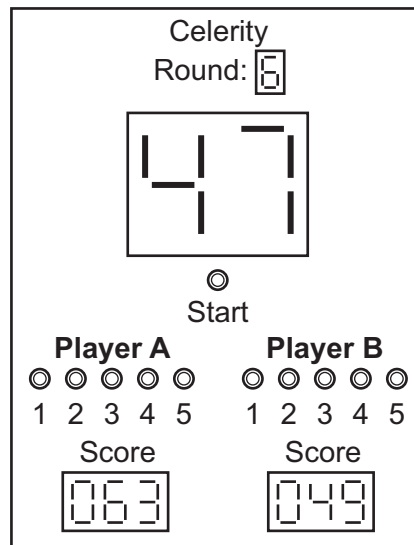

Each round begins when one player presses the START button: always player A in rounds 1, 3, 5 and 7, and player B in rounds 2, 4, 6 and 8. This causes the number 90 to appear on the central display, and triggers the automatic timing mechanism. He or she must then press one of their number buttons (1, 2, 3, 4 or 5) within 10 seconds. Play subsequently alternates between the two players, with a time limit of 10 seconds for each turn. When a number button is pressed, that number is subtracted from the central display.

The display freezes, bringing the round to an end, and the number shown is automatically added to the opponent's score, when a player:

presses the same number button for the fourth time in that round, in which case the display freezes **before** the subtraction can occur,

or causes a multiple of 3 (other than 90) to appear,

or fails to press a number button within 10 seconds.

If the display reaches zero, the round is over without either player scoring any points.

In the game shown above, Lee is 14 points ahead of Ric, even though Ric has won one more round than Lee.

- (a) (i) What is the longest possible time that a round of Celerity can take to complete, from the pressing of the START button? [2]
- (ii) Assuming a maximum pause of 2 minutes between rounds, what is the longest time it can take to play a full game of Celerity? [1]
- (b) What is the largest number and what is the smallest number that can appear on the central display, when the players have had 3 turns each and the round has not finished? [2]

The 6th round of the game between Lee (player A) and Ric (player B) has so far progressed as follows, resulting in the current display of 47:

Ric	Lee
5	2
3	3
1	2
3	3
4	5
1	2
4	5

- (c) List **all** the possibilities for the next turn for Ric and the subsequent turn for Lee (e.g. Ric 3, Lee 3) that will **not** cause the display to freeze. [3]

The 5th round of the game between Lee and Ric developed as follows:

Lee	Ric
2	5
4	5
3	4
5	1
2	4
5	1
5	3
1	5
4	3
2	3
3	1

At this point, with the display showing 19, Lee mistakenly thought that only his 1 and 4 buttons had not been pressed three times during the round. He chose to press his 4 button. This terminated the 5th round.

- (d) (i) Why did Lee choose to press his 4 button? [1]
- (ii) Which of his buttons could Lee have pressed that would not have caused the display to freeze? [1]
- (iii) Show how the round could have continued from 19 until the display reached 0. [2]

The number of points scored in the first three rounds of the game between Lee and Ric were as follows:

round 1: 29

round 2: 11

round 3: 23

- (e) (i) How many points were scored in round 4? [2]
- (ii) Which of the first four rounds were won by Lee and which by Ric? [1]

BLANK PAGE

Permission to reproduce items where third-party owned material protected by copyright is included has been sought and cleared where possible. Every reasonable effort has been made by the publisher (UCLES) to trace copyright holders, but if any items requiring clearance have unwittingly been included, the publisher will be pleased to make amends at the earliest possible opportunity.

University of Cambridge International Examinations is part of the Cambridge Assessment Group. Cambridge Assessment is the brand name of University of Cambridge Local Examinations Syndicate (UCLES), which is itself a department of the University of Cambridge.