

THINKING SKILLS

9694/13

Paper 1 Problem Solving

May/June 2014

1 hour 30 minutes

Additional Materials: Multiple Choice Answer Sheet
Soft clean eraser
Soft pencil (type B or HB is recommended)

* 5 4 0 3 3 0 8 6 4 5 *

READ THESE INSTRUCTIONS FIRST

Write your Centre number, candidate number and name on all the work you hand in.

There are **30** questions on this paper. Answer **all** the questions.

For each question there are four possible answers **A, B, C** and **D**. Choose the **one** you consider correct and record your choice in pencil on the separate answer sheet.

Read very carefully the instructions on the answer sheet. Ignore responses numbered 31 – 40 on the answer sheet.

DO NOT WRITE IN ANY BARCODES.

INFORMATION FOR CANDIDATES

Each correct answer will score one mark. A mark will not be deducted for a wrong answer.

This document consists of **18** printed pages and **2** blank pages.

- 1 I was playing golf for the first time and was trying to work out the best way of getting my ball in the hole with the fewest shots.

I decided that the shots should be of the following lengths in order to avoid hazards.

Shot 1	Shot 2	Shot 3	Shot 4	Shot 5
100 m	50 m	40 m	20 m	3 m

Which of the following pie charts represents the distances of the shots?

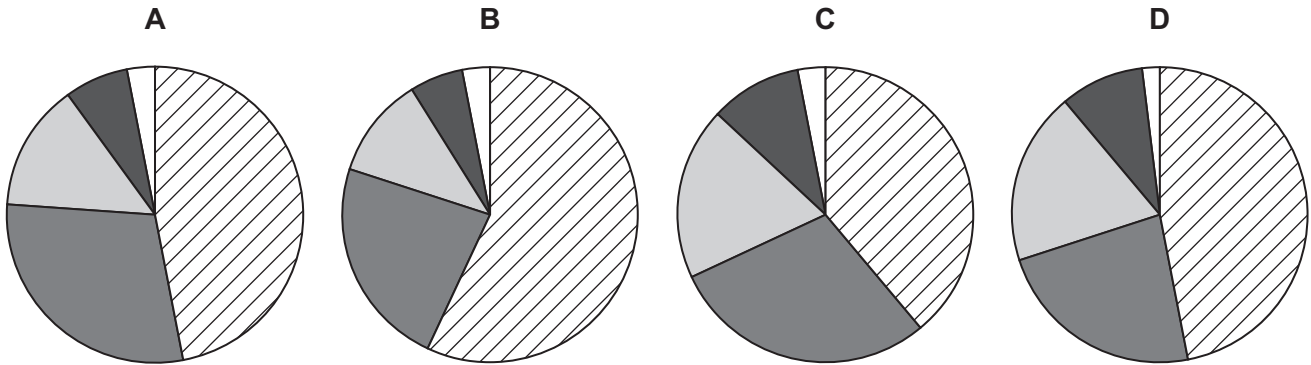

- 2 The chart below shows the staff numbers in the UK National Health Service in 1997 and 2005.

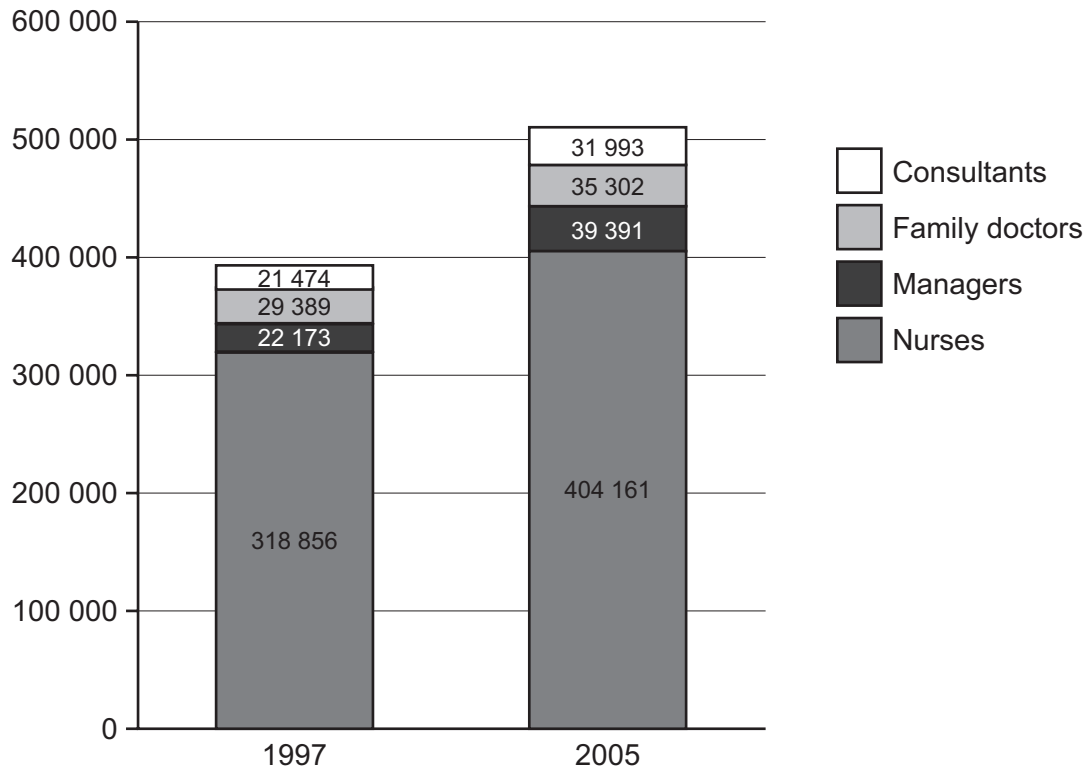

Which category showed the biggest percentage increase between these dates?

- A** Consultants
B Family doctors
C Managers
D Nurses
- 3 Ali and Ben are playing card games. They have 14 chocolate bars to share and decide they will play four games, the prize for the winner of each game being 2, 3, 4 and 5 bars in order of play. Games cannot be drawn.

At the end, Ali has 9 chocolate bars.

Which game can we be certain Ali won?

- A** The first game
B The second game
C The third game
D The fourth game

- 4 Steven normally buys cartons of orange juice from his supplier for \$1 each and sells them in his shop for \$1.40. Next week shops will run an offer of “Buy one, get one half price” and shopkeepers will be able to buy the cartons of orange juice from the supplier for 80¢ each. Steven wants to make the same average profit per carton as he did before the offer was applied.

Assuming all customers take advantage of the offer, what price should Steven choose to sell the orange juice at?

- A \$1.20
 B \$1.33
 C \$1.60
 D \$2.40
- 5 Imperfections in the manufacturing process mean that there are slight variations in the dimensions of machined parts. The range of the sizes of the parts in four batches of shafts and holes was measured accurately.

Which one of the four batches shown below will contain parts such that some of the shafts will not fit in all the holes?

	<i>Range of shaft sizes</i>	<i>Range of hole sizes</i>
<i>Batch 1</i>	50.000 – 50.100	50.000 – 50.050
<i>Batch 2</i>	49.900 – 50.000	50.010 – 50.050
<i>Batch 3</i>	49.900 – 49.950	50.000 – 50.050
<i>Batch 4</i>	49.900 – 49.950	49.950 – 50.000

- A Batch 1
 B Batch 2
 C Batch 3
 D Batch 4

- 6 Drawings can be made on a transparent board which can then be viewed from either side and rotated about a horizontal axis.

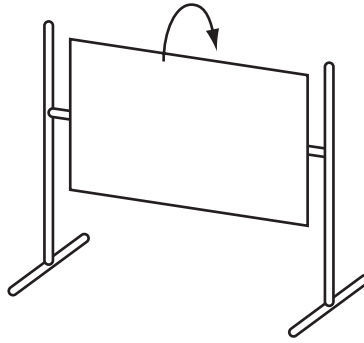

The word below is written.

NUT

Which one of these would never appear?

A
TUN

B
NU

C
TUN

D
TUN

- 7 The Monstrosity is a very popular ride at Happy Daze theme park. Each ride lasts for 5 minutes and can accommodate 36 people. There is a 3 minute period between rides for unloading and reloading.

There has been a huge queue for The Monstrosity all day, and with exactly 1 hour to go before closing time there are still 564 people waiting. No ride will start unless it can finish before closing time.

The ride currently in progress set off 4 minutes ago.

How many of these 564 people will **not** be able to ride The Monstrosity today before closing time?

- A 132
- B 252
- C 276
- D 312

- 8 An hourly tram service connects the town of Upperville with the popular beach of Lowsands.

At ten past each hour the tram sets off from Upperville, covering the 8 km route at a constant speed of 40 km/h.

At half past the hour it begins its return journey, which, because it is uphill all the way, it covers at a constant speed of 24 km/h.

Which one of these graphs shows the tram's progress from Upperville to Lowsands and back?

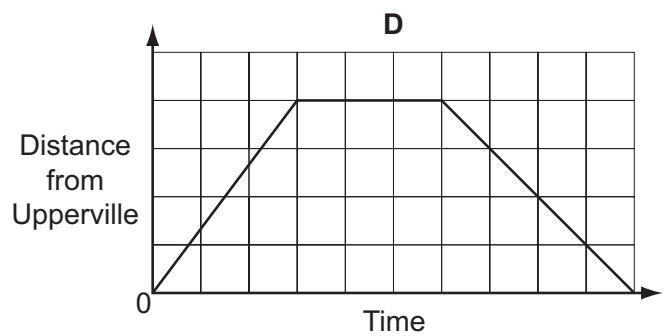
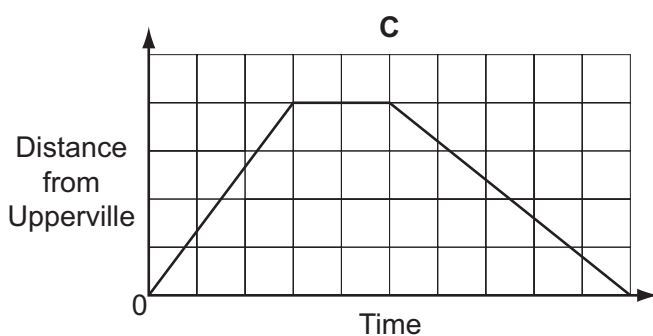
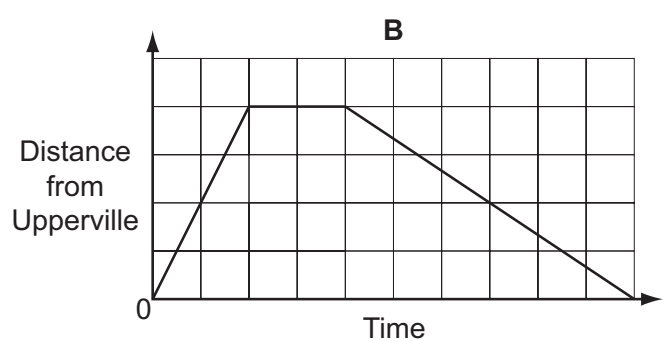
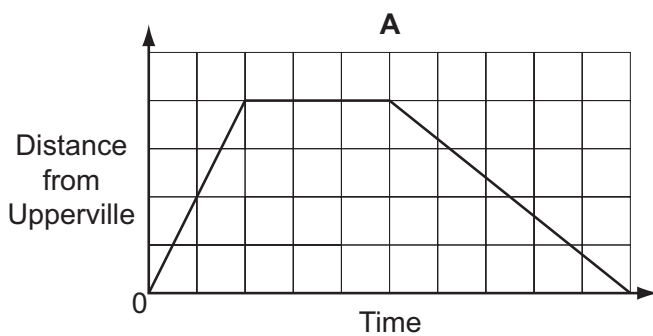

- 9 Joe's Catering Service provided their usual 3 kg of dried fruit for yesterday's picnic. Each child attending the picnic was given, and ate, 100 g of dried fruit. 400 g of dried fruit was left over at the end of the day. There will be double the number of children at today's picnic and each child will be given 150 g of dried fruit. Joe's Catering Service will use up the surplus dried fruit from yesterday.

How much more than the 3 kg of dried fruit which they usually provide will Joe's Catering Service have to bring to the picnic today?

- A 4.4 kg
 B 4.8 kg
 C 7.4 kg
 D 7.8 kg
- 10 Ivor has a large vegetable plot which he has divided into 7 smaller plots, as shown in the diagram below. He grows a different crop in each of 6 of the plots, and in the other plot he has no crops, but improves it with manure. The contents of the plots move in a clockwise direction from year to year. The diagram shows what crops were grown in Year 1.

1 Potatoes	2 Peas	3 Carrots	4 Manure
	7 Leeks	6 Turnips	5 Cabbages

There has to be a gap of 4 years before the same crop can be grown in a given plot. Carrots cannot be grown in a plot that has been given manure in the previous year. Where carrots would be placed in the previously manured plot the sequence moves forward by a year and so in Year 2 plot 4 contains peas.

Which crop will be grown in Plot 3 in Year 3?

- A Cabbages
 B Carrots
 C Peas
 D Turnips

- 11 These are the four energy providers Mr Jones can choose between and their rates for the coming year.

	<i>Arctic Heating</i>	<i>Windy Passage</i>	<i>Shock Electrics</i>	<i>Pongy Gas</i>
<i>Annual charge</i>	\$4500	\$1200	\$1000	\$2600
<i>Tariff</i>	Day: 06:00 – 21:00 \$2.00 per unit Night: 21:00 – 06:00 \$1.00 per unit	\$1.20 per unit to 15 000 units \$2.10 per unit over 15 000 units	\$1.10 per unit to 12 000 units \$2.20 per unit over 12 000 units	\$1.50 per unit with no limit

Mr Jones uses 22 000 units a year. He uses 14 000 between 21:00 and 06:00 and 8000 in the rest of the day.

Which supplier is the cheapest one for Mr Jones to choose?

- A Arctic Heating
 - B Windy Passage
 - C Shock Electrics
 - D Pongy Gas
- 12 The price of a box of breakfast cereal is made up of four elements as follows:

Ingredients	65¢
Manufacturing cost	41¢
Transport	21¢
Retailer's profit	57¢

A journalist entered this data into her computer. Unfortunately she failed to enter one of the elements, and as a result this pie chart appeared on her screen:

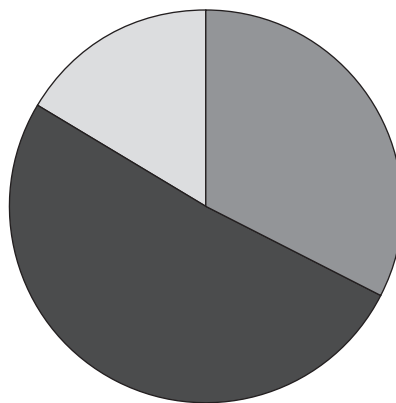

Which element had she not entered?

- A Ingredients
- B Manufacturing cost
- C Transport
- D Retailer's profit

- 13 At the end of a church service, a large number of identical hymn books need to be stacked on shelves with a rectangular space of 35 cm horizontally and 12 cm vertically. The books are cuboids with dimensions 2 cm, 5 cm and 10 cm.

They can be put onto a shelf in two different ways:



on their end

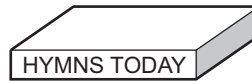

on their side

Peter puts the books into his shelf all on their **ends**.

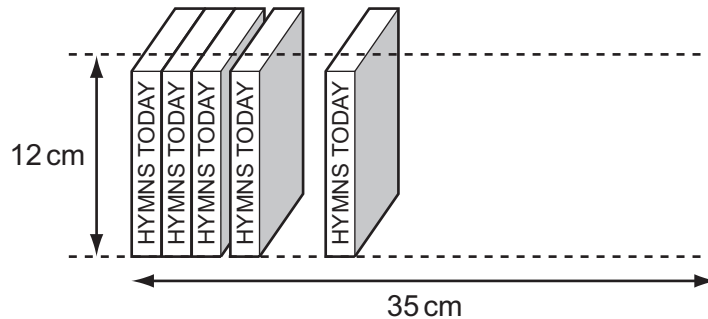

Paul puts the books into his shelf all on their **sides**.

How many more books can Paul fit in than Peter?

- A 0
- B 1
- C 3
- D 4

- 14 A piece of string, 48 cm long, is folded in half lengthways, then in half again and then in half again. It is then cut through all strands at some point in its length. At least one of the pieces is 5 cm long.

Which of the following could **not** be the length of one of the other pieces?

- A 2 cm
- B 3.5 cm
- C 8 cm
- D 10 cm

15 The Government of Burton Island is trying to decide how to spend the \$7.25 million left in its budget. There are nine projects which have been proposed:

- Nationalising the ferry service: \$1.66 million
- Building a new hospital: \$1.04 million
- Subsidy for introducing broadband computer access: \$0.61 million
- Building a new central library: \$1.11 million
- Irrigation scheme: \$1.23 million
- A non-commercial national television service: \$0.48 million
- Free public transport: \$1.62 million
- A new international airport: \$3.92 million
- A bullet-proof car for the president: \$0.43 million

The Government has already decided that they must build the new international airport and irrigation scheme. They chose two other projects which used up the entire budget of \$7.25 million.

Which one of the following projects must have been one of the other two chosen?

- A** Nationalising the ferry service
- B** Building a new hospital
- C** Building a new central library
- D** A non-commercial national television service

16 I recently bought a new board game and I am going to play tonight with three of my friends. The instructions say that it will take 10 minutes to set up the game and then the amount of time to play the game will depend on the number of players. There are 5 rounds to the game and in each round every player should need 2 minutes to make their move. At the end of each of rounds one to four some parts of the game need to be set up for the next round. This takes 5 minutes each time. As we have not played the game before I am going to allow twice the normal amount of time for setting up at the start of the game and making our moves in the first round.

How long should I expect the game to take (including the set up time)?

- A** 70 minutes
- B** 80 minutes
- C** 88 minutes
- D** 93 minutes

- 17 John flies to Geneva for a holiday of 7 nights in Switzerland. From Geneva he has to travel by train to his destination which costs \$70 for a single journey. He plans 6 day trips. The fares for these trips are \$124, \$114, \$44, \$48, \$42 and \$122. As he is meeting different friends on these day trips, they have to take place in the order listed. At the end of the week he has to travel to Geneva to return home. He has a range of special passes available to reduce the cost of his journeys.

Swiss Pass	Flexi Pass	Transfer Card	Swiss Card
Cost: \$425 4 consecutive days' travel	Cost: \$375 Any 4 days travel	Cost: \$150 Travel from airport to destination and back	Cost: \$210 Free travel from airport to destination and back plus half-price travel for remainder of holiday

Which of these passes should John buy to minimise his travel costs?

- A** Swiss Pass
- B** Flexi Pass
- C** Transfer Card
- D** Swiss Card
- 18 Anna is sorting her beads into a tray with a lot of divisions. She is not sure how to organise them.
- 70 are round and 30 are cubical.
 - 20 are 5 mm across, 60 are 7 mm across and 20 are 10 mm across.
 - 80 are red, 15 are blue and 5 are green.

What is the smallest number of round, 7 mm, red beads there could be?

- A** 10
- B** 20
- C** 40
- D** 60

- 19 A cyclist went on a 20 kilometre ride starting at the top of a hill. He accelerated from his starting point until he reached a certain fast speed which he kept up until he reached the bottom of a valley 10 kilometres from where he started. From the valley bottom he faced 10 kilometres of roads going uphill. From the valley bottom he slowed down until he was riding at a comfortable but slow speed which he kept up until the end of his ride.

Which of the following graphs best represents the distance the cyclist had ridden at any time from the start of the ride?

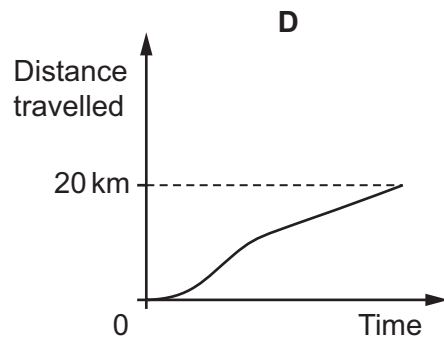
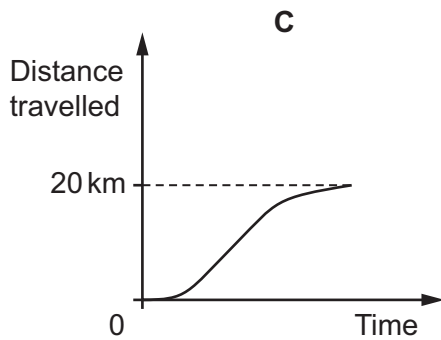
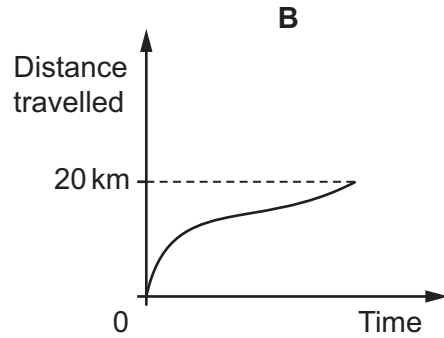
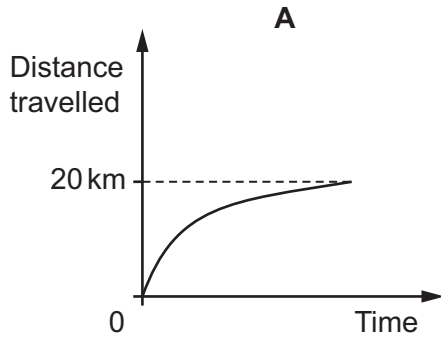

- 20 A square piece of paper is folded over equally four times and then the corners are cut off.

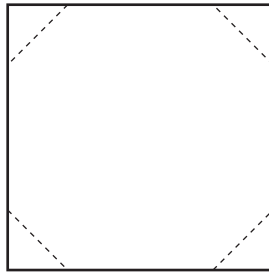

The paper is then unfolded to reveal a pattern.

Which of the following is the resulting pattern?

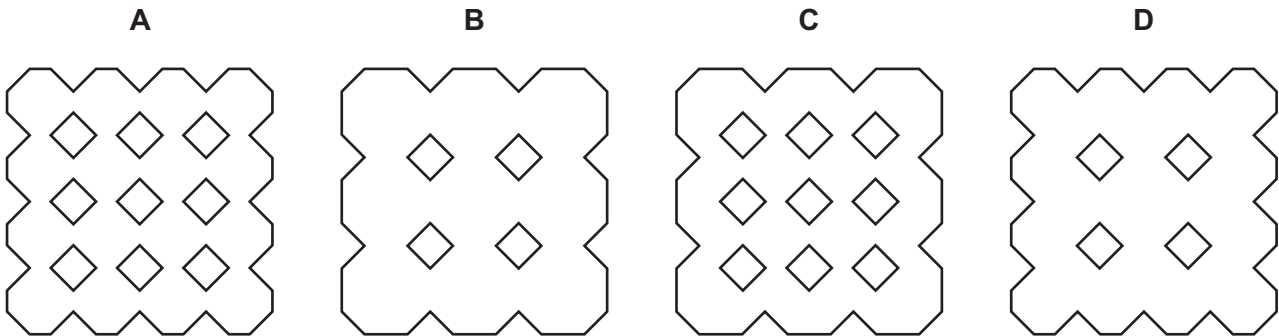

- 21 In a television game show, contestants are awarded money for each question that they get right. The questions are divided into two categories: easy and difficult. Contestants choose the difficulty of the question that is to be asked each time. Any two questions with the same difficulty are worth the same amount of money, which is always a whole number of dollars. Easy questions are worth less than difficult questions.

At the end of the contest all of the competitors had been asked 10 questions. Sue and Helen both chose to answer 5 easy and 5 difficult questions, while Bill chose 10 easy questions.

Sue answered 8 questions correctly and finished with \$220

Bill answered all of the questions correctly and finished with \$200.

Helen answered 9 questions correctly.

Which of the following could **not** be the amount that Helen won?

- A \$240
- B \$252
- C \$255
- D \$260

- 22 I have a choice of three types of drink at work: tea, coffee, and hot chocolate. I get my drinks from a machine. The standard method for getting a drink requires the following steps:
- Press a button for the type of drink I want.
 - Press a button to add milk (optional).
 - Press the button again for extra milk (optional).
 - Press a button to add sugar (optional).
 - Press the button again for extra sugar (optional).
 - Press a button to make the drink.

For example, to have tea with the normal amount of sugar and extra milk requires pressing 5 buttons (tea – milk – extra milk – sugar – start).

For any drink, with any amount of milk and sugar, there is also a three-digit “quick code” which can be used to order the drink. Using the quick code requires 5 button presses in total (quick code button – three digits – start).

How many of the “quick codes” require **more** button presses than the standard method for obtaining the drink?

- A 6
 - B 9
 - C 12
 - D 18
- 23 Mike is a door-to-door salesman hoping to sell brass door numbers (screws included) to residents in Green Street. There are 30 houses, numbered consecutively from 1 to 30. He has a total of 50 digits, five of each i.e. five 0s, five 1s etc. up to and including five 9s.

Mike will only visit houses for which he has sufficient digits to make up the whole house number. No resident will buy more than the minimum requirement to furnish their own door.

If Mike charges \$2 for each digit, what is the most money he could collect from sales on Green Street?

- A \$42
- B \$54
- C \$58
- D \$70

- 24 The powder called Petsup is a new healthy dietary supplement for a variety of pets. It consists of a mixture of Ingredient A and Ingredient B. The suitable proportion of A and B is different for different types of pets, but there is always at least as much B as A. Currently, there are a number of different blends on the market as shown in the table below.

<i>Blend</i>	<i>Percentage of A in blend</i>	<i>Percentage of B in blend</i>	<i>Price per 100g</i>
Petsup Bronze	50	50	\$3.00
Petsup Silver	30	70	\$6.00
Petsup Gold	20	80	\$7.00
Petsup Platinum	10	90	\$8.00

Customers who want a different blend buy suitable amounts of two of the Petsup blends, and mix them together. Marianne is thinking of putting a new blend on the market containing 40% of A and 60% of B. She thinks she can sell this blend for no more than the price per 100g that people would pay if they bought two of the current Petsup products and mixed them together to produce a 40:60 blend.

What is the highest price per 100g that Marianne can charge for the new blend?

- A \$4.25
 B \$4.33
 C \$4.50
 D \$5.00
- 25 Richard has just returned from his holiday in Bolandia. Before he left he exchanged \$300 into bols (Б). To make the exchange, a fixed amount of money (the commission) was taken off the \$300 and then the remaining money was exchanged for Б540. When he got back, Richard had Б180 left, which he exchanged back into dollars. This time the Б180 was exchanged into dollars first and then the commission was taken off, leaving Richard with \$60. The commission charges and exchange rates were the same at both exchanges.

If Richard had exchanged \$500 at the start of his holiday, how many bols would he have received?

- A Б840
 B Б900
 C Б940
 D Б1000

- 26 Pugwash sailed a boat at a constant but unknown speed due North. He then turned 90° and sailed at the same constant speed due East. Pugwash wanted to know how much time, at the same constant speed, it would take to sail in a straight line from where he was, back to where he started.

Which one of the following sets of information would enable Pugwash to find out the answer to his problem?

- A** The distance he had sailed North, and the distance he had sailed East.
B The distance he had sailed North, and the time for which he had sailed East.
C The time for which he had sailed North, and the time for which he had sailed East.
D The total distance he had sailed, and the total time for which he had sailed.
- 27 The promenade at Kirr-on-Sea is straight and flat. It is exactly 6 km from end to end.

Every day, Frank and Marc exercise along the promenade. They always start and finish together at the eastern end. However, Frank runs the whole length of the promenade at 5 m/s, rests for 5 minutes, then runs back at the same speed, whilst Marc runs 3.6 km at 4 m/s, then turns round and walks back at 2 m/s.

Which one of the following graphs, suitably labelled, shows how far apart Frank and Marc are during the course of their daily exercise?

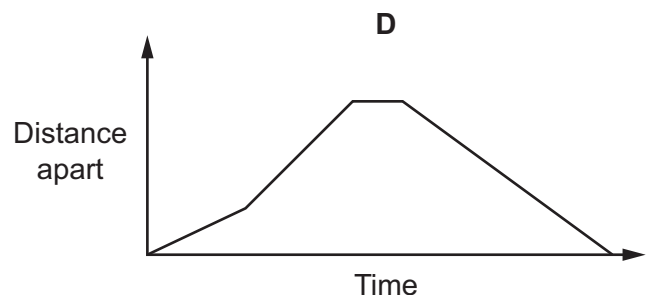
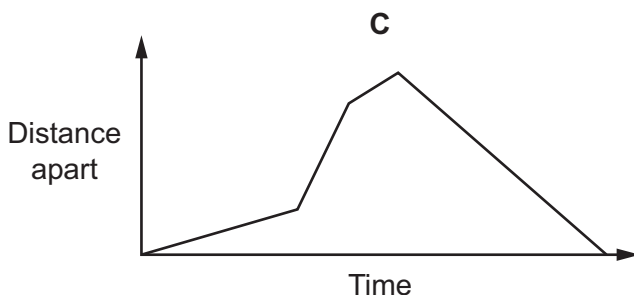
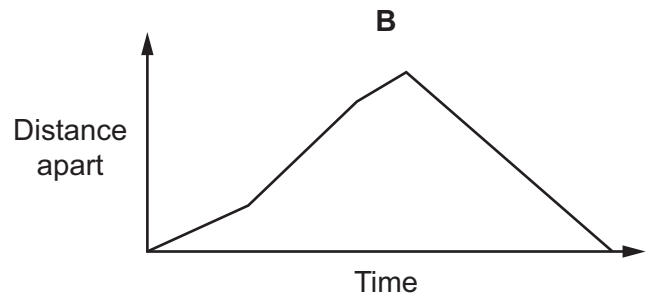
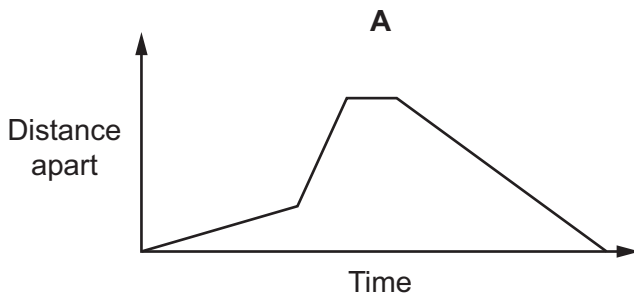

28 A local shop offers a delivery service for a charge which is calculated as follows:

- There is a fixed charge of \$5 for the service.
- An extra amount (a whole number of cents) is added for every 5 kg that the order weighs.
- An extra amount (a whole number of cents) is added for every 5 km that must be driven to make the delivery.

The additional charges are only added once a complete 5 kg or 5 km is added. For example, a journey of 4 km to deliver 2 kg of goods will cost \$5.

One delivery of 22 kg involves a journey of 14 km. The total price for this delivery was \$5.90. A second delivery has a total weight of 17 kg and involves a journey of 6 km.

What is the range of possible prices for the second delivery?

- A** Any value between \$5.25 and \$5.67
- B** Any value between \$5.25 and \$5.88
- C** Any value between \$5.46 and \$5.67
- D** Any value between \$5.46 and \$5.88
- 29 In the Wonternyne Sudoku Challenge, 6 contestants each attempted 5 sudoku puzzles. For each puzzle there was a time limit of 30 minutes, and points were awarded to all contestants who completed it within this time, as follows:

first to finish	5 points
second to finish	3 points
others	1 point each

This was the final points table.

Oliver	15 points
Tariq	11 points
Trudy	10 points
Fatima	9 points
Felix	9 points
Simon	3 points

Which one of the following statements about the Wonternyne Sudoku Challenge is definitely true?

- A** At least three of the puzzles were completed within the time limit by all six contestants.
- B** Each contestant completed at least three of the puzzles within the time limit.
- C** Each of the puzzles was completed within the time limit by at least five contestants.
- D** No contestant was first to finish more than one of the puzzles.

- 30 Two friends, Mike and Noel, decided to meet outside the cinema, and each walked from his own home to the cinema. The two friends walked at constant, but different, speeds. The distance of Mike's house from the cinema is twice the distance of Noel's house from the cinema. On his journey, Noel met another friend Pete and stopped to chat for a while before continuing his walk to the cinema.

Noel's average speed for his journey (including the time he spent chatting with Pete) was $\frac{3}{4}$ of Mike's average speed for his journey.

Which **one** of the following pieces of information is sufficient to find the time between Noel leaving home and arriving at the cinema?

- A The distance between Noel's house and the cinema
- B The steady speed at which Noel walked
- C The time for which Noel stopped to chat to Pete
- D The time taken by Mike to walk from his home to the cinema

BLANK PAGE

Permission to reproduce items where third-party owned material protected by copyright is included has been sought and cleared where possible. Every reasonable effort has been made by the publisher (UCLES) to trace copyright holders, but if any items requiring clearance have unwittingly been included, the publisher will be pleased to make amends at the earliest possible opportunity.

Cambridge International Examinations is part of the Cambridge Assessment Group. Cambridge Assessment is the brand name of University of Cambridge Local Examinations Syndicate (UCLES), which is itself a department of the University of Cambridge.