



UNIVERSITY OF CAMBRIDGE INTERNATIONAL EXAMINATIONS
International General Certificate of Secondary Education

CANDIDATE
NAME

CENTRE
NUMBER

--	--	--	--	--

CANDIDATE
NUMBER

--	--	--	--

* 9 7 0 2 9 9 4 2 6 9 *

COMPUTER STUDIES

0420/12

Paper 1

May/June 2012

2 hours 30 minutes

Candidates answer on the Question Paper.

No Additional Materials are required.

READ THESE INSTRUCTIONS FIRST

Write your Centre number, candidate number and name on all the work you hand in.

Write in dark blue or black pen.

You may use a soft pencil for any diagrams, graphs or rough working.

Do not use staples, paper clips, highlighters, glue or correction fluid.

DO NOT WRITE IN ANY BARCODES.

Answer **all** questions.

No marks will be awarded for using brand names of software packages or hardware.

At the end of the examination, fasten all your work securely together.

The number of marks is given in brackets [] at the end of each question or part question.

For Examiner's Use

--

This document consists of **20** printed pages.



1 Write down **three** of the stages in the system life cycle.

1

.....

2

.....

3

..... [3]

2 Both email and mobile phones can be used to send messages.

Give **one** advantage and **one** disadvantage of using each method when compared to each other.

(i) **Email:**

Advantage

.....

Disadvantage

.....

(ii) **Mobile phones:**

Advantage

.....

Disadvantage

..... [4]

3 A computer system is to have wireless access (Wi-Fi) to the Internet.

State **five** potential security issues.

1

.....

2

.....

3

.....

4

.....

5

.....

[5]

4 A list of **four** printers and **four** different applications which use printers is shown below.

(a) Using arrows, link each printer to the most appropriate application.

Printing documents in a factory environment which is dusty and damp

3D printer

High quality printing of 30 000 colour booklets per day

Dot matrix printer

Producing prototypes in resin of a new design

Colour inkjet printer

Producing a colour poster

Colour laser printer

[4]

(b) Give **one** feature of each printer which makes it appropriate for the application.

3D printer

.....

.....

Dot matrix printer

.....

.....

Colour inkjet printer

.....

.....

Colour laser printer

.....

.....

[4]

5 (a) Give **three** features you would expect to see in a typical Computer Aided Design program.

1

.....

.....

2

.....

.....

3

.....

..... [3]

(b) Describe **three** specialist output devices which could be used with a CAD program when developing a new product.

1

.....

.....

2

.....

.....

3

.....

..... [3]



(c) Describe **two** potential health risks and **one** potential safety risk when using computer systems.

Health risk 1

.....

.....

Health risk 2

.....

.....

Safety risk

.....

.....

[3]

6 Carefully study the following flowchart:

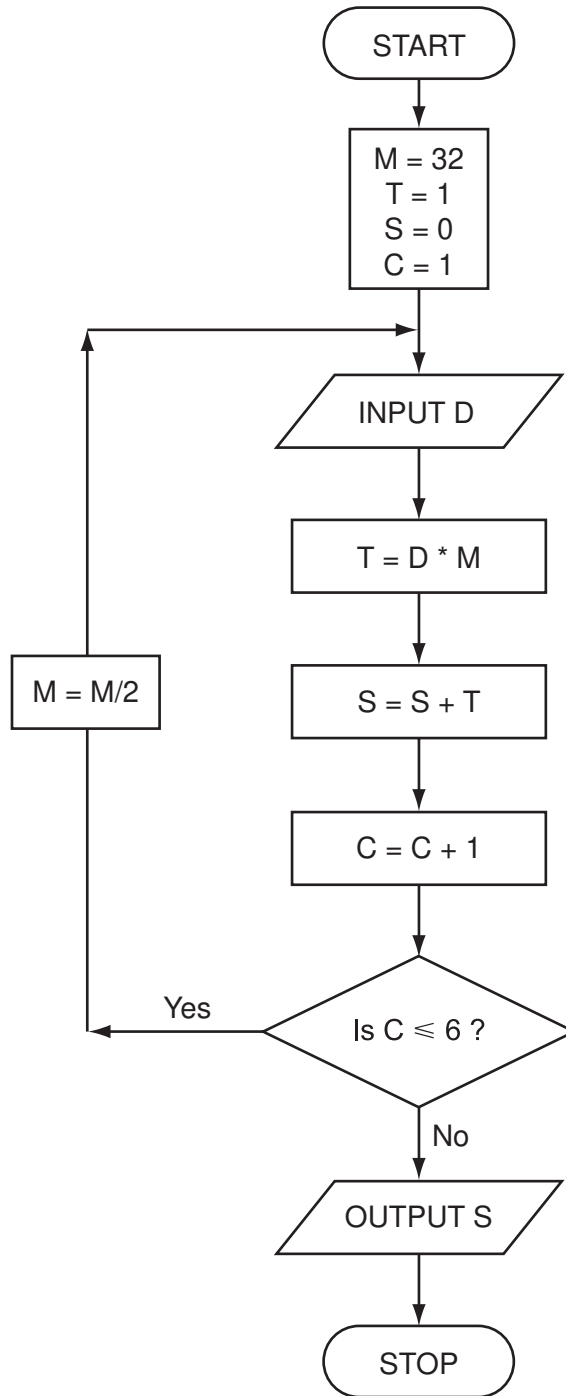

(a) Complete the trace table for the following data:

1, 0, 1, 1, 0, 1

M	T	S	C	D

[4]

(b) What process does this flowchart perform?

.....

 [1]

(c) Predict the output from the flowchart for an input of 1, 1, 1, 1, 0, 0

.....
 [1]

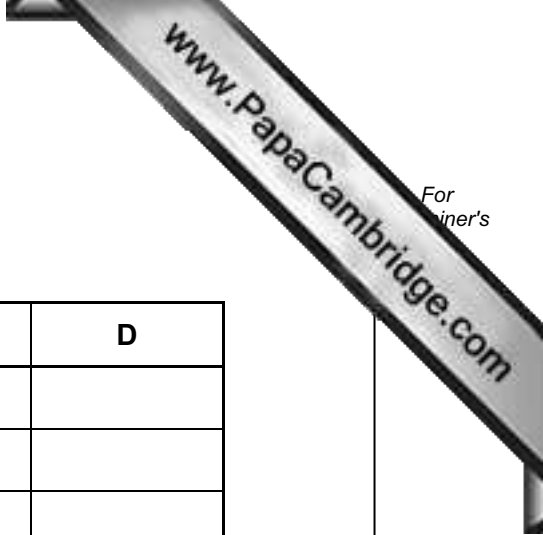

7 An expert system is being developed to diagnose faults in electronic equipment. Each piece of equipment is made up of the following components:

- screen
- keypad (containing F1 to F9 keys)
- sound card and speakers
- RAM and ROM
- microphone

(a) The following series of questions were asked by the expert system. The responses by the user are also shown:

<u>Question</u>	<u>Response</u>
Is the screen operating?	Yes
If the F2 key is pressed, does the screen go green?	Yes
If the F1 key is pressed, can sound output be heard?	No

(i) In which component is the fault likely to be?

.....
 [1]

(ii) What would the expert system do next to help diagnose the exact fault in the component(s)?

.....

 [2]

(iii) What output would the expert system produce?

.....
 [1]

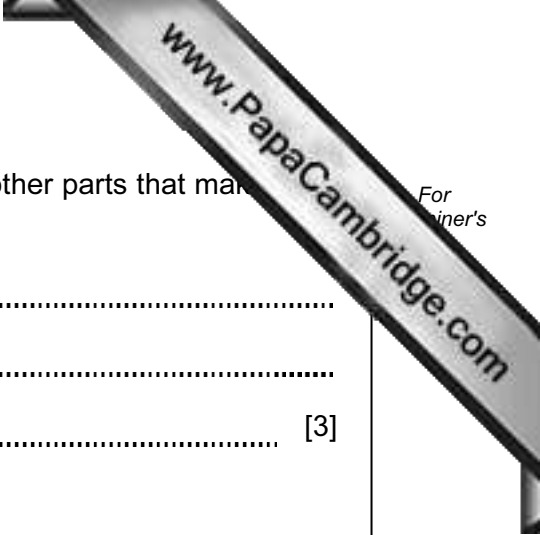

(b) An expert system has an input-output interface. State **three** other parts that make up a typical expert system.

- 1
- 2
- 3 [3]

(c) The electronic equipment contains RAM and ROM.

Give **one** use of each type of memory.

- RAM
-
- ROM
- [2]

8 Body mass index (bmi) is calculated using the following formula:

$$\text{bmi} = \frac{\text{weight}}{(\text{height})^2}$$

Six people's data are shown in the spreadsheet below:

	A	B	C	D	E	F
1	name	weight (kg)	height (m)	bmi	underweight, normal or overweight	
2	Theo	70.0	1.87	20.0		
3	Sujatmi	63.6	2.03	15.4		
4	Angela	72.4	1.70	25.1		
5	Juan	110.0	1.90	30.5		
6	Jatinder	76.4	1.65	28.1		
7	Igor	70.5	1.98	18.0		
8						

(a) What formulas must be in column D to calculate each person's bmi?

	D
1	bmi
2	
3	
4	
5	
6	
7	

[2]

(b) Column E indicates whether the person is underweight, normal or overweight.

(i) The following formula was typed into E2:

= IF(D2<18.5, "underweight", IF(D2>25, "overweight", "normal"))

What output would appear in E2?

..... [1]

(ii) What formula needs to be placed in D8 to find the average (mean) bmi?

.....
..... [1]

(iii) If the formula in E2 were replicated down to E8, what formula would appear in E8?

.....
..... [2]

(c) Column F was added to the spreadsheet to show each person's *ideal weight*. This is calculated using twenty times the square of a person's height.

What formula needs to be placed in F2?

..... [1]

9 (a) Give a suitable application for **each** of the following data capture devices:

barcode reader

.....

radio frequency identification (RFID) reader

.....

magnetic stripe reader

..... [3]

(b) State **two different** validation checks and give an example of their use. Each example should be different.

Check 1

Use

.....

Check 2

Use

..... [4]

- 10 (a) Complete the truth table for the following logic circuit, which is made up of gates:

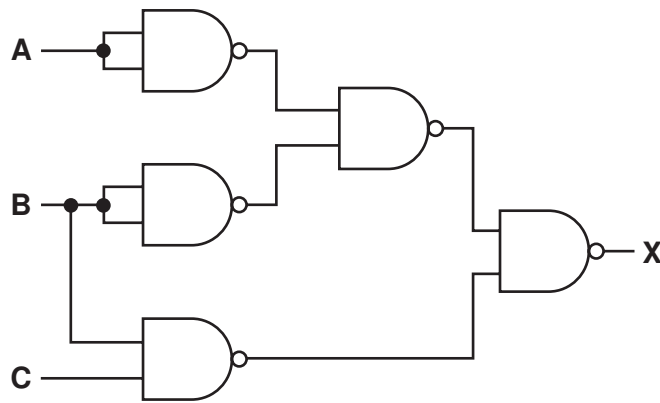

A	B	C	X
0	0	0	
0	0	1	
0	1	0	
0	1	1	
1	0	0	
1	0	1	
1	1	0	
1	1	1	

[4]

(b) Name **two** other types of logic gate and complete their associated truth tables:

Gate 1:

A	B	X
0	0	
0	1	
1	0	
1	1	

Gate 2:

A	B	X
0	0	
0	1	
1	0	
1	1	

[4]

11 A room in a house is fitted with a computerised intruder alarm system:

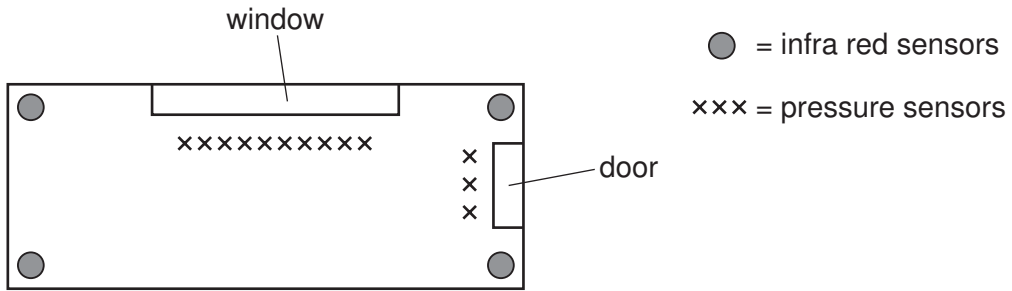

(a) (i) Describe how the sensors and computer would be used to detect intruders.

.....

.....

.....

.....

.....

.....

(ii) Describe how the system warns that an intruder has been detected.

.....

.....

..... [4]

(b) It is decided to automatically close door and window shutters if an intruder is detected.

What additional processing and hardware would be needed?

.....

.....

.....

..... [2]

(c) Name another sensor that could have been used in this intruder alarm system.

.....

..... [1]

(d) What measures could be taken to stop or minimise the number of false alarms?

.....
.....
.....
..... [2]

12 (a) John has bought a 4 Gbyte MP3 player.

(You may assume: 1 byte = 8 bits, 1 Mbyte = 1024 kbytes and 1Gbyte = 1024 Mbytes)

(i) We can assume that each song lasts 3 minutes and is recorded at 128 kbps (kilobits per second).

How much memory is required per song?

.....
.....
.....
..... [2]

(ii) Using your answer in (i), how many songs can be stored on John's MP3 player?

.....
.....
.....
..... [2]

(b) John also bought a device for recording television programmes. It allows him to record a programme *at the same time* as he is watching an earlier recording.

Describe how such a system would work.

.....
.....
.....
.....
.....
..... [3]

13 Look at these two pieces of code:

```

A:      CLC
          LDX #0
loop:    LDA A,X
          ADC B,X
          STA C,X
          INX
          CPX #16
          BNE loop

```

```

B:    FOR Loop = 1 TO 4
          INPUT Number1, Number2
          Sum = Number1 + Number2
          PRINT Sum
        NEXT

```

(a) Which of these pieces of code is written in a high-level language?

..... [1]

(b) Give **one** benefit of writing code in a high-level language.

.....
.....
..... [1]

(c) Give **one** benefit of writing code in a low-level language.

.....
.....
..... [1]

(d) High-level languages can be *compiled* or *interpreted*.

Give **two** differences between a compiler and an interpreter.

1
.....
2
..... [2]

14 A ship at sea uses Global Positioning System (GPS) technology to navigate.

(a) Describe how GPS technology is used to help the ship's navigation.

.....
.....
.....
.....
.....
.....
.....
.....
.....
..... [4]

(b) Describe **two** benefits to the ship's personnel through using GPS technology.

1
.....
.....
2
.....
..... [2]

(c) How should the ship's satnav device give navigation instructions to the ship's personnel?

.....
.....
..... [1]

