

**MARK SCHEME for the October/November 2011 question paper  
for the guidance of teachers**

**0420 COMPUTER STUDIES**

**0420/12**

Paper 1, maximum raw mark 100

This mark scheme is published as an aid to teachers and candidates, to indicate the requirements of the examination. It shows the basis on which Examiners were instructed to award marks. It does not indicate the details of the discussions that took place at an Examiners' meeting before marking began, which would have considered the acceptability of alternative answers.

Mark schemes must be read in conjunction with the question papers and the report on the examination.

- Cambridge will not enter into discussions or correspondence in connection with these mark schemes.

Cambridge is publishing the mark schemes for the October/November 2011 question papers for most IGCSE, GCE Advanced Level and Advanced Subsidiary Level syllabuses and some Ordinary Level syllabuses.

Page 2	Mark Scheme: Teachers' version	Syllabus	
	IGCSE – October/November 2011	0420	

- 1 Any **three** from:
- fact finding
  - feasibility study
  - analysis
  - design
  - testing
  - documentation
  - implementation/changeover/installation
  - evaluation
  - maintenance
- [3]
- 2 (a) Any **one** from:
- file size is small
  - fast to download/upload files
  - format can be played on several types of devices, e.g. mobile phone, CD player, laptop etc.
- [1]
- (b) Any **two** from:
- type of EEPROM
  - non-volatile memories
  - solid state memories
  - NAND based memories
  - mini hard disk drives
- [2]
- 3 Any **three** from:
- data must be up to date
  - data can only be read/used for the purpose for which it was collected
  - data must be accurate/relevant
  - data must be deleted/destroyed when no longer needed/don't keep longer than necessary
  - data must be secure
  - data user must register what data is held
  - data must be used /collected fairly and lawfully
  - data must be protected from accidental damage
  - only authorised people can have access to the data
  - fines will be imposed for data mis-use
  - data should not be passed on to 3rd parties without owner's permission
  - person can view data and have it changed if necessary
- [3]

4

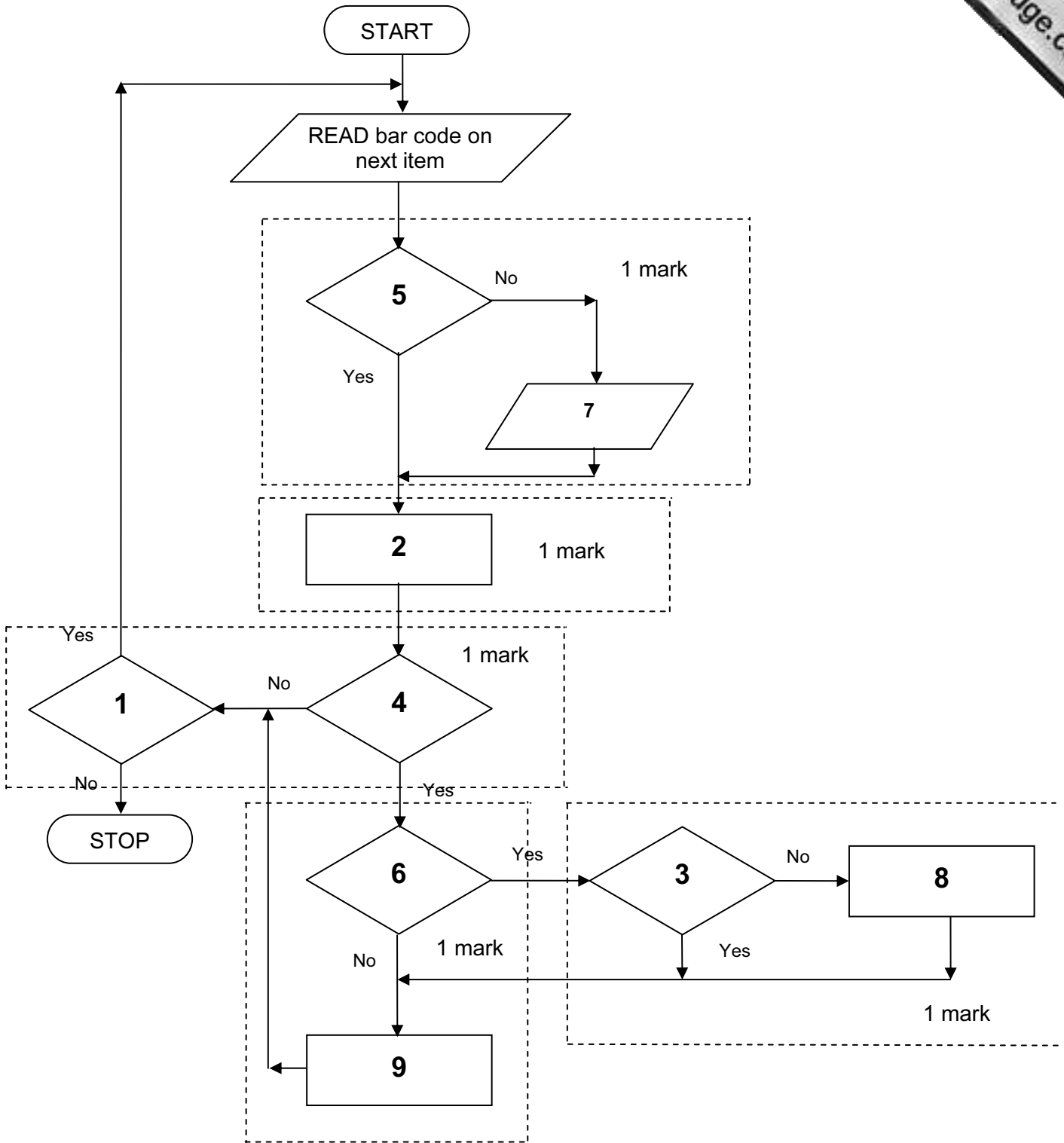

[5]

Page 4	Mark Scheme: Teachers' version	Syllabus	
	IGCSE – October/November 2011	0420	

- 5 (a) Any **one** from:
- software that can be used to design new products/amend existing products
  - makes use of features such as 2D, 3D, wire frames, library of parts, links to CAM
- (b) Any **three** from:
- aerospace
  - architecture
  - designing cars
  - designing consumer goods
  - chemical/nuclear plant design
  - designing electronic circuit boards
  - ergonomic design
  - landscape/garden design
- [3]
- (c) Any **three** from:
- large monitor/screen with hi-res
  - touch screen
  - plotter
  - space mouse/space ball/4D device
  - 3D glasses (in some applications)
  - light pen
  - graphics tablet
  - 3D printer
  - 3D scanner
- [3]
- 6 (a) Any **two** from:
- webcam
  - speakers
  - microphone
  - broadband modem
- [2]
- (b) Any **one** from:
- use of CODEC (converts/compresses analogue data into digital data)
  - echo cancellation s/ware (allows talking in real time/keeps everything in sync)
  - compression s/ware for video/audio
  - s/ware to access broadband/networking
- [1]
- (c) (i) Any **one** from:
- immediate response to questions/queries
  - can see each other watch body language etc.
  - easier to have several participants (would be difficult using instant messaging if several people involved)
  - would take a long time typing out each question
- (ii) Any **one** from:
- need for expensive equipment/high set up costs
  - sometimes synchronisation problems make it difficult for delegates
  - need to train people to use the new technology
  - greater use of bandwidth
- [2]

- (d) Any **one** from:
- faster communications now widely available
  - safety reasons, e.g. increase in terrorist attacks on international flights
  - reduced transportation/accommodation/hardware costs
  - environmental issues, e.g. reduced carbon footprint
  - increase in multinational working

[1]

7 (i)

number	count	temp	total	neg	OUTPUT
7					
	1		0	0	
	2	-5		1	
	3	0		2	
	4	5			
	5	-4		3	
	6	0		4	
	7	10			
	8	-2		5	
					0, 5

<----- 1 mark -----><----- 1 mark -----><----- 1 mark ----->

(ii)

number	count	temp	total	neg	OUTPUT
6					
	1		0	0	
	2	21	21		
	3	20	41		
	4	30	71		
	5	19			
	6	21	92		
	7	15			
					92, 0

<----- 1 mark -----><----- 1 mark -----><----- 1 mark ----->

[6]

Page 6	Mark Scheme: Teachers' version	Syllabus
	IGCSE – October/November 2011	0420

- 8 Any **three** from:
- gather information from experts
  - design the knowledge base
  - create/enter data into the knowledge base
  - design/create the inference engine
  - design/create the rules base
  - develop the input interface/interrogation technique
  - test system fully with known outcomes
  - create structure to relate each item in the knowledge base
  - design method of displaying results
  - expert system shell
- [3]
- 9 (a) (i) = B2/C2
- [1]
- (ii) = AVERAGE(D2:D7) OR  
 = SUM(D2:D7)/6 OR  
 = (D2 + D3 + D4 + D5 + D6 + D7)/6
- [1]
- (iii) = MAX(D2:D7)
- [1]
- (b) D7, D8, D9
- [2]
- (c) = (C7/B7) \* 100
- [2]
- 10 (a) Any **two** from:
- available to those who don't have an Internet connection
  - many people prefer the human contact
  - often better talking to a human/can develop query
  - faster response to a question once connected
  - easier to resolve more complex problems (can take user through steps to solution to problem)
- [2]
- (b) Any **two** from:
- no need to wait in a queue
  - no problem with language/dialect/accent/culture differences
  - open 24-7/can leave question on website any time
  - customer can save/print solution for later referral
  - multimedia services available (e.g. 'How to' videos)
- [2]
- (c) Any **two** from:
- job losses
  - de-skilling
  - need to (re-)train
  - more jobs for technical staff
  - possible job sharing/flexi-hours/working from home
- [2]

Page 7	Mark Scheme: Teachers' version	Syllabus
	IGCSE – October/November 2011	0420

- 11 (a) (i) Any **one** from:
- unit of data/memory
  - 8 bits
  - used to represent a character

- (ii) Any **one** from:
- $2^{30}$  bytes
  - 1 073 741 824 bytes
  - 1 048 576 kilobytes
  - 1024 megabytes

[1]

- (b) Any **two** from:

Flash memory

- magnetic media/solid state memory
- no formatting issues
- plugs directly into the USB port
- direct transfer of data

CD-RW

- optical media
- slower access speed/flash memory has faster access speed
- requires a separate drive
- data needs to be burnt/finalised/finished (before being used on another device)

[2]

- 12 (a) Only answers:

- temperature (sensor)
- oxygen (sensor)

[2]

- (b) Any **four** from:

- information from the sensors sent to microprocessor
- the ADC converts the analogue data into digital form
- if temperature  $< 25^{\circ}\text{C}$  OR temperature checked against stored value
- ...microprocessor sends signal to heater/actuator/valve...
- ...to switch on heater
- if oxygen level  $< 20$  ppm OR oxygen level checked against stored value
- ...to open valve/oxygen supply
- use of DAC between microprocessor and devices
- sounds an alarm if system unable to respond
- continuously monitors sensor inputs
- any reference to feedback

[4]

- (c) Any **one** from:

- unsafe limit stored in memory
- warning sound/signal if too high a value reached
- fail safe switch off in case of a malfunction

[1]

13 (a) Any **four** from:

- satellites transmit signals to onboard computers
- computers receive/interpret these signals
- system depends on very accurate timing/use of atomic clocks
- each satellite transmits data indicating location and time
- computer in aeroplane calculates location based on at least three satellites
- at least 24 satellites in operation at any one time
- position accurate to within one metre
- can also calculate altitude of aeroplane
- ref to "triangulation":

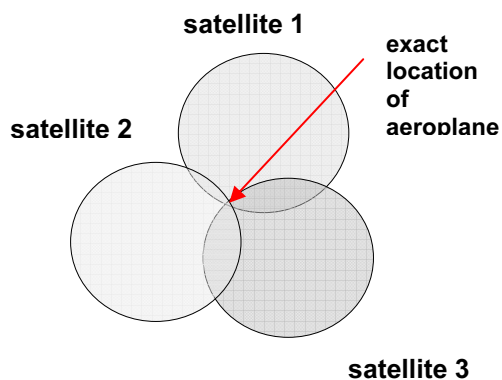

[4]

(b) Any **two** from:

- safer as known location is exact/more accurate
- reduces possibility of pilot error
- allows accurate estimation of arrival time
- display and guide pilot to nearest airport in case of emergency

[2]

14 (a) **1 mark** for **each** correct logic gate:

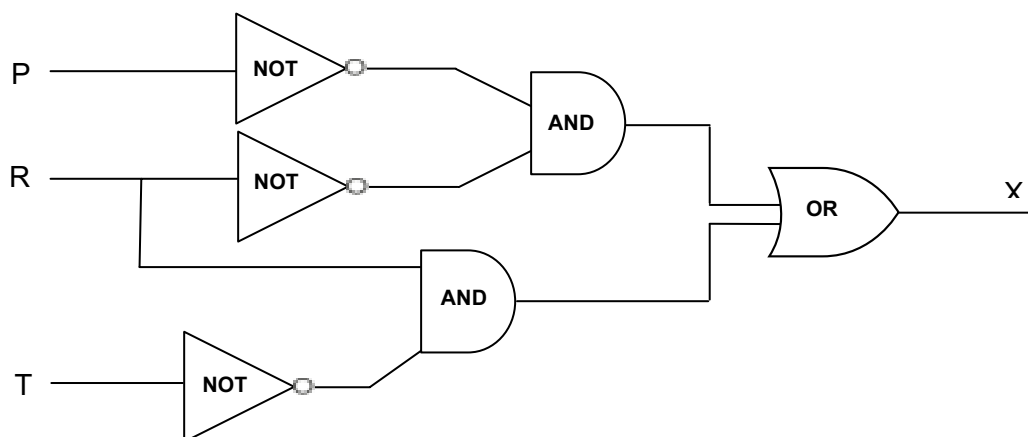

[6]



(b)

P	R	T	X
0	0	0	1
0	0	1	1
0	1	0	1
0	1	1	0
1	0	0	0
1	0	1	0
1	1	0	1
1	1	1	0

] 1 mk  
 ] 1 mk  
 ] 1 mk  
 ] 1 mk

[4]

15 (a) 1 mark for the correct working in BOTH parts  
 1 mark for valid  
 1 mark for not valid

(i) working

$$\begin{aligned}
 &= (4 \times 6) + (2 \times 5) + (1 \times 4) + (9 \times 3) + (2 \times 2) + (3 \times 1) \\
 &= 24 + 10 + 4 + 27 + 4 + 3 \\
 &= 72 \div 11 \\
 &= 6 \text{ remainder } 6 \\
 &\text{valid/not valid: NOT valid}
 \end{aligned}$$

(ii) working

$$\begin{aligned}
 &= (8 \times 6) + (2 \times 5) + (0 \times 4) + (1 \times 3) + (5 \times 2) + (6 \times 1) \\
 &= 48 + 10 + 0 + 3 + 10 + 6 \\
 &= 77 \div 11 \\
 &= 7 \text{ remainder } 0 \\
 &\text{valid/not valid: VALID}
 \end{aligned}$$

[3]

(b) 1 mark for correct working + 1 mark for check digit

working

$$\begin{aligned}
 &= (5 \times 6) + (0 \times 5) + (2 \times 4) + (4 \times 3) + (1 \times 2) \\
 &= 30 + 0 + 8 + 12 + 2 \\
 &= 52
 \end{aligned}$$

need to add 3 to make the total 55 (i.e. exactly divisible by 11)

check digit: 3

[2]

(c) 2 digits transposed

(e.g. 280419 becomes 280149/ two digits have been switched)  
 incorrect digit

(e.g. 280419 becomes 250419/ one of the digits has been mistyped)

[2]

Page 10	Mark Scheme: Teachers' version	Syllabus
	IGCSE – October/November 2011	0420

16 (a) Any **two** from:

- lock the room/computer
- use/prevent use of removable storage media
- passwords and/or ids (to get into the system)
- log off when computer not attended
- encrypt data

[2]

(b) 1 mark for each risk + 1 mark for associated protection method.

risk: virus  
protection: use ant-virus software

risk: hacking  
protection: passwords/ids  
firewalls

risk: use of wifi systems  
protection: passwords/ids  
firewalls

risk: phishing:  
protection: don't open websites from "unknown" emails  
anti-phishing software

risk: pharming:  
protection: check certification of website under properties  
check spelling of websites  
use a well respected ISP

[4]

(c) (i)

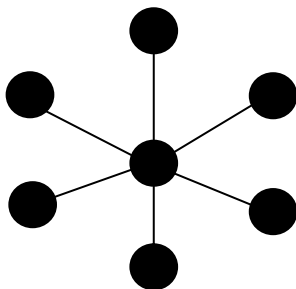

[1]

(ii) Any **one** from:

- if one station/cable fails, others are not affected
- easier to identify faults when using star topologies
- it is easier to expand this type of network
- performance doesn't deteriorate under load

[1]

Page 11	Mark Scheme: Teachers' version	Syllabus
	IGCSE – October/November 2011	0420

- (d) Any **two** from:
- processor should consume as little power as possible (thus prolonging the battery)
  - processor should run as cool as possible (minimising problems associated with dissipation)
  - no fans needed to cool processor (thus reducing the load on the internal battery) [2]

- 17 (a) marking points:
- the way to find and print the largest value a 1 mark
  - the way to find and print the largest value b 1 mark
  - the way to find and print the largest value c 1 mark

sample algorithm:

```
input a, b, c
  if a > b and a > c then print a (1 mark)
    else if b > c then print b (1 mark)
      else print c (1 mark)
```

[3]

- (b) marking points:
- loop construct 1 mark
  - check if number is an *integer* 1 mark
  - counting the number of integers input 1 mark
  - output count value (outside the loop) 1 mark

sample algorithm:

```
for x = 1 to 1000 (1 mark)
  input number
    difference = INT(number) – number (1 mark)
    if difference = 0 then total = total + 1 (1 mark)
next x
print total (1 mark)
(NOTE: alternative to lines 3 and 4:
if INT(number) = number then total = total + 1 (2 marks) )
```

[4]