

CANDIDATE
NAME

CENTRE
NUMBER

| | | | | |
|--|--|--|--|--|
| | | | | |
|--|--|--|--|--|

CANDIDATE
NUMBER

| | | | |
|--|--|--|--|
| | | | |
|--|--|--|--|

MATHEMATICS

0580/31

Paper 3 (Core)

May/June 2015

2 hours

Candidates answer on the Question Paper.

Additional Materials: Electronic calculator
 Tracing paper (optional)

Geometrical instruments

READ THESE INSTRUCTIONS FIRST

Write your Centre number, candidate number and name on all the work you hand in.

Write in dark blue or black pen.

You may use an HB pencil for any diagrams or graphs.

Do not use staples, paper clips, glue or correction fluid.

DO NOT WRITE IN ANY BARCODES.

Answer **all** questions.

If working is needed for any question it must be shown below that question.

Electronic calculators should be used.

If the degree of accuracy is not specified in the question, and if the answer is not exact, give the answer to three significant figures. Give answers in degrees to one decimal place.

For π , use either your calculator value or 3.142.

At the end of the examination, fasten all your work securely together.

The number of marks is given in brackets [] at the end of each question or part question.

The total of the marks for this paper is 104.

The syllabus is approved for use in England, Wales and Northern Ireland as a Cambridge International Level 1/Level 2 Certificate.

This document consists of **15** printed pages and **1** blank page.

1 (a) Write down

(i) two factors of 12,

Answer(a)(i) [1]

(ii) the next prime number after 19,

Answer(a)(ii) [1]

(iii) the cube root of 64,

Answer(a)(iii) [1]

(iv) two million five hundred and seven in figures,

Answer(a)(iv) [1]

(v) two multiples of 75,

Answer(a)(v) [1]

(vi) the value of π correct to 5 significant figures.

Answer(a)(vi) [1]

(b) Write as a percentage.

(i) 1.63

Answer(b)(i) % [1]

(ii) $\frac{3}{40}$

Answer(b)(ii) % [1]

(c) (i) Write 63 521.769 correct to 1 decimal place.

Answer(c)(i) [1]

(ii) Write 63 521.769 correct to the nearest hundred.

Answer(c)(ii) [1]

(d) (i) Change 234 mm into metres.

Answer(d)(i) m [1]

(ii) Change 876 m^2 into square centimetres.

Answer(d)(ii) cm^2 [1]

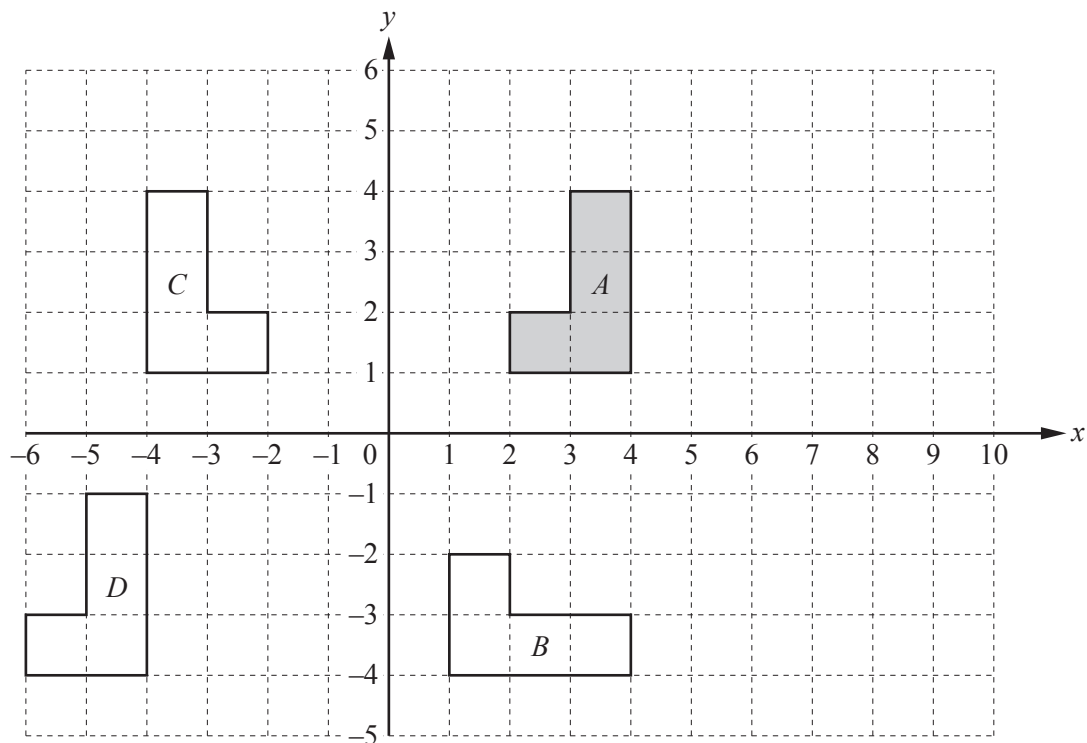

The diagram shows four shapes *A*, *B*, *C* and *D*.

(a) Describe fully the **single** transformation that maps **shape A** onto

(i) shape *B*,

Answer(a)(i)
 [3]

(ii) shape *C*,

Answer(a)(ii)
 [2]

(iii) shape *D*.

Answer(a)(iii)
 [2]

(b) On the grid, draw the enlargement of **shape A** by scale factor 2 and centre $(-1, 2)$. [2]

3 Sonia works in a toy shop.

(a) (i) One week she works for 30 hours and is paid \$180.

Calculate the amount she is paid per hour.

Answer(a)(i) \$ [1]

(ii) The next week Sonia works for 38 hours and is paid \$220.

Find the difference in her pay per hour for these two weeks.

Answer(a)(ii) \$ [2]

(b) The shop sells bags of 40 marbles.

One bag has marbles in the ratio red : blue : green = 1 : 3 : 4.

(i) Calculate the number of marbles of each colour.

Answer(b)(i) Red = , blue = , green = [2]

(ii) A second bag of 40 marbles contains 11 red marbles, 9 blue marbles and 20 green marbles.

All the marbles from the two bags are mixed together.

Write down the ratio of marbles red : blue : green.

Give your answer in its simplest form.

Answer(b)(ii) : : [2]

- (c) Thilo and Toby buy some boats and trains from the toy shop.
The cost of one boat is b cents and the cost of one train is t cents.

- (i) Toby buys 3 boats and 4 trains for \$5.70 .

Complete this equation.

$$3b + 4t = \dots\dots\dots$$

[1]

- (ii) Thilo buys 1 boat and 2 trains for \$2.40 .

Write this information as an equation.

$$\dots\dots\dots = \dots\dots\dots$$

[2]

- (iii) Solve your two equations to find the cost of a boat and the cost of a train.
You must show all your working.

Answer(c)(iii) Cost of a boat = $\dots\dots\dots$ cents

Cost of a train = $\dots\dots\dots$ cents [3]

- (d) Train track costs 99 cents per 20 cm.

Calculate the cost of buying 3.4 metres of train track.

Answer(d) \$ $\dots\dots\dots$ [3]

4 The Patel family flies from their home town, H , to Kiruna, K , in Lapland.

- (a) The scale drawing shows their journey.
The scale is 1 centimetre represents 40 kilometres.

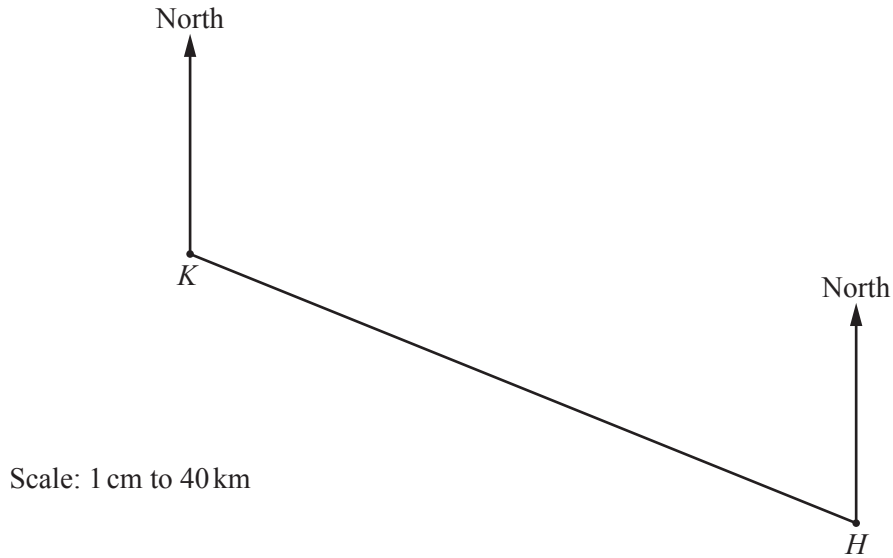

- (i) Measure the bearing of K from H .

Answer(a)(i) [1]

- (ii) Work out the distance in kilometres from H to K .

Answer(a)(ii) km [2]

- (iii) The average speed of the plane is 450 km/h.

Find the average speed in m/s.

Answer(a)(iii) m/s [2]

- (b) The probability that the plane arrives on time is 0.15 .

- (i) Write down the probability that the plane does **not** arrive on time.

Answer(b)(i) [1]

- (ii) Every year there are 240 flights from H to K .

Calculate the expected number of flights that arrive on time.

Answer(b)(ii) [1]

- (c) The Patel family has six suitcases.
The number of items in each suitcase is shown below.

15 16 16 18 19 21

- (i) Find the range.

Answer(c)(i) [1]

- (ii) Write down the mode.

Answer(c)(ii) [1]

- (iii) Work out the median.

Answer(c)(iii) [1]

- (iv) Calculate the mean.

Answer(c)(iv) [2]

- (v) Find the probability that a suitcase chosen at random has more than 18 items.

Answer(c)(v) [1]

- (d) Mr Patel buys a bag of sweets.
The bag of sweets costs \$3.25 .

- (i) Calculate the cost of the sweets in euros (€) when the exchange rate is $\text{€}1 = \$1.24$.

Answer(d)(i) €..... [2]

- (ii) The weight, w grams, of the bag of sweets is 250 g correct to the nearest 10 g.

Complete this statement about the value of w .

Answer(d)(ii) $\leq w <$ [2]

- 5 All the children in a school are asked to choose their favourite colour. The pie chart shows the results.

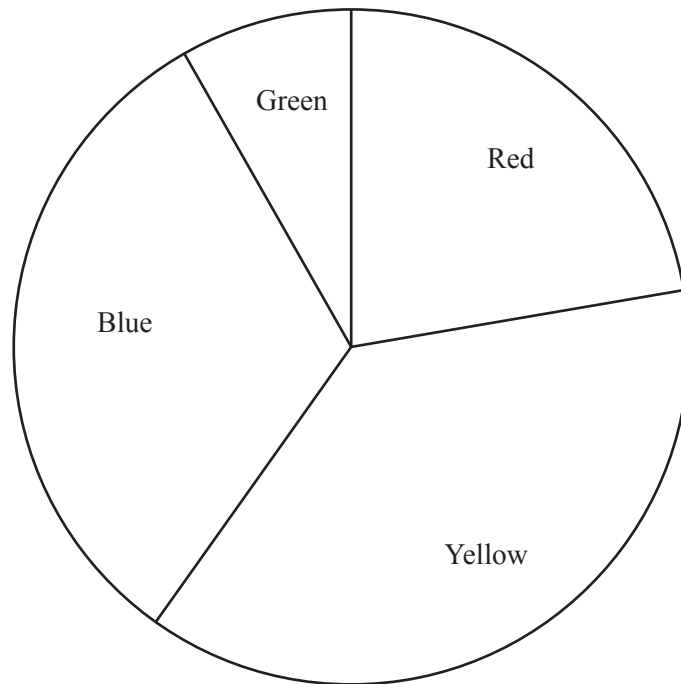

- (a) Write down the least favourite colour chosen.

Answer(a) [1]

- (b) 27 children choose yellow as their favourite colour.

Work out the total number of children in the school.

Answer(b) [3]

- (c) Work out the percentage of the children in the school who choose red.

Answer(c) % [2]

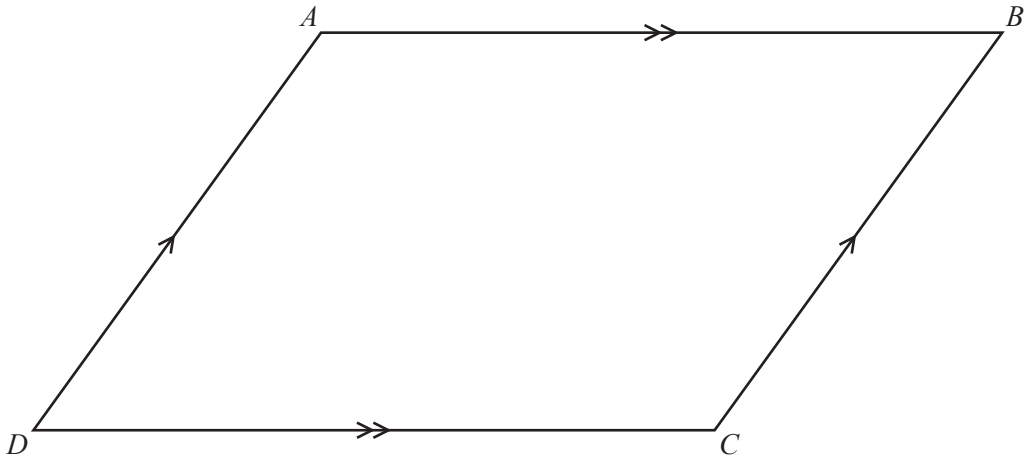

$ABCD$ is a parallelogram.

(a) Write down

(i) the order of rotational symmetry of $ABCD$,

Answer(a)(i) [1]

(ii) the number of lines of symmetry of $ABCD$,

Answer(a)(ii) [1]

(iii) the sum of the interior angles of $ABCD$.

Answer(a)(iii) [1]

(b) (i) Complete this part using a straight edge and compasses only.
All construction arcs must be clearly shown.

On the diagram, construct the bisector of angle BAD .

Extend this bisector to cut DC at E . Mark E on your diagram.

[2]

(ii) Edelgard knows that angle BAE is the same size as angle AED .

Explain how Edelgard knows this is true without measuring the angles.

Answer(b)(ii) [1]

(iii) Write down the mathematical name for the triangle ADE and give a reason for your answer.

Answer(b)(iii) Name because

..... [2]

(iv) Write down the mathematical name of the quadrilateral $ABCE$.

Answer(b)(iv) [1]

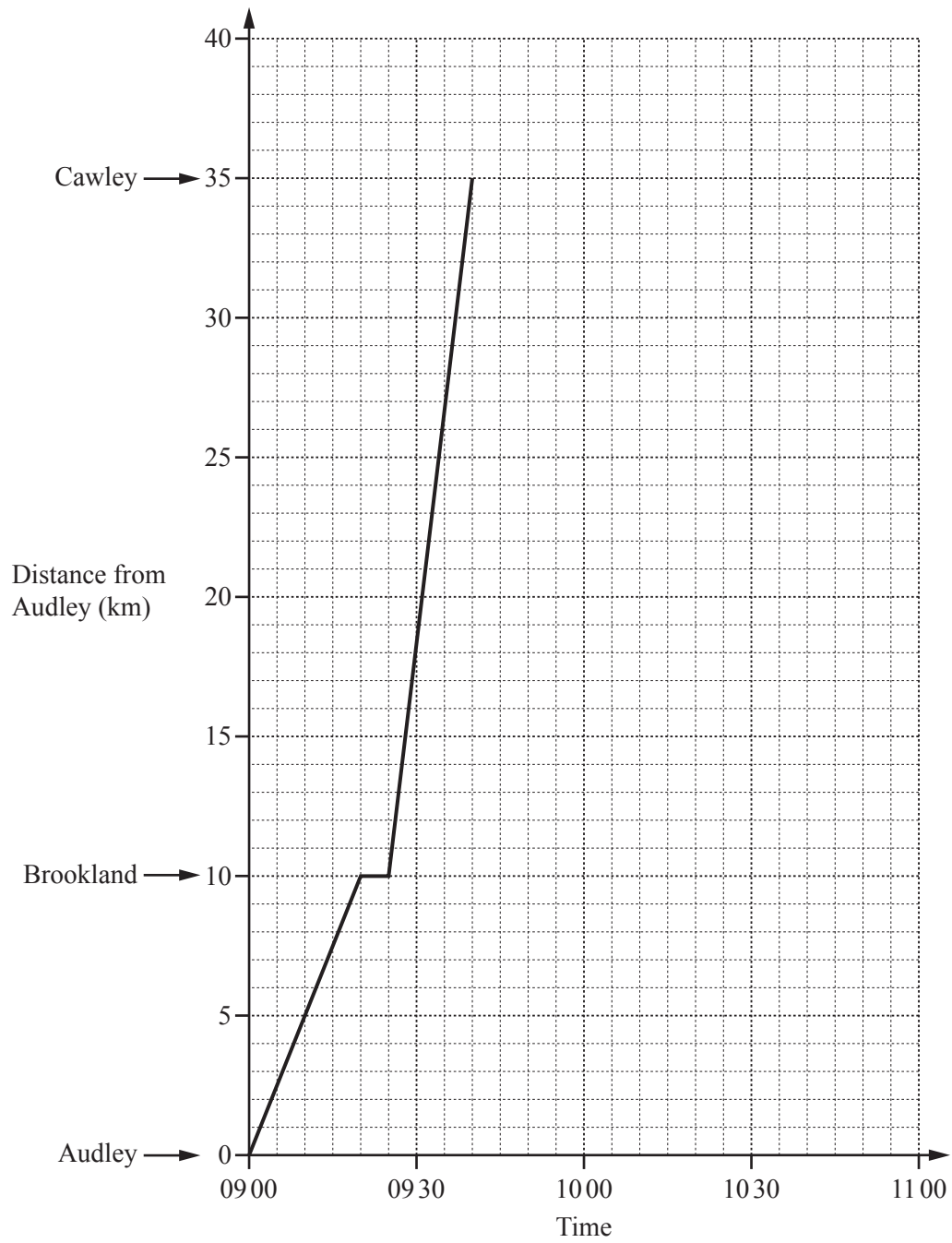

The grid shows the travel graph for a train travelling from Audley to Cawley, stopping at Brookland.

- (a) (i)** Between which two towns is the train journey fastest?
Give a reason for your answer.

Answer(a)(i) From to is fastest because
..... [1]

- (ii)** Calculate the speed of the train, in kilometres per hour, between Brookland and Cawley.

Answer(a)(ii) km/h [2]

- (b)** When the train reaches Cawley, it waits for 10 minutes.
It then returns to Audley without stopping at Brookland.
The return speed of the train is 70 km/h.

- (i)** Complete the travel graph for this train. [2]

- (ii)** Write down the time this train arrives at Audley.

Answer(b)(ii) [1]

- (c)** Trains leave Audley for Cawley every 100 minutes.
The first train of the day is the 09 00 train.

Write down the time that the fourth train leaves Audley for Cawley.

Answer(c) [2]

8 (a)

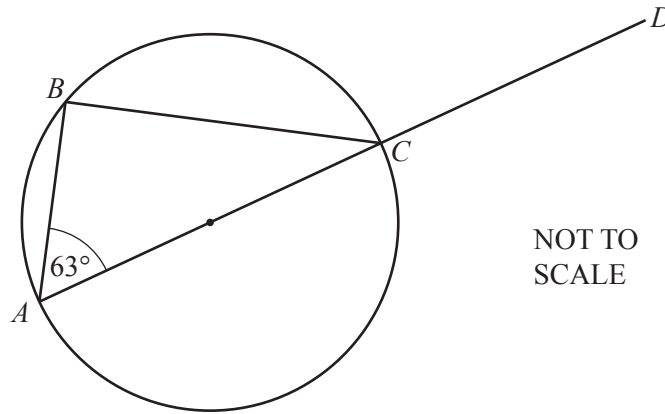

A, B and C lie on a circle with diameter AC .
 AC is extended to D and angle $BAC = 63^\circ$.

Work out angle BCD .
 Give reasons to explain your answer.

Answer(a) Angle $BCD = \dots\dots\dots$ because $\dots\dots\dots$
 $\dots\dots\dots$
 $\dots\dots\dots$ [4]

(b)

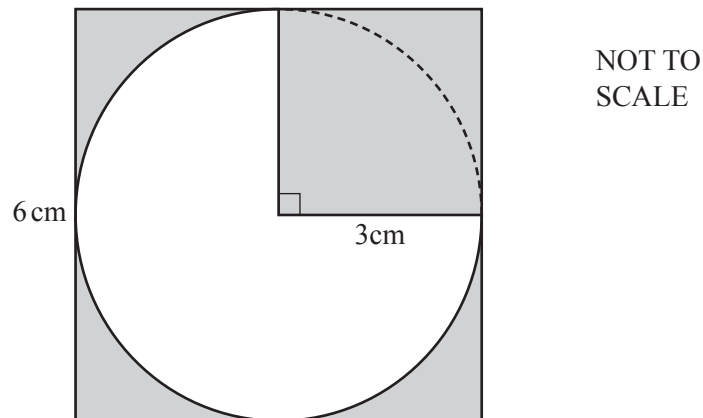

The diagram shows a circle with radius 3 cm inside a square of side 6 cm.
 Calculate the shaded area.

Answer(b) $\dots\dots\dots$ cm² [5]

(c)

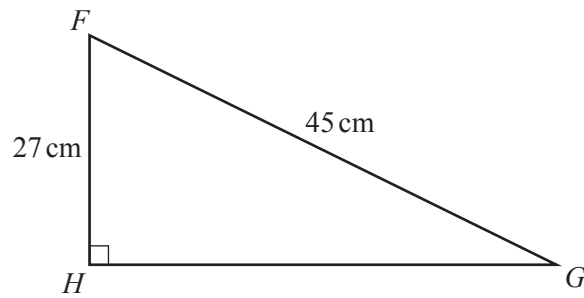
NOT TO
SCALE

FGH is a right-angled triangle.

Calculate

(i) GH ,

Answer(c)(i) $GH = \dots\dots\dots$ cm [3]

(ii) the perimeter of the triangle,

Answer(c)(ii) $\dots\dots\dots$ cm [1]

(iii) the area of the triangle.

Answer(c)(iii) $\dots\dots\dots$ cm² [2]

9 (a) (i) Complete the table of values for $y = -x^2 + 5x$.

| | | | | | | | | |
|-----|----|---|---|---|---|---|---|---|
| x | -1 | 0 | 1 | 2 | 3 | 4 | 5 | 6 |
| y | -6 | | 4 | | | 4 | 0 | |

[2]

(ii) On the grid, draw the graph of $y = -x^2 + 5x$ for $-1 \leq x \leq 6$.

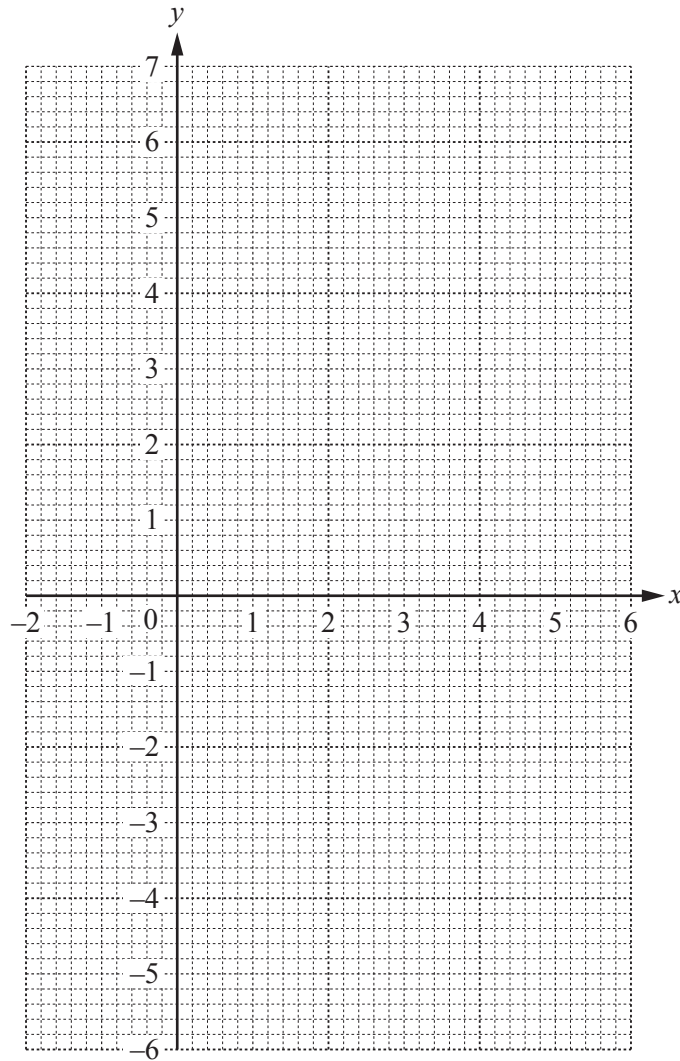

[4]

(b) Write down the co-ordinates of the highest point on the graph.

Answer(b) (.....,) [1]

(c) Use your graph to solve the equation $-x^2 + 5x = -3$.

Answer(c) $x = \dots\dots\dots$ or $x = \dots\dots\dots$ [2]

(d) (i) On the grid, draw the line of symmetry for the graph. [1]

(ii) Write down the equation of the line of symmetry for the graph.

Answer(d)(ii) $\dots\dots\dots$ [1]

(iii) The curve passes through the points $(-10, -150)$ and $(k, -150)$.

Use the symmetry of the curve to find the value of k .

Answer(d)(iii) $k = \dots\dots\dots$ [1]

BLANK PAGE

Permission to reproduce items where third-party owned material protected by copyright is included has been sought and cleared where possible. Every reasonable effort has been made by the publisher (UCLES) to trace copyright holders, but if any items requiring clearance have unwittingly been included, the publisher will be pleased to make amends at the earliest possible opportunity.

To avoid the issue of disclosure of answer-related information to candidates, all copyright acknowledgements are reproduced online in the Cambridge International Examinations Copyright Acknowledgements Booklet. This is produced for each series of examinations and is freely available to download at www.cie.org.uk after the live examination series.

Cambridge International Examinations is part of the Cambridge Assessment Group. Cambridge Assessment is the brand name of University of Cambridge Local Examinations Syndicate (UCLES), which is itself a department of the University of Cambridge.