



Cambridge International Examinations
Cambridge International General Certificate of Secondary Education

CANDIDATE
NAME

--

CENTRE
NUMBER

--	--	--	--	--

CANDIDATE
NUMBER

--	--	--	--

INFORMATION AND COMMUNICATION TECHNOLOGY

0417/11

Paper 1

May/June 2015

2 hours

Candidates answer on the Question Paper.

No Additional Materials are required.

READ THESE INSTRUCTIONS FIRST

Write your Centre number, candidate number and name on all the work you hand in.

Write in dark blue or black pen.

You may use an HB pencil for any diagrams, graphs or rough working.

Do not use staples, paper clips, glue or correction fluid.

DO **NOT** WRITE IN ANY BARCODES.

No marks will be awarded for using brand names of software packages or hardware.

Answer **all** questions.

At the end of the examination, fasten all your work securely together.

The number of marks is given in brackets [] at the end of each question or part question.

This document consists of **13** printed pages and **3** blank pages.

1300317647



- 1 This diagram shows a laptop computer being used in a measuring experiment.

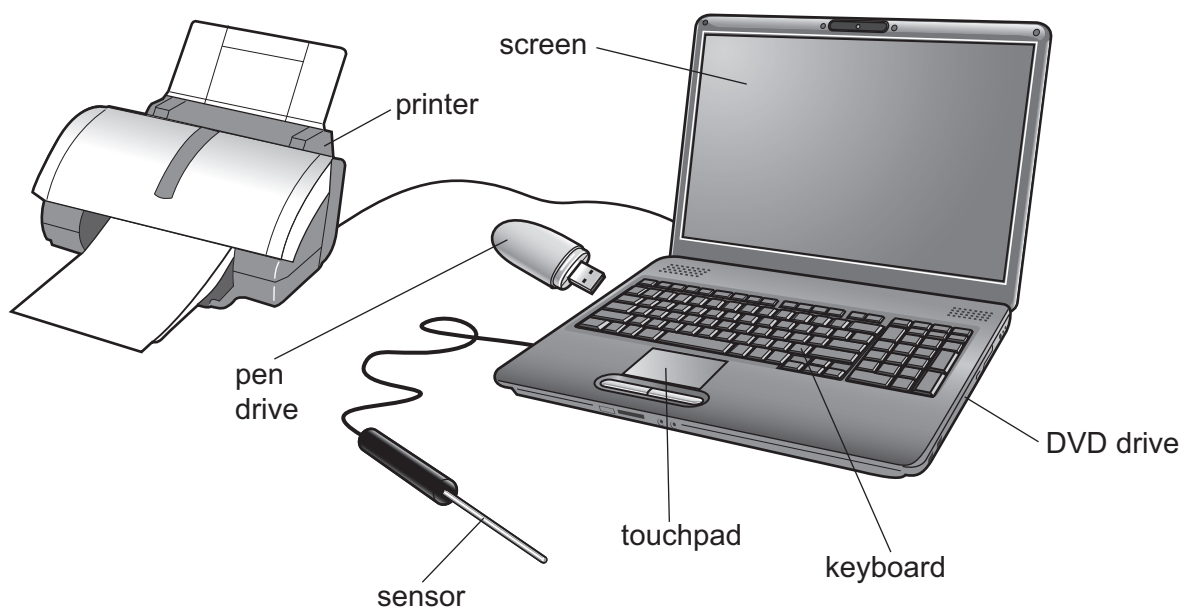

- (a) Apart from the keyboard, name **two** input devices shown in the diagram above.

1..... [2]
 2..... [2]

- (b) Name **two** output devices shown in the diagram above.

1..... [2]
 2..... [2]

- (c) Name **two** storage devices shown in the diagram above.

1..... [2]
 2..... [2]

- 2 Tick the **most** appropriate method of inputting data for the following uses.

Use	MICR ✓	Trackerball ✓	Sensor ✓
Reading data from a cheque			
Inputting the temperature of a greenhouse			
People with limited motor skills using computers			
Inputting the amount of humidity in a weather station			

[4]

- 3 Complete the table by identifying the **most** appropriate output device for each type of application.

Application	Device
Produces very high quality printing where speed is not an issue	
Production of continuous stationery where noise is not an issue	
Produces rapid, high quality and high volume printing	
Produces very large printouts such as size A0	

[4]

- 4 Tick which of these statements apply to a Blog, a Microblog or a Wiki.

	Blog ✓	Microblog ✓	Wiki ✓
Very restricted on the size of post			
Allows readers to edit posts			
Entries are not usually in chronological order			
Very difficult to customise			

[4]

- 5 Complete each of the sentences using the **most** appropriate word from the list below.

batch **sensor** **OCR**
fan **MICR** **direct**
serial **motor**

- (a) The type of processing used for processing bank cheques is called [1]
- (b) The type of access used on a magnetic hard disc is called [1]
- (c) An item of hardware which is used to open windows is called a [1]

6 A floor turtle can use the following instructions:

INSTRUCTION	MEANING
FORWARD n	Move n mm forward
BACKWARD n	Move n mm backward
LEFT t	Turn left t degrees
RIGHT t	Turn right t degrees
PENUP	Lift the pen
PENDOWN	Lower the pen
REPEAT n	Repeat the following instructions n times
END REPEAT	Finish the REPEAT loop

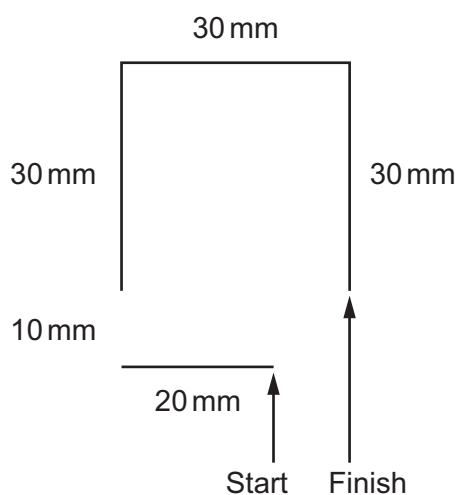

Complete the set of instructions to draw this shape by filling in the blank lines. Do **not** use additional lines.

PENDOWN

LEFT 90

FORWARD 20

RIGHT 90

PENUP

..... FORWARD 30

[6]

7 A home is fitted with a microprocessor-controlled burglar alarm system. It is not connected to a police station.

(a) Tick **three** sensors which would be used in such a system.

	✓
Pressure sensor	
Oxygen level sensor	
Wind speed sensor	
Sound sensor	
Body sensor	
Moisture sensor	
Infra-red sensor	
Touch sensor	

[3]

(b) Describe how a microprocessor-controlled burglar alarm system operates, referring to those sensors you identified in part (a).

.....

.....

.....

.....

.....

.....

.....

.....

.....

.....

.....

.....

.....

.....

.....

.....

.....

.....

.....

.....

.....

.....

[5]

8 The owner of a sports club has recently had a new computerised stock control system installed. He employed a systems analyst to research the existing system and then install the new system.

(a) Tick the relevant stage of the systems analysis and design (systems life cycle) for each of the following activities.

Activity	Analysis ✓	Design ✓	Evaluation ✓
Interviewing the users of the new system			
Interviewing the users of the existing system			
Planning the validation routines			
Examining existing documents			

[4]

(b) Before the system was installed, the systems analyst had to decide on a method of implementation.

Name and describe **three** methods of implementation.

Name

Description

.....

Name

Description.....

.....

Name.....

Description

.....

[6]

(c) When the system was implemented, the system analyst gave some documentation to the sports club owner.

Name **three** items found in the technical documentation of this system.

1.

.....

2.

.....

3.

.....

[3]

(d) Name **three** items in the user documentation which are not present in the technical documentation.

1.

.....

2.

.....

3.

.....

[3]

- 9 A headteacher wants to store details of his students' attendances in a spreadsheet. He has typed in the details of two students so far. Each student is identified by a student ID which consists of one letter followed by 6 digits. The number of possible attendances is recorded along with each student's actual number of attendances.

	A	B	C	D	E
1	Student name	Student ID	Possible attendances	Actual attendances	
2					
3	Maria Gonzales	L543789	80	72	
4	Clive Lloyd	M351209	80	66	
5					
6					

- (a) The headteacher wants to ensure the Student ID is accurately entered.

Describe a method of verifying the input.

.....

.....

.....

..... [2]

- (b) He wants the spreadsheet to perform a calculation of the percentage attendance of Maria Gonzales in E3.

Explain how he would use the spreadsheet to do this.

.....

.....

.....

..... [2]

(c) He now wants to add another 18 students to the spreadsheet.

Explain how he could calculate the percentage attendance for each student by only using a computer mouse.

.....

.....

.....

.....

.....

.....

[3]

(d) Give **two** reasons, apart from cost, why computer models are often used instead of the real thing.

1.

.....

2.

.....

[2]

10 Tick **four** drawbacks to car manufacturers of introducing robots on production lines.

	✓
Redundancy payments to previous workers are expensive	
The cars produced are not of a consistent standard	
Robots are unable to think for themselves	
Robots do not go on strike	
Robots are expensive to buy	
Mistakes are never made	
Maintaining robots costs money	
Car workers have to be paid more	

[4]

11 (a) Explain what is meant by Spam.

.....
.....
.....
..... [2]

(b) Describe how web pages can be used to trick users into giving personal information.

.....
.....
.....
.....
.....
.....
.....
..... [4]

12 Alfonso's family has three computers. He wants each member of his family to be able to access internet shopping.

(a) Identify **three** items of hardware he may need to purchase in order to set up a computer network that will enable this to happen.

1.
2.
3. [3]

(b) Alfonso's teenage daughter uses her computer to create and send work to school.

Describe **three** other ways she could make appropriate use of the internet.

1.
.....
2.
.....
3.
..... [3]

(c) Describe a strategy that Alfonso’s daughter could use to back up her school work.

.....
.....
.....
..... [2]

(d) The bank that Alfonso uses only requires customers to log into their account by inputting a user id and password.

Explain why this is not very secure and discuss other ways the bank could identify the customer securely.

.....
.....
.....
.....
.....
.....
.....
.....
.....
.....
.....
.....
.....
.....
.....
.....
.....
.....
..... [6]

13 Ahmed has asked Anna, a systems analyst, to create a new database system for his video rental business. He rents out films in DVD and Blu-ray formats only. Here are some of the questions customers ask:

1. Do you have the film 'Muppets most wanted' in Blu-ray format?
2. Do you have any films which I can rent for less than \$3?
3. Do you have any films directed by Stephen Spielberg?

(a) Complete the design table below by filling in the field names and data types. Use the **most** appropriate data type to create a database which would answer the questions shown above. Do not use spaces in field names.

Field name	Data type
Film_title	
Name_of_director	

[6]

(b) Describe how Ahmed would use the finished database to produce a report, without using word processing software, to answer the second question above.

.....

.....

.....

.....

.....

.....

.....

.....

.....

.....

[4]

- 14 A lending library has introduced an e-book borrowing facility. Borrowers will be able to download a book to their tablet computer or e-book reader. It will automatically remove itself from the device after the loan period has expired.

Discuss the advantages and disadvantages of such a system to the library and the borrower.

.....

.....

.....

.....

.....

.....

.....

.....

.....

.....

.....

.....

.....

.....

.....

.....

[6]

BLANK PAGE

BLANK PAGE

BLANK PAGE

Permission to reproduce items where third-party owned material protected by copyright is included has been sought and cleared where possible. Every reasonable effort has been made by the publisher (UCLES) to trace copyright holders, but if any items requiring clearance have unwittingly been included, the publisher will be pleased to make amends at the earliest possible opportunity.

To avoid the issue of disclosure of answer-related information to candidates, all copyright acknowledgements are reproduced online in the Cambridge International Examinations Copyright Acknowledgements Booklet. This is produced for each series of examinations and is freely available to download at www.cie.org.uk after the live examination series.

Cambridge International Examinations is part of the Cambridge Assessment Group. Cambridge Assessment is the brand name of University of Cambridge Local Examinations Syndicate (UCLES), which is itself a department of the University of Cambridge.