

**CAMBRIDGE INTERNATIONAL EXAMINATIONS**

Cambridge International General Certificate of Secondary Education

## **MARK SCHEME for the May/June 2015 series**

### **0478 COMPUTER SCIENCE**

**0478/12**

Paper 1 (Written), maximum raw mark 75

This mark scheme is published as an aid to teachers and candidates, to indicate the requirements of the examination. It shows the basis on which Examiners were instructed to award marks. It does not indicate the details of the discussions that took place at an Examiners' meeting before marking began, which would have considered the acceptability of alternative answers.

Mark schemes should be read in conjunction with the question paper and the Principal Examiner Report for Teachers.

Cambridge will not enter into discussions about these mark schemes.

Cambridge is publishing the mark schemes for the May/June 2015 series for most Cambridge IGCSE<sup>®</sup>, Cambridge International A and AS Level components and some Cambridge O Level components.

® IGCSE is the registered trademark of Cambridge International Examinations.

1 (a) 1 mark per correctly placed tick

Statement	True	False
they are a form of spyware		✓
they are used in advertising only		✓
they are used to track the browsing of a user	✓	
they act in the same way as a virus		✓

[4]

(b)

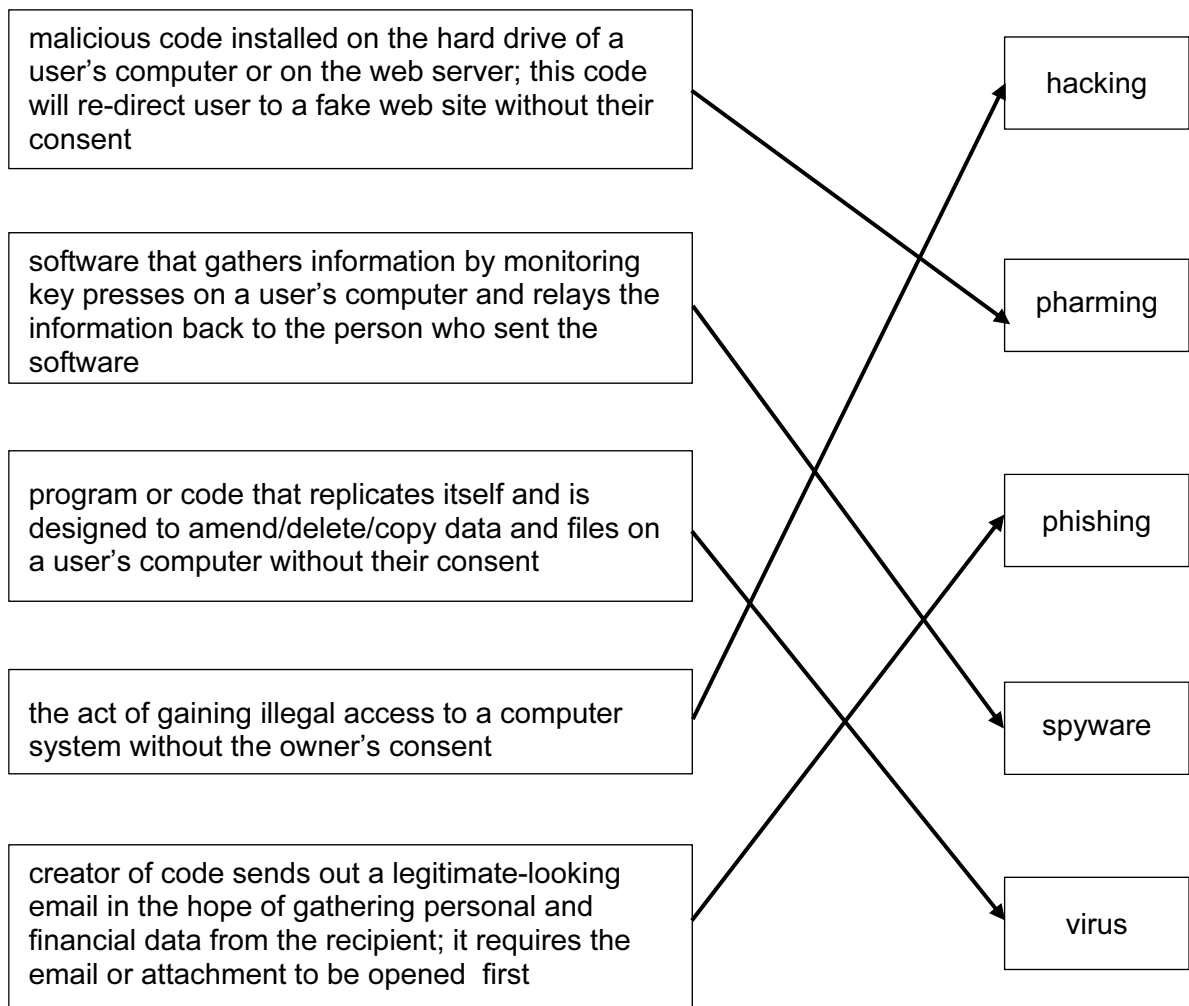

- 4/5 matches – 4 marks
- 3 matches – 3 marks
- 2 matches – 2 marks
- 1 match – 1 mark

[4]

Page 3	Mark Scheme	Syllabus	Paper
	Cambridge IGCSE – May/June 2015	0478	12

- 2 (i) Either of the three options, **resistive**, **capacitive** or **infra-red** must be chosen maximum of **two** marks from chosen technology:

**resistive**

- uses multiple layers of material ...
- ... that transmit electric currents
- when the top layer/screen is pushed/touched into the lower/bottom layer ...
- ... the electric current changes and location of “touch” is found

**capacitive**

- current sent/flows out from all 4 corners of the screen
- when finger/stylus touches screen, the current changes
- the location of “touch” is calculated

**infra-red**

- an “invisible” grid on the screen (pattern of infra-red LED beams)
- sensors detect where the screen has been touched through a break in an infrared beam(s)
- the position where the screen touched is calculated

[2]

- (ii) 1 mark for **benefit**, 1 mark for **drawback**

**Resistive**

**benefits:**

- inexpensive/cheap to manufacture
- can use stylus/finger/gloved finger/pen

**drawbacks:**

- poor visibility in sunlight
- vulnerable to scratching
- wears through time
- does not allow multi-touch facility

**capacitive**

**benefits:**

- good visibility in sunlight
- (very) durable surface
- allows multi-touch facility

**drawbacks:**

- screen (glass) will shatter/break/crack (on impact)
- cannot use when wearing (standard) gloves

**infra-red**

**benefits:**

- good durability
- allows multi-touch facility
- can use stylus/finger/gloved finger/pen

**drawbacks:**

- expensive to manufacture
- screen (glass) will shatter/break/crack (on impact)
- sensitive to dust/dirt

[2]

3

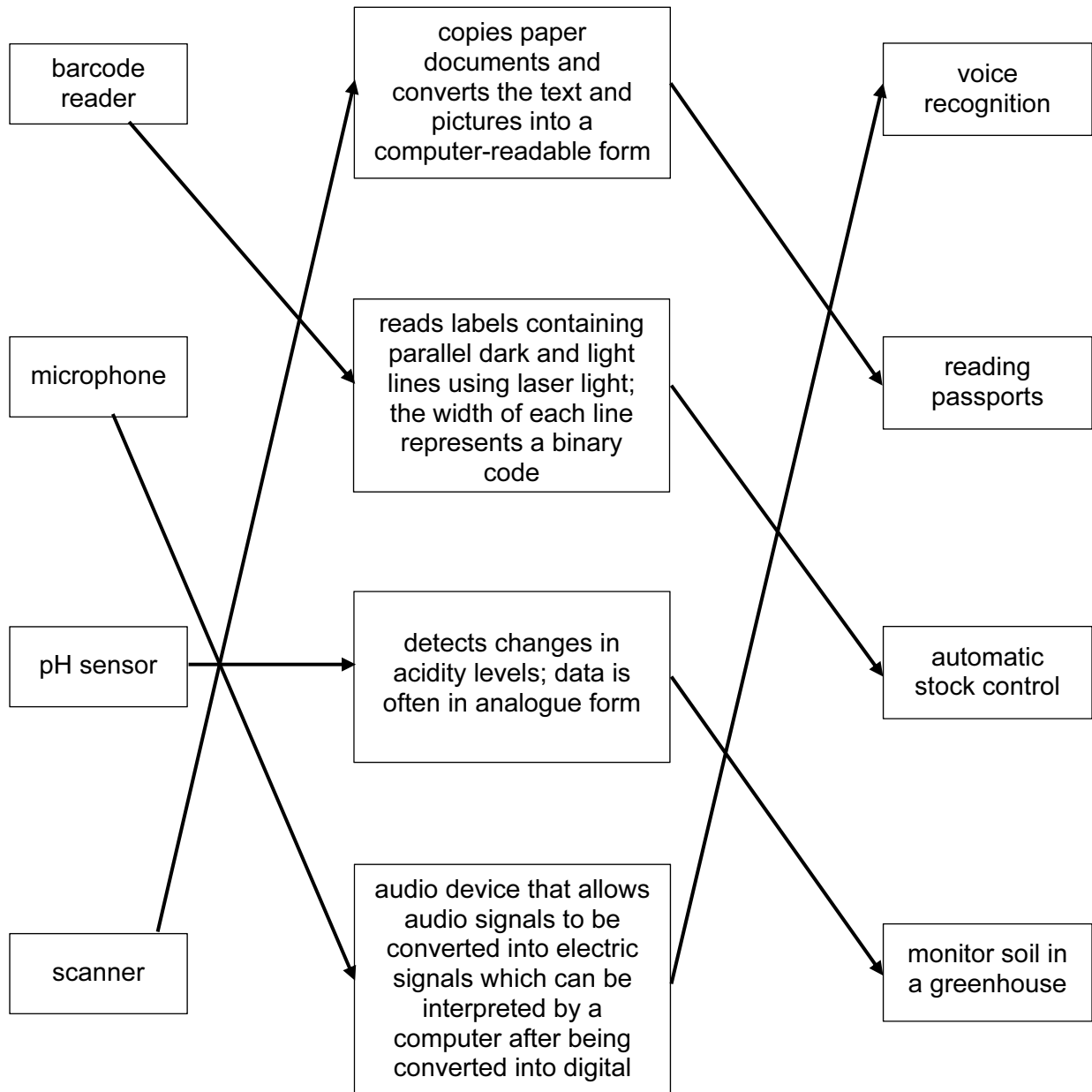

Input Device to Description  
 3/4 matches – 3 marks  
 2 matches – 2 marks  
 1 match – 1 mark

Description to Application  
 3/4 matches – 3 marks  
 2 matches – 2 marks  
 1 match – 1 mark

[6]

<b>Page 5</b>	<b>Mark Scheme</b>	<b>Syllabus</b>	<b>Paper</b>
	<b>Cambridge IGCSE – May/June 2015</b>	<b>0478</b>	<b>12</b>

4 (a) Any **one** from:

- secure sockets layer
- encrypts data being transmitted
- use of https
- use public and private keys

[1]

(b) 1 mark for each number in the correct order, next to the correct stage.

<b>Stage</b>	<b>Sequence number</b>
the encrypted data is then shared securely between the web browser and the web server	<b>6</b>
<i>the web browser attempts to connect to a web site which is secured by SSL</i>	<b>(1)</b>
the web server sends the web browser a copy of its SSL certificate	<b>3</b>
the web browser requests the web server to identify itself	<b>2</b>
the web server will then send back some form of acknowledgement to allow the SSL encrypted session to begin	<b>5</b>
the web browser checks whether the SSL certificate is trustworthy; if it is then the web browser sends a message back to the web server	<b>4</b>

[5]

5 (a) 1 mark per correctly placed tick

Received byte	Byte transmitted correctly	Byte transmitted incorrectly
1 1 0 0 1 0 0 0		✓
0 1 1 1 1 1 0 0		✓
0 1 1 0 1 0 0 1	✓	

[3]

(b) (i) byte number: 7

column number: 6

[2]

(ii) Any **two** from:

- letter “A”(byte 7) transmitted as odd parity (three 1s)
- column 6 has odd parity (seven 1s)
- intersection of byte 7 and column 6 indicates incorrect bit value

[2]

(c) 190

[1]

(d) Any **one** from:

- 2 bits interchanged (e.g. 1 → 0 and 0 → 1) that won't change parity value
- even number of bits/digits are transposed
- If there are multiple errors in the same byte/column, that still produce the same parity bit, the error will not be detected

[1]

6 (a) 1 mark per correct logic gate, correctly connected

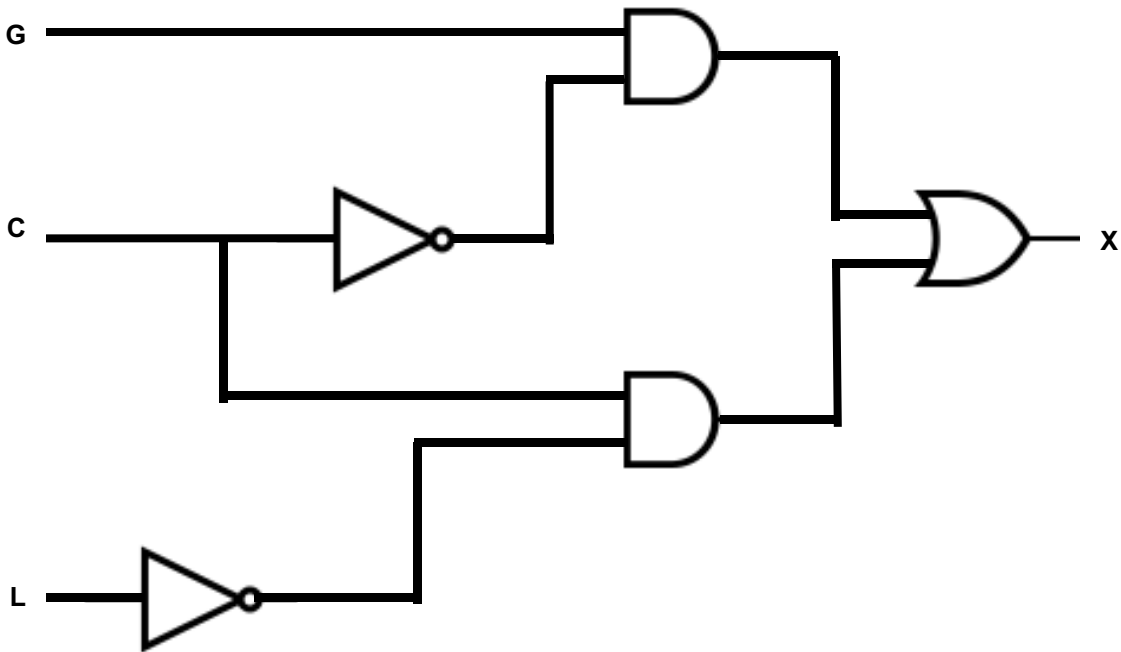

[5]

(b)

G	C	L	Workspace	X
0	0	0		0
0	0	1		0
0	1	0		1
0	1	1		0
1	0	0		1
1	0	1		1
1	1	0		1
1	1	1		0

] 1 mark

] 1 mark

] 1 mark

] 1 mark

[4]

(c) 1 mark for correctly completed truth table

<i>A</i>	<i>B</i>	<i>C</i>
0	0	<b>0</b>
0	1	<b>1</b>
1	0	<b>1</b>
1	1	<b>0</b>

[1]

7 (a) Maximum 5 marks **in total** for question part

Description of how street light is controlled: **(max 4 marks)**

- sensor sends signal/data to the microprocessor
- signal/data converted to digital/using ADC
- microprocessor compares value to a stored value
- if input value < stored value ...
- ... signal sent from microprocessor to actuator
- ... and light is switched on/off
- whole process continues in an infinite loop

Avoiding frequent on/off switches: **(max 2 marks)**

- microprocessor continues to keep light on/off for a pre-determined period
- after pre-determined period, sensor output is again sampled

[5]



<b>Page 9</b>	<b>Mark Scheme</b>	<b>Syllabus</b>	<b>Paper</b>
	<b>Cambridge IGCSE – May/June 2015</b>	<b>0478</b>	<b>12</b>

- (b) 1 mark for correct sensor, 1 mark for its matching application  
(all THREE applications must be different)

<b>sensor</b>	<b>application</b>
infra-red/motion	automatic doors burglar alarm systems
temperature	chemical process central heating/air con system greenhouse environment oven
sound/acoustic	burglar alarm systems leak detection system disco lighting
moisture/humidity	clothes drier environmental control (greenhouse, air con)
pressure	burglar alarm system traffic light control chemical process
carbon dioxide/ oxygen/gas	pollution monitoring in a river greenhouse environment (growth control) confined area (e.g. space craft) Fish tank/Aquarium
magnetic field	mobile phone anti-lock braking CD players

[6]

- 8 1 mark per correct word

Freeware

Shareware

Free software

(Computer) Ethics

Plagiarism

[5]

9 (a) 1 mark per correctly placed tick

statement	interpreter	compiler
creates an executable file that runs directly on the computer		✓
more likely to crash the computer since the machine code produced runs directly on the processor		✓
easier to debug since each line of code is analysed and checked before being executed	✓	
slow speed of execution of program loops	✓	
it is more difficult to modify the code since the executable code is now in machine code format		✓

[5]

(b) Any **one** from:

- code is required to be converted into machine code/binary
- code needs to be produced that can be understood by the computer

[1]

(c) Any **one** from:

- close to English/native/human language
- easier/faster to correct errors/read/write
- works on many different machines/operating systems (portable)

[1]

(d) Any **one** from:

- work directly on registers/CPU
- more control over what happens in computer
- can use machine specific functions

[1]

(e) 1 mark per correct letter, maximum 2 marks

Assembly code: **B**  
 High-level language code: **C**  
 Machine code: **A**

[2]

**10 (a)** 1 mark for two correct lines, 2 marks for four correct lines

<b>L (108):</b>	<b>0</b>	<b>1</b>	<b>1</b>	<b>0</b>	<b>1</b>	<b>1</b>	<b>0</b>	<b>0</b>
<b>I (105):</b>	<b>0</b>	<b>1</b>	<b>1</b>	<b>0</b>	<b>1</b>	<b>0</b>	<b>0</b>	<b>1</b>
<b>G (103):</b>	<b>0</b>	<b>1</b>	<b>1</b>	<b>0</b>	<b>0</b>	<b>1</b>	<b>1</b>	<b>1</b>
<b>N (110):</b>	<b>0</b>	<b>1</b>	<b>1</b>	<b>0</b>	<b>1</b>	<b>1</b>	<b>1</b>	<b>0</b>

[2]

**(b)** 1 mark for each correct binary value  
1 mark for each correct hexadecimal value

									hexidecimal
<b>L:</b>	<b>1</b>	<b>1</b>	<b>0</b>	<b>1</b>	<b>1</b>	<b>0</b>	<b>0</b>	<b>0</b>	<b>D8</b>
<b>G:</b>	<b>1</b>	<b>1</b>	<b>0</b>	<b>0</b>	<b>1</b>	<b>1</b>	<b>1</b>	<b>0</b>	<b>CE</b>

[4]