



Cambridge International Examinations
Cambridge International General Certificate of Secondary Education

CANDIDATE
NAME

--

CENTRE
NUMBER

--	--	--	--	--

CANDIDATE
NUMBER

--	--	--	--



DESIGN AND TECHNOLOGY

0445/42

Paper 4 Systems and Control

October/November 2016

1 hour

Candidates answer on the Question Paper.

No Additional Materials are required.

READ THESE INSTRUCTIONS FIRST

Write your Centre number, candidate number and name on all the work you hand in.

Write in dark blue or black pen.

You may use an HB pencil for any diagrams or graphs.

Do not use staples, paper clips, glue or correction fluid.

DO NOT WRITE IN ANY BARCODES.

Section A

Answer **all** questions in this section.

Section B

Answer **one** question in this section.

You may use a calculator.

At the end of the examination, fasten all your work securely together.

The number of marks is given in brackets [] at the end of each question or part question.

The total of the marks for this paper is 50.

This document consists of **19** printed pages and **1** blank page.

Section A

Answer **all** questions in this section.

- 1 Fig. 1 shows a wooden beam supported at **A** and **B** with a test instrument in position.

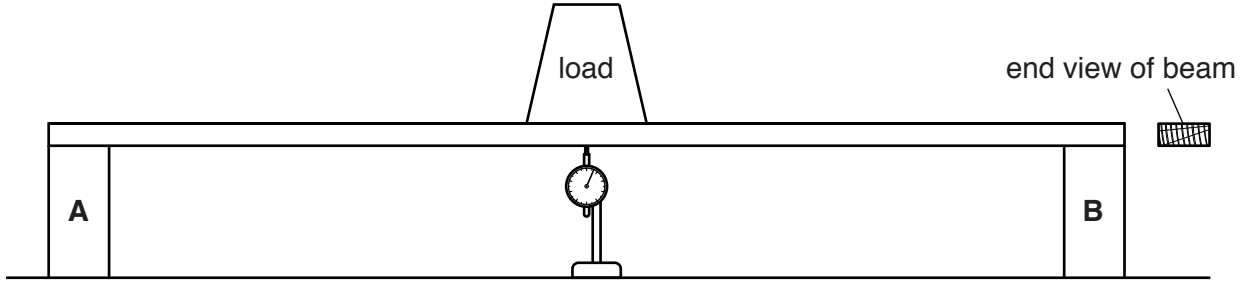

Fig. 1

- (a) Name the test instrument.

.....[1]

- (b) Give the term used to describe the movement of the beam that will be measured in the test.

.....[1]

- (c) Describe how the movement of the beam could be reduced when using the same beam with the same load.

.....
.....[2]

2 Fig. 2 shows a barrow used to move heavy loads.

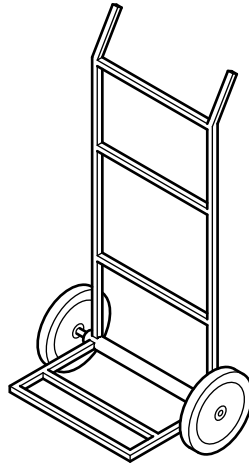

Fig. 2

(a) Name the order of lever that is used in the barrow.

.....[1]

(b) Draw on Fig. 2 to show **two** methods of reinforcing the structure to prevent distortion when heavy loads are carried. [2]

3 (a) Choose an electrical conductor from the list below.

- rubber acrylic silver silicon ABS**

.....[1]

(b) Give **one** reason why wood does not make a good electrical insulator.

.....[1]

4 Fig. 3 shows a transistor and the diagram used to identify the pins.

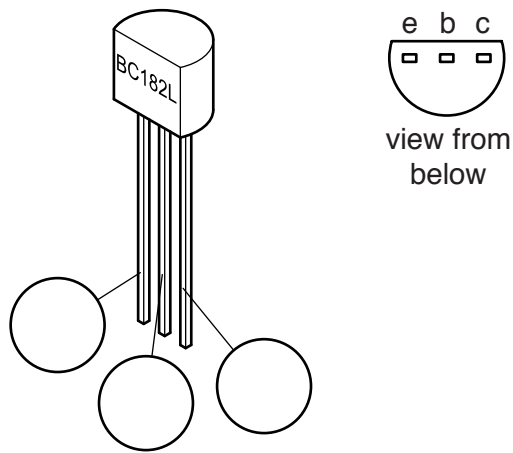

Fig. 3

(a) (i) Use the information given in Fig. 3 to label all of the pins on the transistor. [2]

(ii) Give the full name of the pin marked 'e'.

.....[1]

(b) Fig. 4 shows two possible track layouts for connecting the transistor to a printed circuit board.

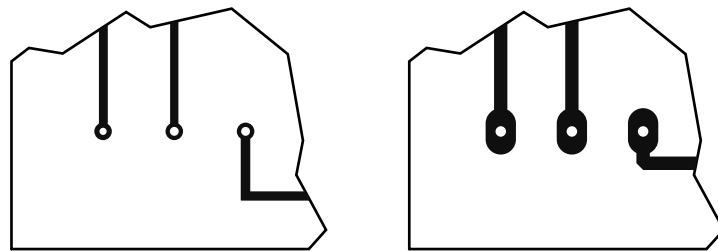

Fig. 4

Give **two** advantages of using the larger pad and track size.

1

2[2]

5 Name the electronic symbols shown in Fig. 5.



.....

.....

.....

Fig. 5

[3]

6 Name **three** power sources used to drive mechanical systems.

- 1
- 2
- 3[3]

7 Fig. 6 shows a winch on a dockside crane.

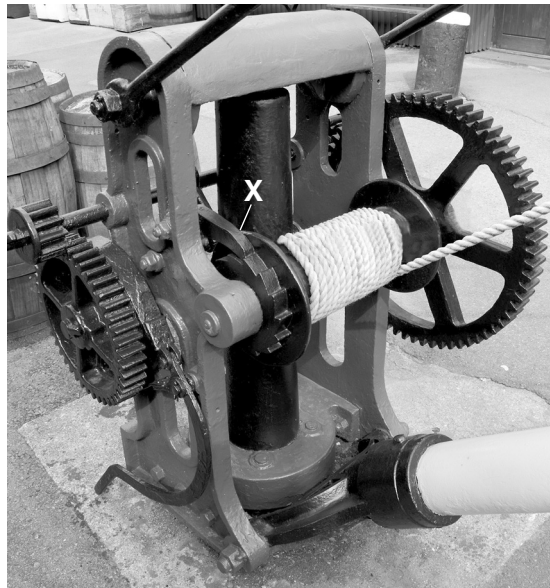

Fig. 6

(a) Name the mechanism used at X.

.....[2]

(b) Give **one** reason for using this mechanism.

.....[1]

8 Give the conversion of motion that takes place when a screw thread is used.

..... to[2]

Section B

Answer **one** question in this section.

- 9 (a) Complete the table below by drawing lines linking each material with the correct property. One has been done for you.

Material	Property
steel cable	high compressive strength
carbon fibre reinforced polymer	high tensile strength
wood	can be melted and reformed
stone	high strength to weight ratio
thermoplastic	renewable resource

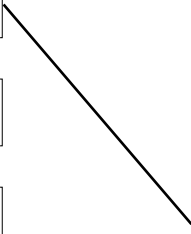

[4]

(b) Fig. 7 shows a tower crane made from steel tubes.

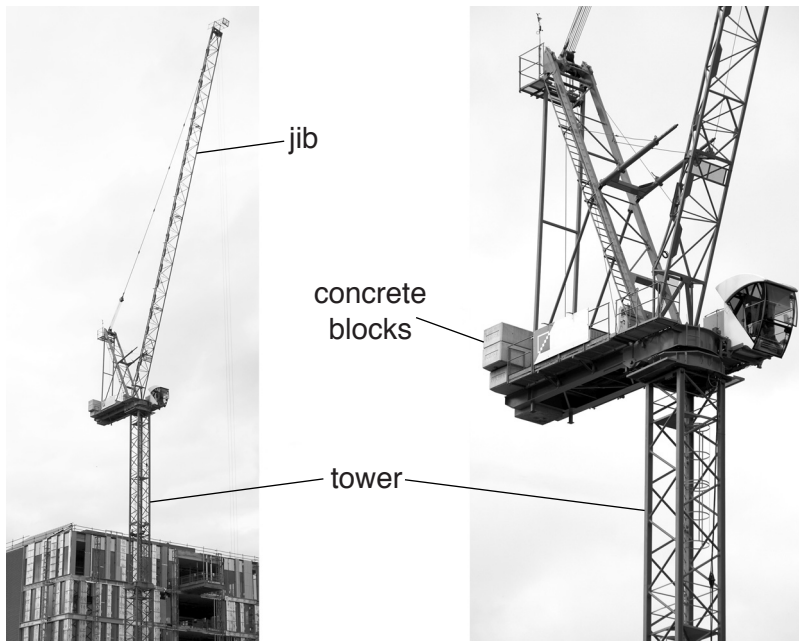

Fig. 7

(i) Explain the purpose of the concrete blocks.

.....

[2]

(ii) State what gives the tower rigidity.

.....[1]

(iii) State what is meant by the term 'torsion'.

.....
[1]

(iv) Give **two** causes of torsional force acting on the tower crane when it is in use.

1
 2[2]

- (c) Fig. 8 shows two pieces of softwood that must be joined end to end to extend the length of a beam.

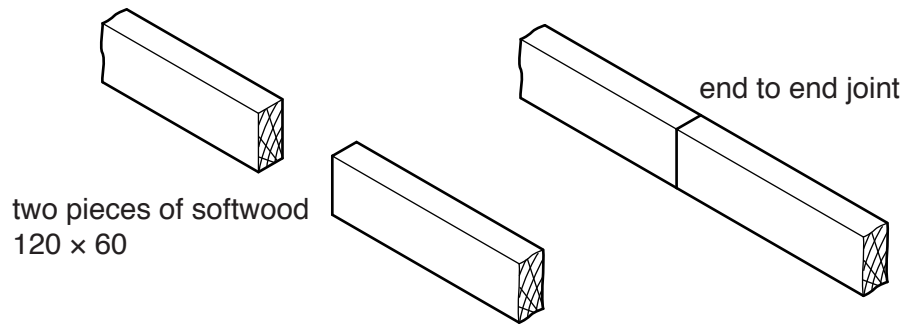

Fig. 8

- (i) Use sketches and notes to show **one** method of joining the two pieces of softwood end to end.
Label any extra components and materials used.

[4]

- (ii) An alternative way of extending beam length is to laminate several pieces of softwood as shown in Fig. 9.

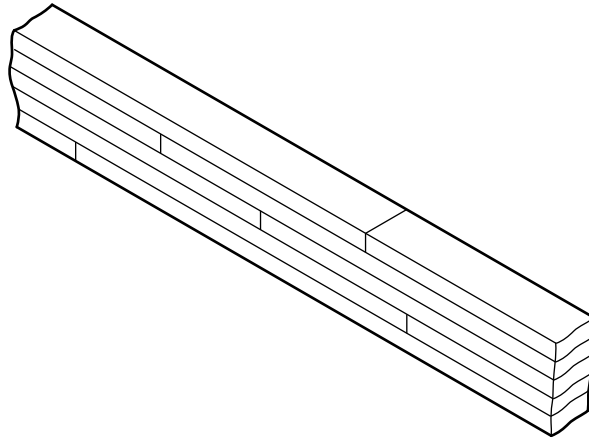

Fig. 9

Give **one** other advantage of laminating a beam rather than joining pieces end to end.

.....
.....[1]

- (iii) Two methods of joining timber are shown in Fig. 10.

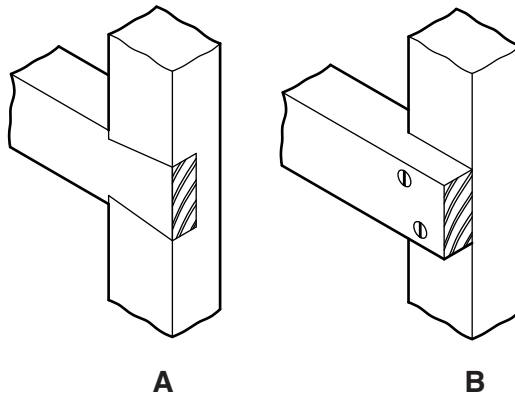

Fig. 10

Give **two** benefits of method **A**.

1
2[2]

- (iv) Give **two** benefits of method **B**.

1
2[2]

(d) Fig. 11 shows a cantilever beam that is fixed into a wall.

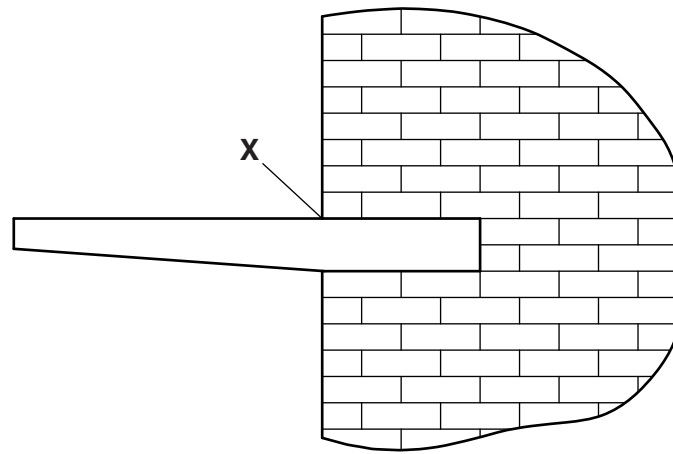

Fig. 11

(i) State the vertical force that could cause failure of the beam at point X.

.....[1]

(ii) Describe how a designer using a beam of this type will consider a factor of safety.

.....

[2]

(e) Fig. 12 shows a beam loaded on one side.

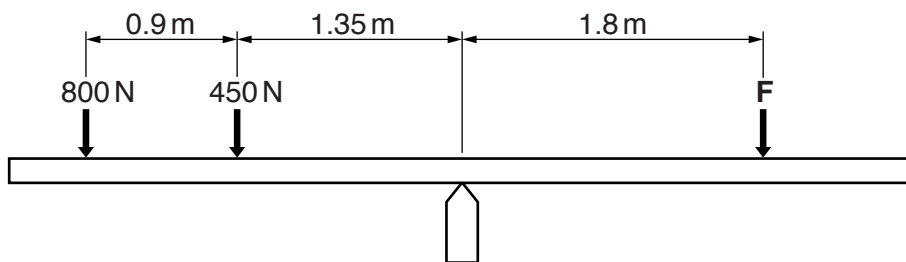

Fig. 12

Calculate the force **F** needed to balance the beam.

.....

[3]

10 (a) Fig. 13 shows the outline of a cam.

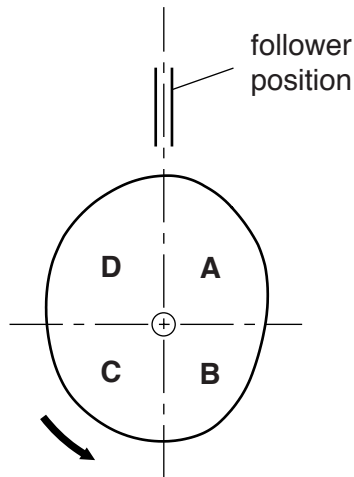

Fig. 13

(i) Draw a roller follower on the cam. [2]

(ii) Fig. 13 shows the four areas of movement, **A**, **B**, **C** and **D**, produced by the cam. State which area contains 'dwell'.

.....[1]

(iii) Describe the movement of the follower for one revolution of the cam, starting in the position shown.

.....

[3]

(b) Fig. 14 shows a small hydraulic car jack and a schematic view of how it operates.

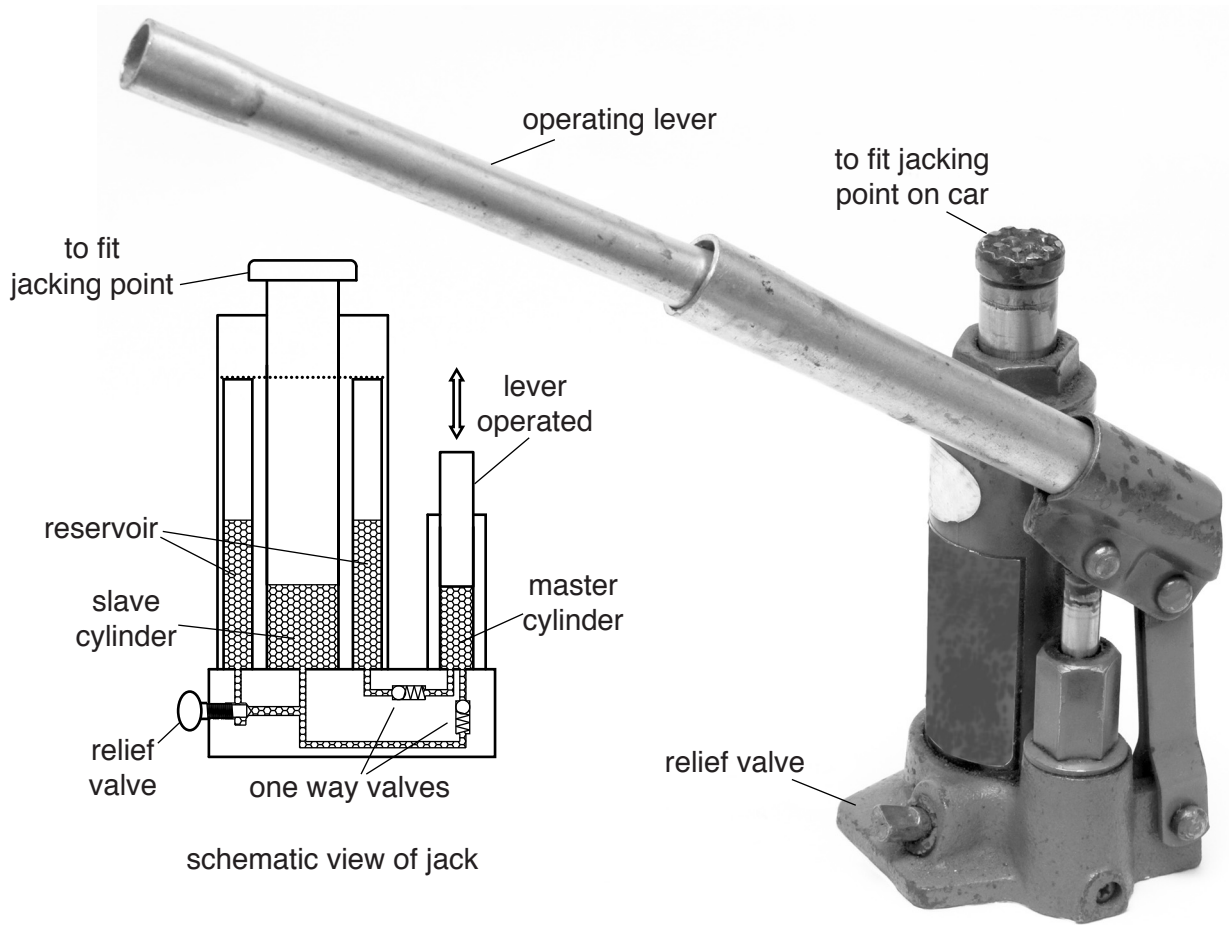

Fig. 14

(i) Mark the load, effort and fulcrum on the operating lever. [3]

(ii) Describe what will happen when the relief valve is closed and the operating lever is used.

.....

 [2]

(iii) Describe what will happen when the relief valve is opened with a load on the jack.

.....

 [2]

(iv) Give **two** reasons why a pneumatic system would not be suitable for use in a car jack.

- 1
- 2 [2]

(c) Fig. 15 shows a prototype for a device to operate a spray can for use by people with limited strength and movement.



Fig. 15

(i) Explain why the device will make operation of the spray can easier.

-
-
- [2]

(ii) Nylon gears are used in the prototype.
Give **two** benefits of nylon as a material for gears.

- 1
-
- 2
- [2]

- (d) Fig. 16 shows two steel machine parts that have to move against each other in the direction of the arrows.

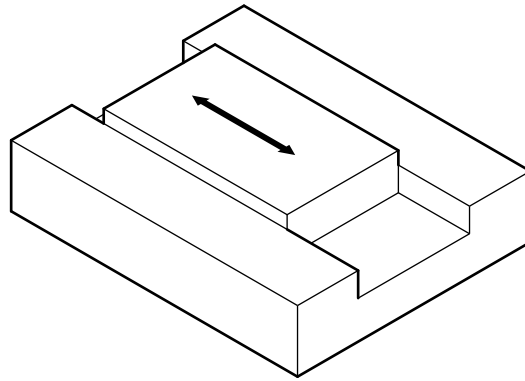

Fig. 16

- (i) State the name of the force that will oppose the movement.

.....[1]

- (ii) Use sketches and notes to show how the design can be modified to reduce the effect of the force and allow easier movement of the two steel parts.

[3]

- (e) Fig. 17 shows a threaded rod with dimensions.

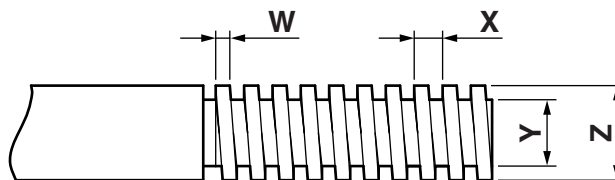

Fig. 17

Give the letter of the dimension for the following features:

Thread pitch[1]

Thread diameter[1]

11 (a) Fig. 18 shows a circuit diagram for a transistor touch switch.

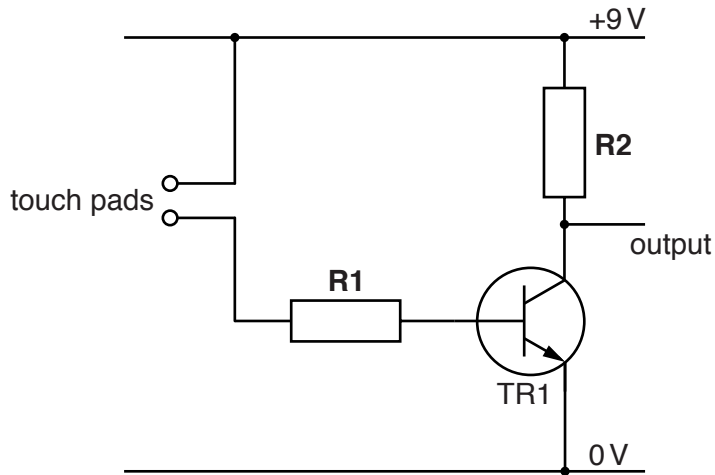
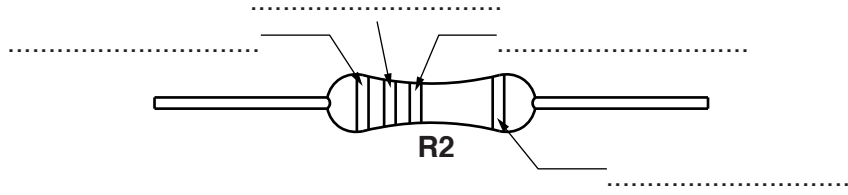

Fig. 18

- (i) State the purpose of resistor **R1**.
.....[1]
- (ii) State the purpose of resistor **R2**.
.....[1]
- (iii) Give **two** advantages of a transistor switch over a mechanical switch.
1
2[2]
- (iv) Give **one** disadvantage of a transistor switch compared to a mechanical switch.
.....[1]

- (v) Fig. 19 shows the colour bands on resistor **R2**. The resistor value is $15\text{ k}\Omega$ 5% tolerance. Use the table to complete the colours on the bands of resistor **R2**.



First Band	Second Band	Multiplier Band	Tolerance
			SILVER $\pm 10\%$
			GOLD $\pm 5\%$
BLACK – 0	BLACK – 0	BLACK – 0	
BROWN – 1	BROWN – 1	BROWN – 1	BROWN $\pm 1\%$
RED – 2	RED – 2	RED – 2	RED $\pm 2\%$
ORANGE – 3	ORANGE – 3	ORANGE – 3	
YELLOW – 4	YELLOW – 4	YELLOW – 4	
GREEN – 5	GREEN – 5	GREEN – 5	
BLUE – 6	BLUE – 6	BLUE – 6	
VIOLET – 7	VIOLET – 7	VIOLET – 7	
GREY – 8	GREY – 8	GREY – 8	
WHITE – 9	WHITE – 9	WHITE – 9	

Fig. 19

[4]

- (b) (i) Fig. 20 shows an arrangement of logic gates and a truth table. Complete the truth table.

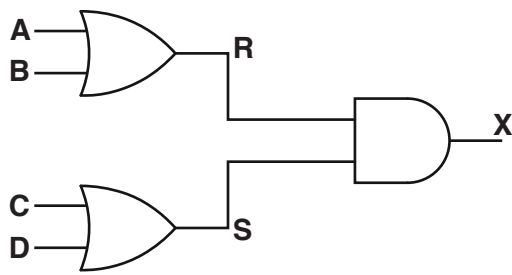

A	B	R	C	D	S	X
0	0		0	0		
0	1		0	1		
1	0		1	0		
1	1		1	1		

Fig. 20

[3]

- (ii) A dual in line CMOS logic IC is shown in Fig. 21.

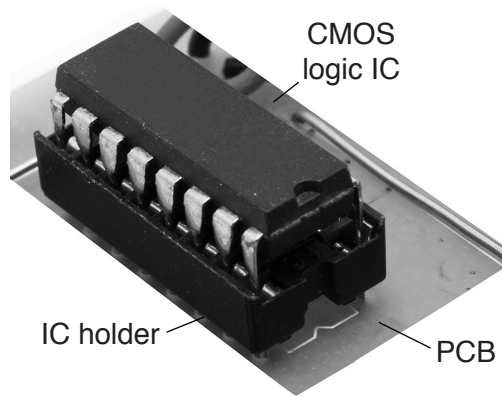

Fig. 21

Give the meaning of 'dual in line'.

.....
 [2]

- (iii) Give **one** benefit of using an IC holder.

..... [1]

(c) Fig. 22 shows the circuit for controlling a car engine cooling fan.
 A data table for the thermistor showing resistance at a range of temperatures is shown.

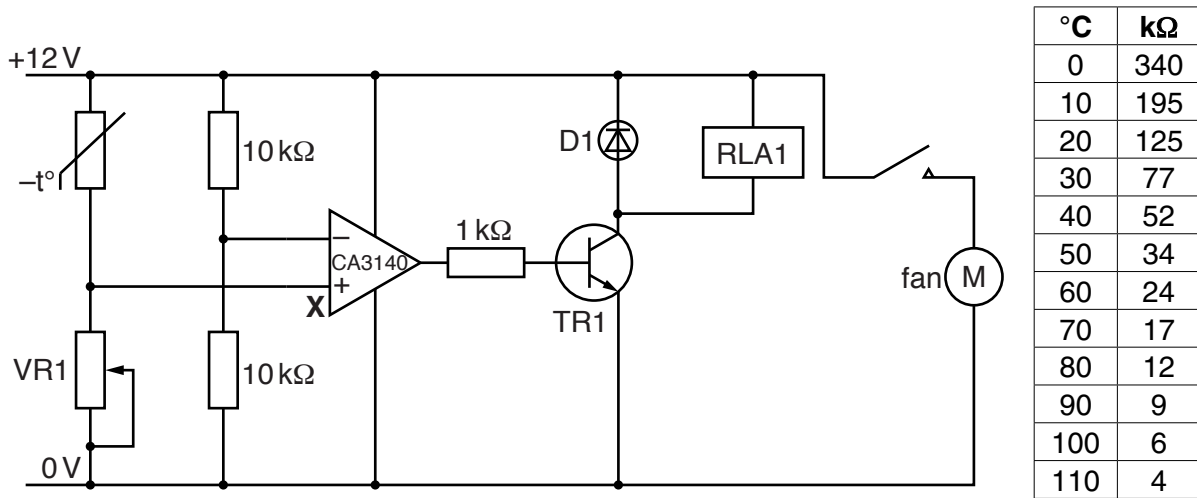

Fig. 22

(i) Relay RLA1 switches the fan on.
 State the contact arrangement for the relay from the list below.

- SPST DPST DPDT SPDT

.....[1]

(ii) The cooling fan should switch on when the engine temperature reaches 110°C.
 State the resistance of the thermistor at 110°C.

.....[1]

(iii) To change the output of the CA3140 operational amplifier, 6.1V is required at point X.
 Calculate the value that VR1 should be set at to produce 6.1V at point X.

Use the formula $V_{out} = \frac{R2}{R1+R2} \times V_{in}$

.....

[3]

(iv) Explain how the CA3140 operational amplifier can provide a positive voltage at the output.

.....

[2]

- (v) Fig. 23 shows the pin diagram and part of a printed circuit board (PCB) layout for the operational amplifier.
 Add the power connections from the CA3140 IC to the PCB layout.

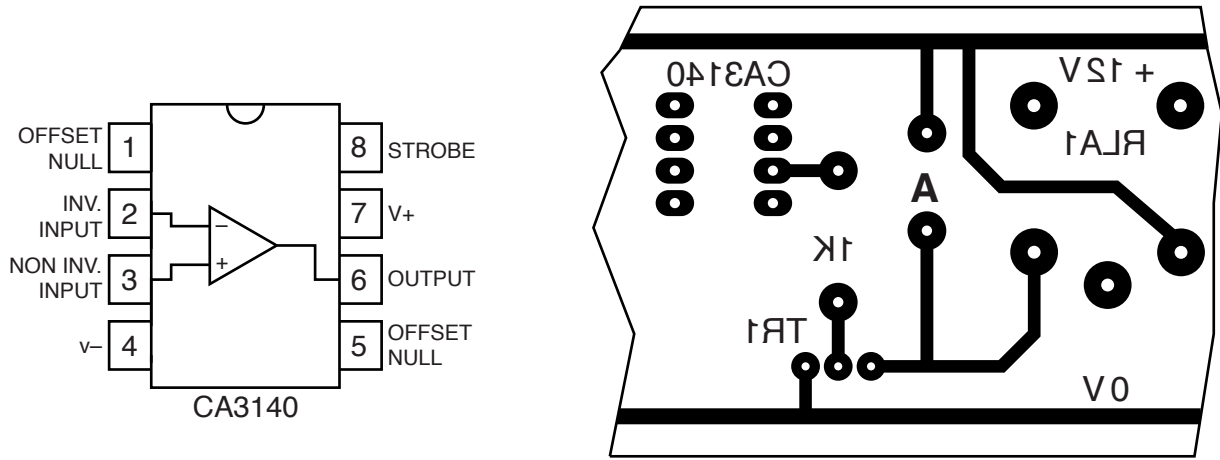

Fig. 23

[2]

- (vi) Use information from Fig. 22 to give the name of the component that fits in space **A** on the PCB in Fig. 23.

.....[1]

BLANK PAGE

Permission to reproduce items where third-party owned material protected by copyright is included has been sought and cleared where possible. Every reasonable effort has been made by the publisher (UCLES) to trace copyright holders, but if any items requiring clearance have unwittingly been included, the publisher will be pleased to make amends at the earliest possible opportunity.

To avoid the issue of disclosure of answer-related information to candidates, all copyright acknowledgements are reproduced online in the Cambridge International Examinations Copyright Acknowledgements Booklet. This is produced for each series of examinations and is freely available to download at www.cie.org.uk after the live examination series.

Cambridge International Examinations is part of the Cambridge Assessment Group. Cambridge Assessment is the brand name of University of Cambridge Local Examinations Syndicate (UCLES), which is itself a department of the University of Cambridge.