

Section A

Answer **all** questions in this section.

A1 A design for a birthday card is shown on the right.
The design is made from a sheet of A4 card, folded.



(a) Complete the scale 1:2 drawing of the design for the front and back of the birthday card below by:

- (i) completing the outline of the 296 × 210 A4 sheet of card; [2]
- (ii) drawing the centre fold line; [2]
- (iii) rendering the balloons to make them appear three-dimensional. [2]

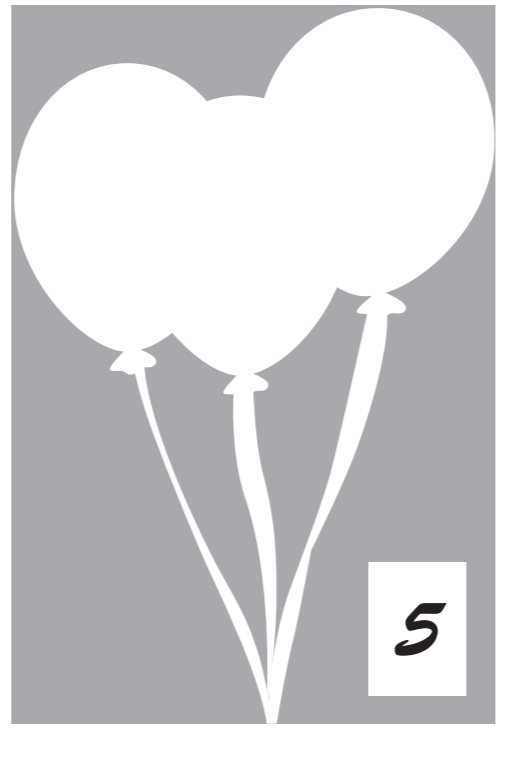

(b) Use a sketch and notes to show how to use a stencil to add the number 5 to the bottom right corner of the front of the birthday card. [3]

A2 The strip of card below is to be used to add a pop-up mechanism inside the birthday card.



(a) Complete the sketch of the inside of the birthday card below by adding the strip of card used to make the pop-up mechanism. [4]

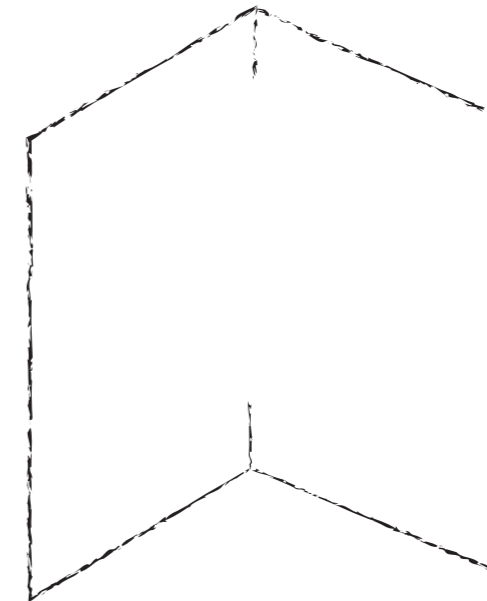

(b) State **two** methods of joining the strip of card to the birthday card.

- 1. [1]
- 2. [1]

For Examiner's use

A3 An assortment of 25 birthday cards is packaged in a box. A sketch of the development (net) of the box and the two seals that hold it together is shown below.

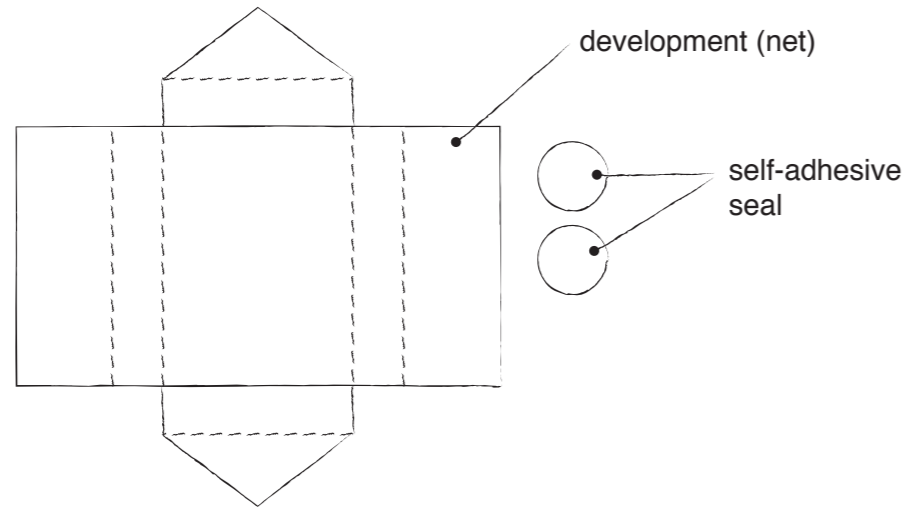

(a) Complete the orthographic views below of the assembled package for the birthday cards. [6]

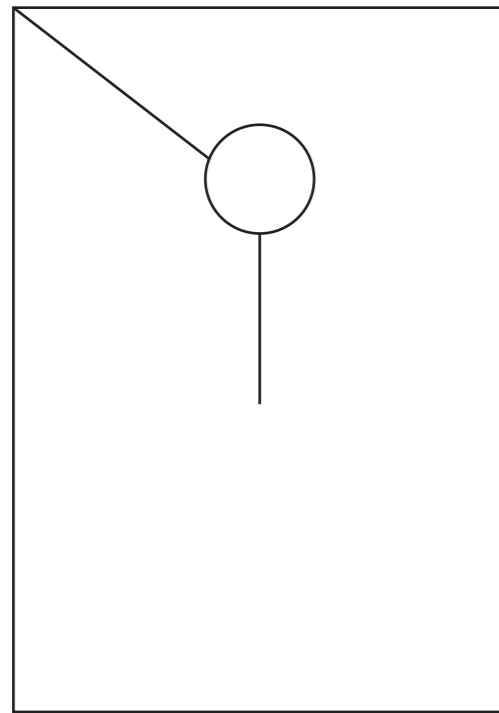

front view



end view



plan

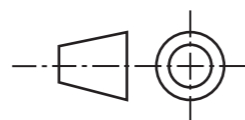

(b) The sales of three different birthday card designs in 2016 are shown below.

	balloons	horses	pirates
sales	800	400	600

On the centre lines below draw a pie chart to show the sales of the three different birthday card designs. Use labels to enhance the appearance of the drawing. [4]

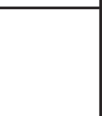
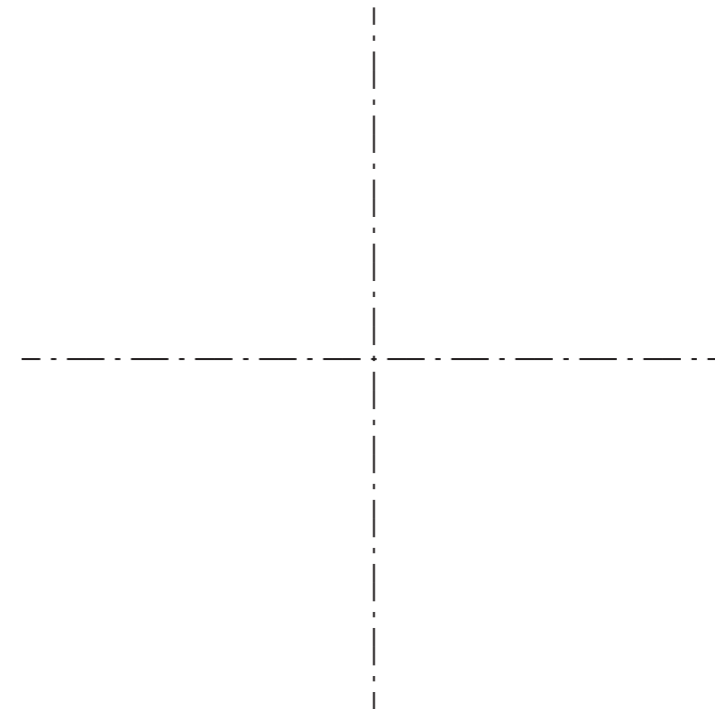

Section B
Answer **either** question **B4** or **B5**.

B4 The parts of a model of a bridge are shown in the table below.

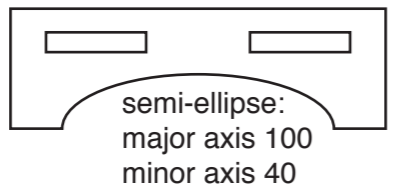
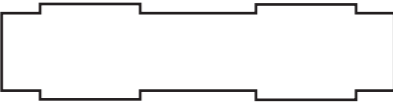
part		number
sides		2
road		1

(a) Complete the orthographic views below of the fully assembled model of the bridge. Show all hidden detail.

[16]

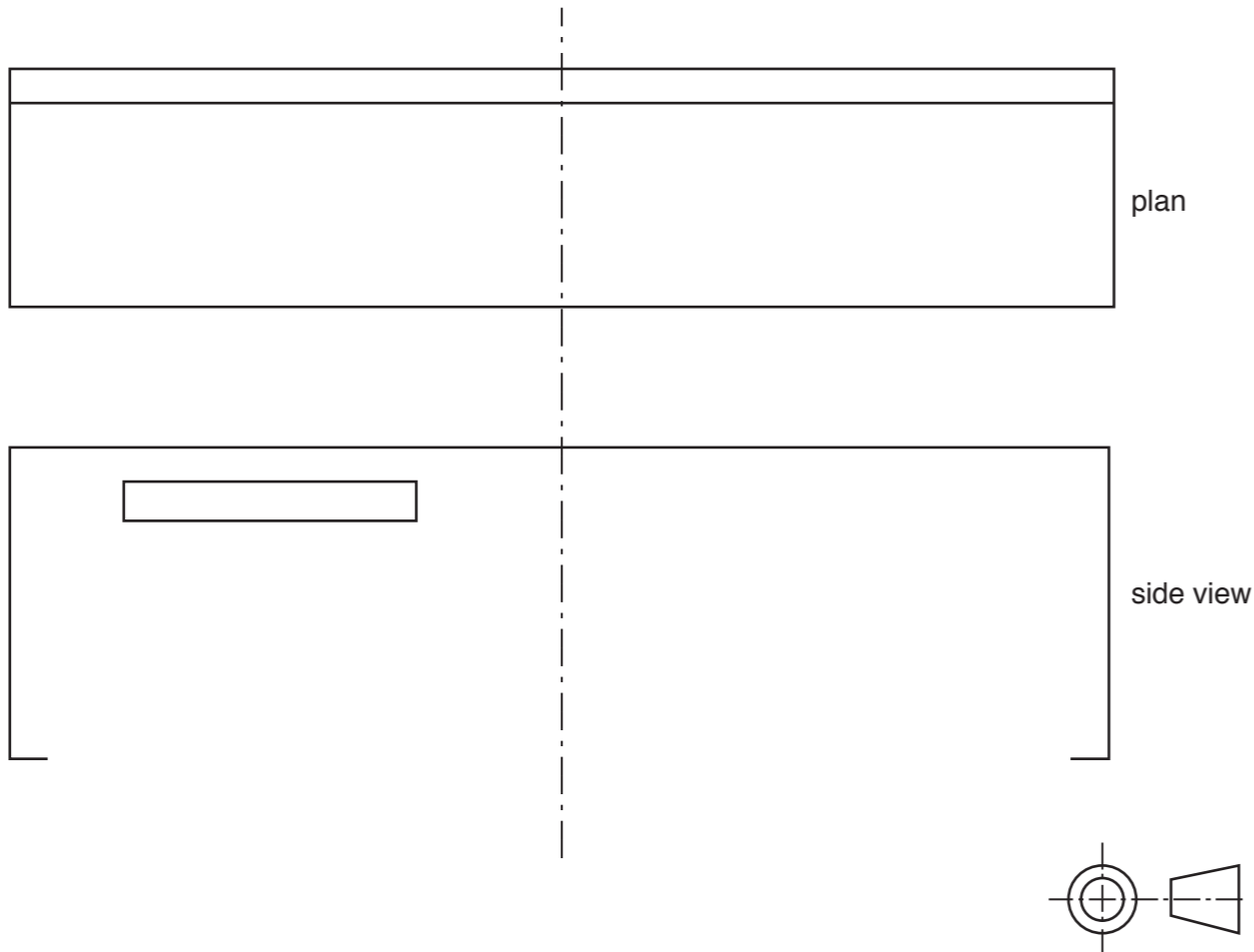

(b) The model of the bridge is made from foam board.

(i) Draw and label a sectional view of foam board.

[3]

(ii) Complete the list below to show the equipment required to cut out the parts of the model of the bridge from the sheet of foam board.

1. Cutting mat

2. [1]

3. [1]

(c) During the testing of the model of the bridge the road part becomes loose in the slots and the bridge falls apart.

Use a sketch and notes to show a method of overcoming this problem.

[4]

For Examiner's use

B5 A sketch of a design for a desk tidy is shown to the right.

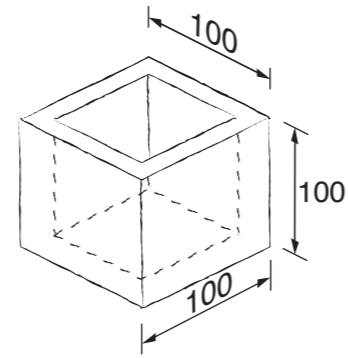

(a) Complete sketches below to show the material and construction of **two** models of the desk tidy. [8]

<p>Model 1 Material 3 mm plastic sheet</p> <p>Construction made from one piece of folded 3 mm plastic sheet</p>	
<p>Model 2 Material 10 mm wood</p> <p>Construction made from five pieces of 10 mm wood joined together</p>	

(b) Give **two** reasons why plastic sheet is a suitable material for model 1.

1.[1]

2.[1]

(c) During testing it was found to be difficult to get small items out from the bottom of model 2. To overcome this problem model 2 was cut at an angle along the line XX.

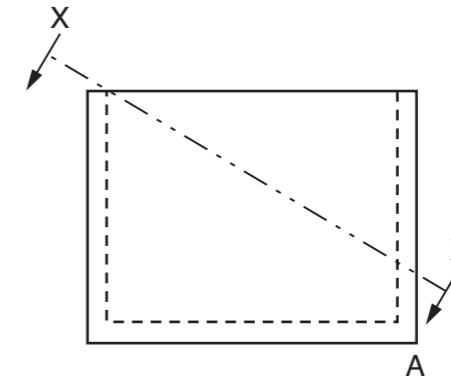

On the start lines below complete the scale 1:2 isometric view of model 2 made from 10 mm wood. [12]

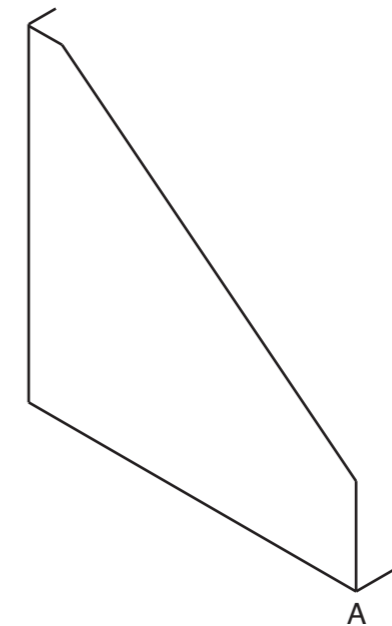

(d) Use sketches and notes to show a way of adding a child's name to model 2. [3]

