

Section A

Answer **all** questions in this section.

The drawings below show details of a swing ticket used in a clothes shop. The ticket is printed with a profile to represent the product on sale.

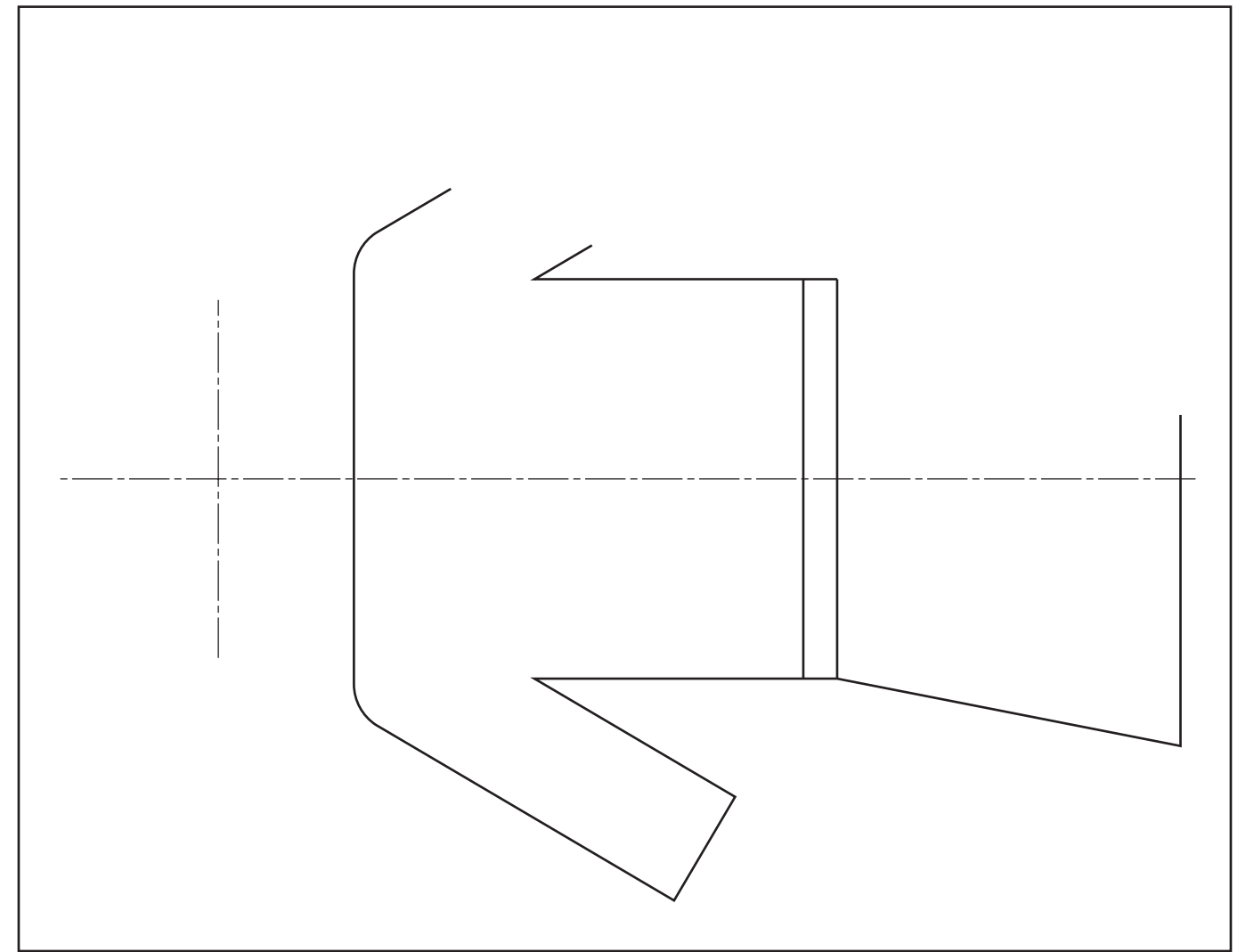
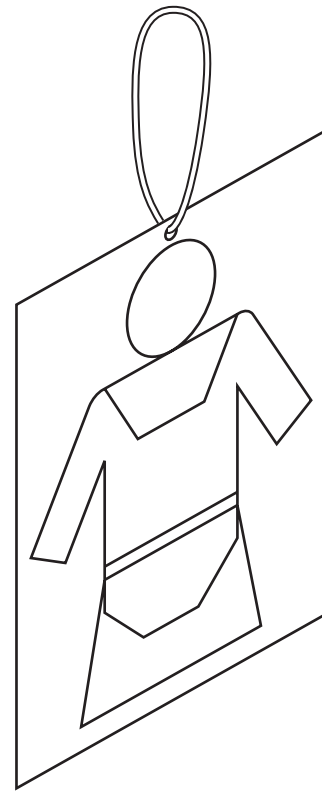
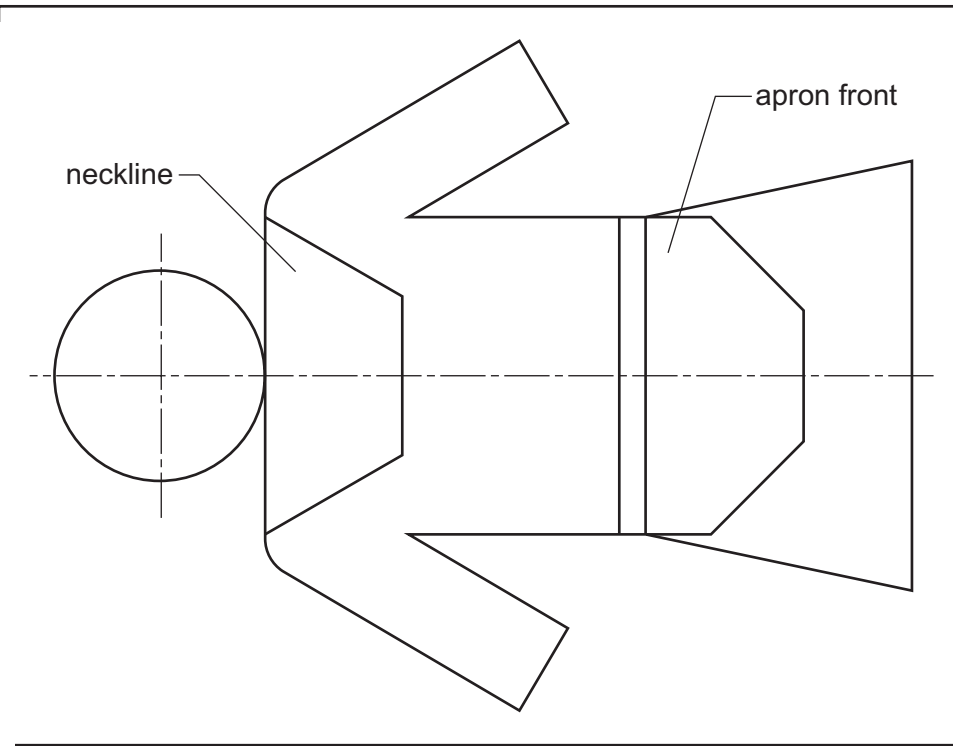

Complete the full size view of the swing ticket by drawing on the centre lines given in the space provided to the right:

- the Ø40 circle representing the head; [1]
- the half hexagon 30 side representing the neckline; [2]
- the half octagon 60 A/F representing the apron front; [3]
- the missing arm and dress outline. [3]

An incomplete signboard for the clothes shop is drawn to the right.

Complete the sign FASHION WORLD by adding:

- the remaining part of the signboard;
- the **two** missing letters. [6]

All the letters must be to the same height and style as those given.



For Examiner's use

0445/23 Oct/Nov 2011 **1 hour**

© UCLES 2011

Centre Number

Candidate's Number

Candidate's Surname

Other Names

[Turn over]

A3 Drawn below are the two components of a counter top stand used to display jewellery. The base and upright are made from expanded polystyrene.

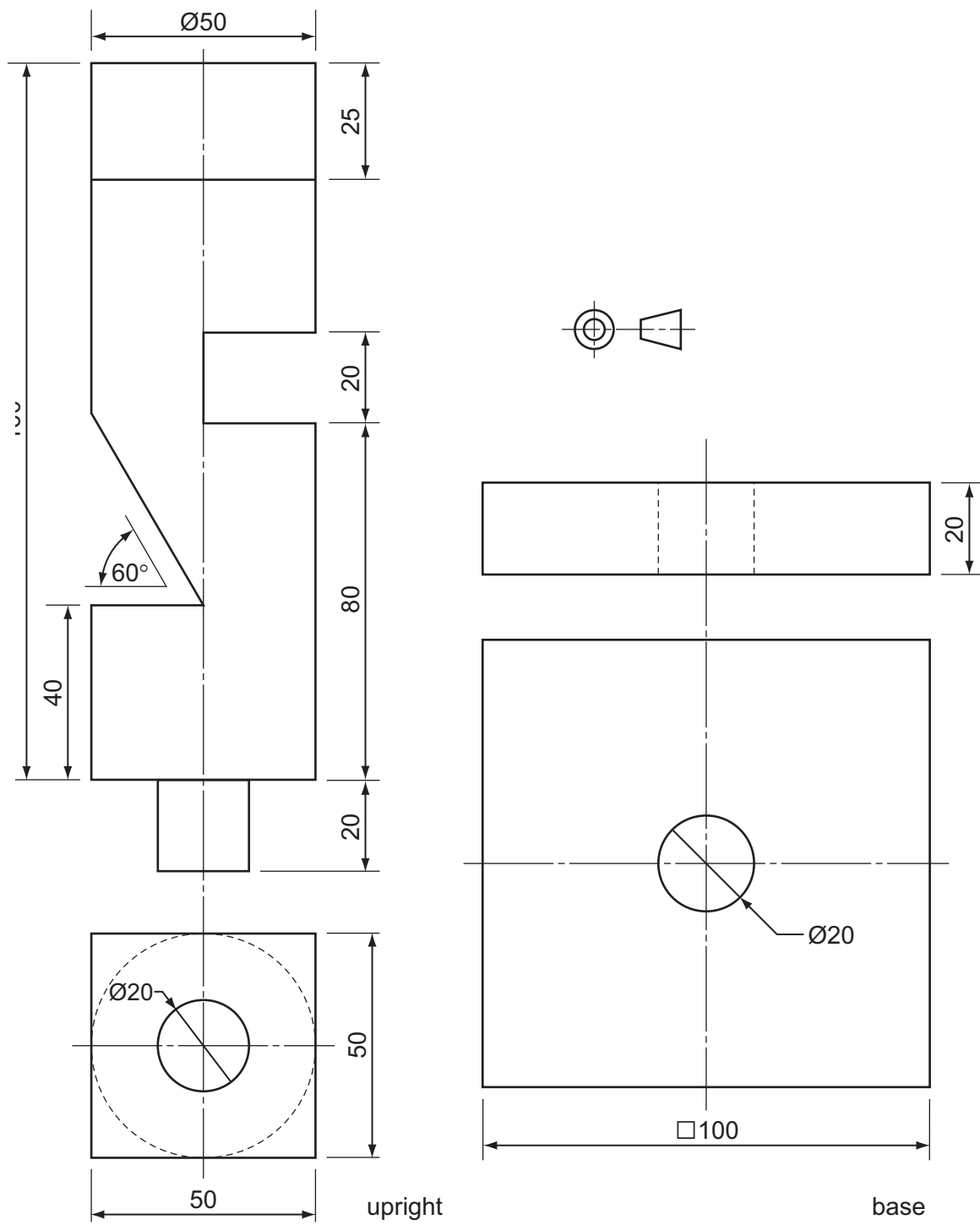

(a) In the space to the right, draw a full size isometric view of the two components when assembled. [7]

(b) Apply thick and thin line technique to the triangular slot **only**, to enhance its appearance. [3]

Section B

Answer **either** question **B4** or **B5**.

B4 The sketch below shows a bag used to package a gift.

The bag is made from a one-piece development of 100 g/m² paper.

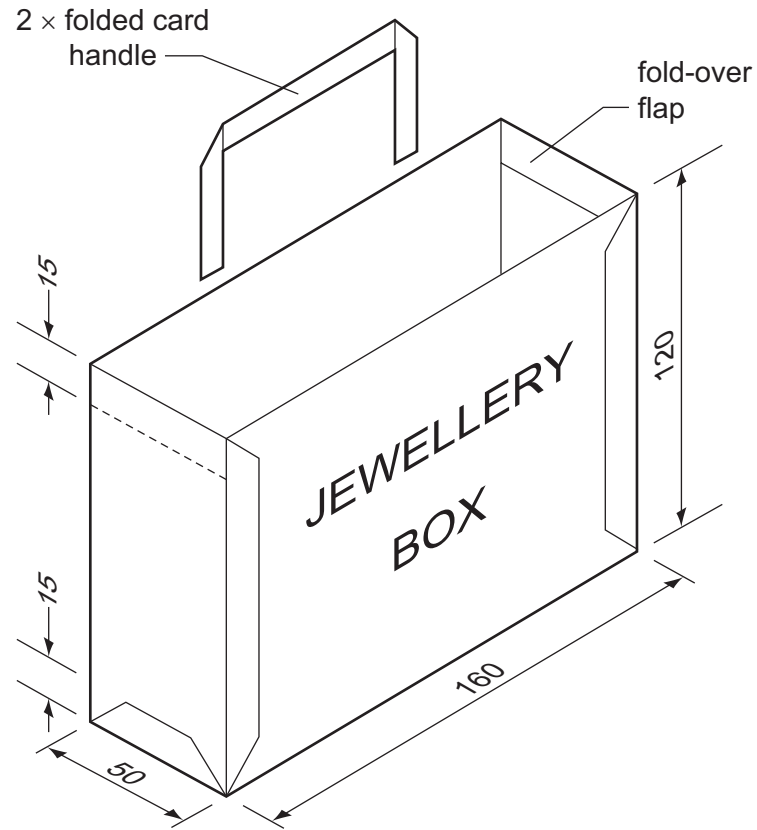

- (a) In the space provided to the right, draw to a scale of 1:2 a one-piece development (net) of the bag. The development must include all the glue tabs and fold-over flaps. [15]
- (b) Print the words JEWELLERY BOX on the correct face of the development you have drawn in (a). The words must be in the correct orientation and in proportion to the bag. [5]

- (c) In the space to the right, sketch a method of securely attaching one of the folded card handles to the top of the bag. [5]

0445/23 Oct/Nov 2011 1 hour
© UCLES 2011

Centre Number

Candidate's Number

Candidate's Surname

Other Names

[Turn over]

B5 The exploded views below show details of a wristwatch display stand. The band and the upright are made from acrylic and joined together using acrylic cement.

The upright has a double tenon shape that pushes into 3 mm wide slots in the elliptical wooden base. The band sits on the 30 long horizontal part of the upright

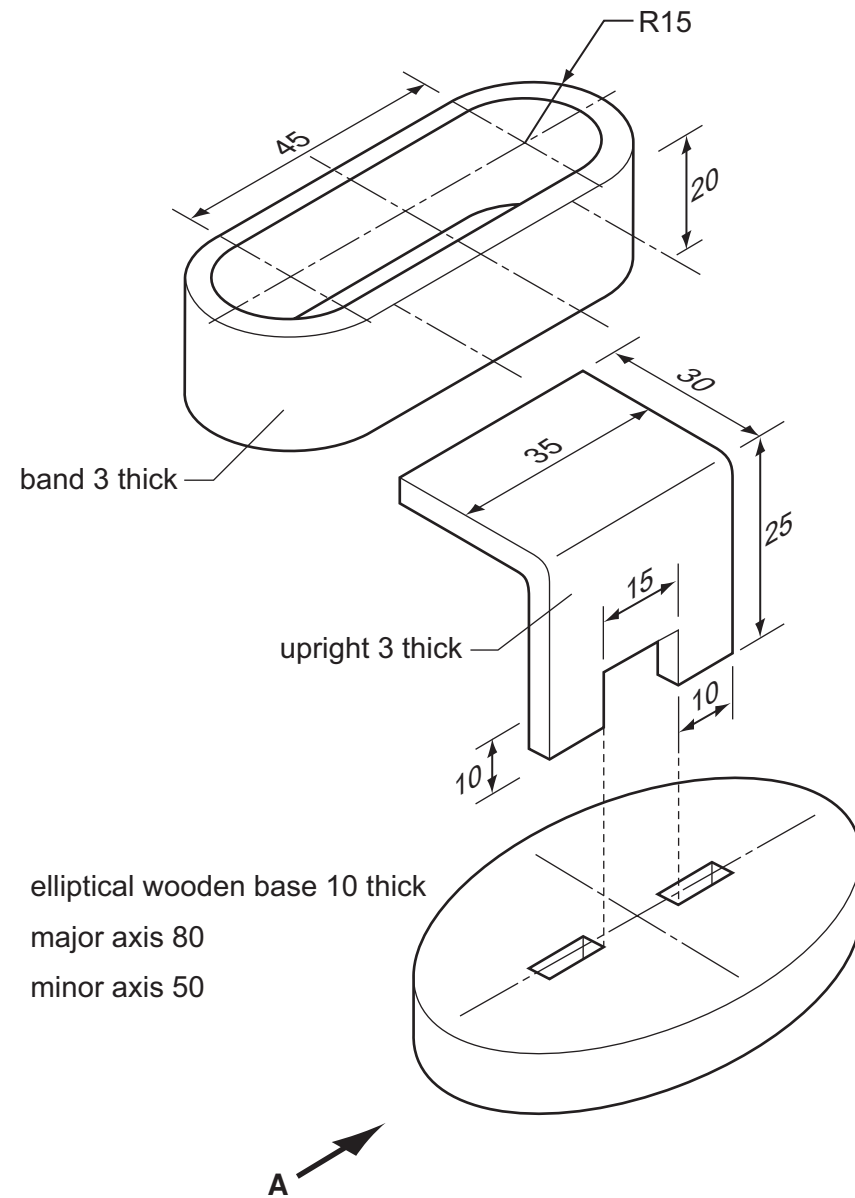

In the space given to the right, draw the following full size views.

- (a) A fully assembled front elevation of the display stand looking in the direction of arrow **A**. [13]
- (b) A plan of the assembly projected from the front elevation. [8]
- (c) An end elevation of the fully assembled display stand. [4]