

Section A

Answer **all** questions in this section.

A local swimming club is called LEANDER S.C.

The details of the club logo and signboard are shown below.

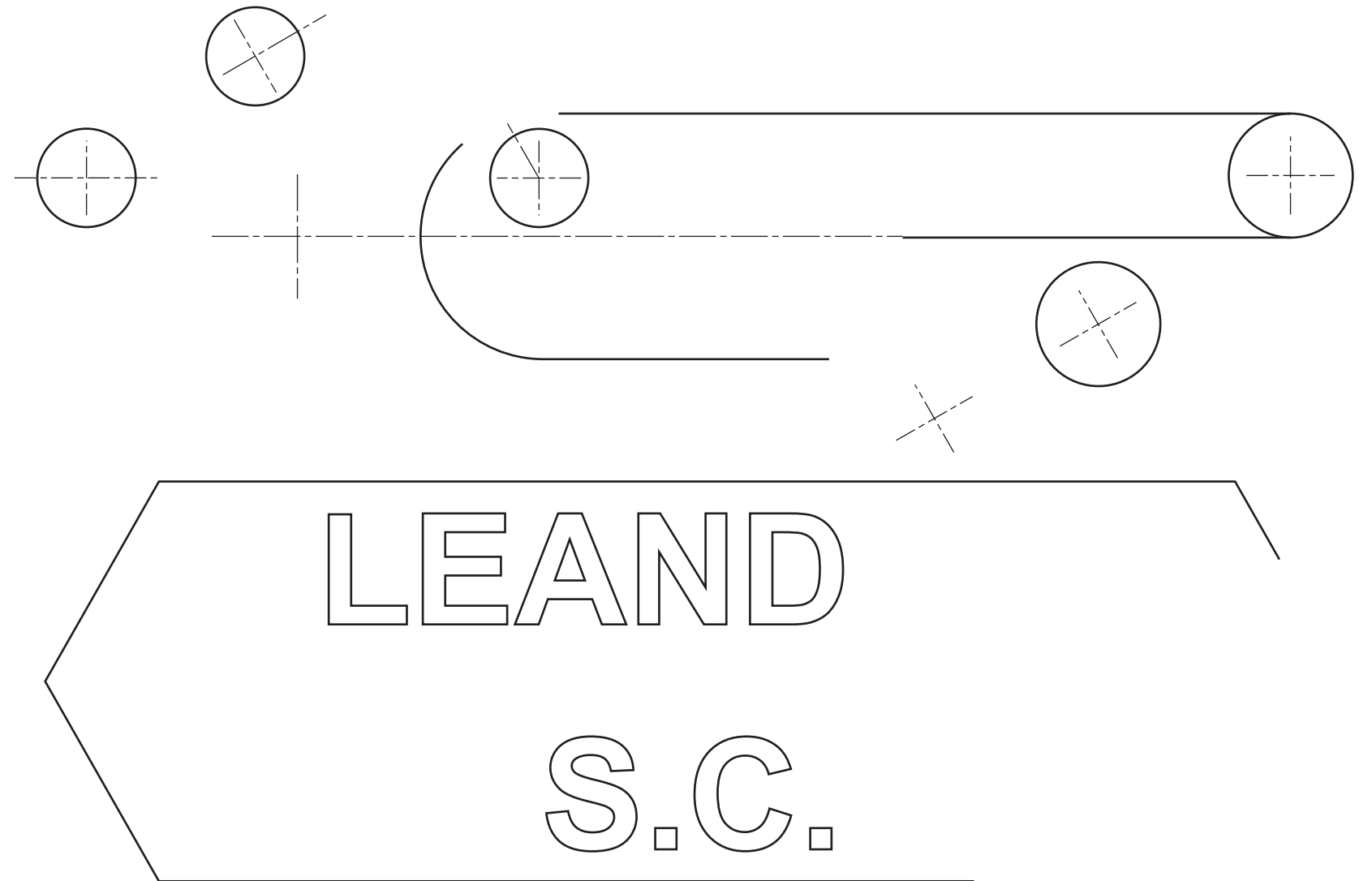
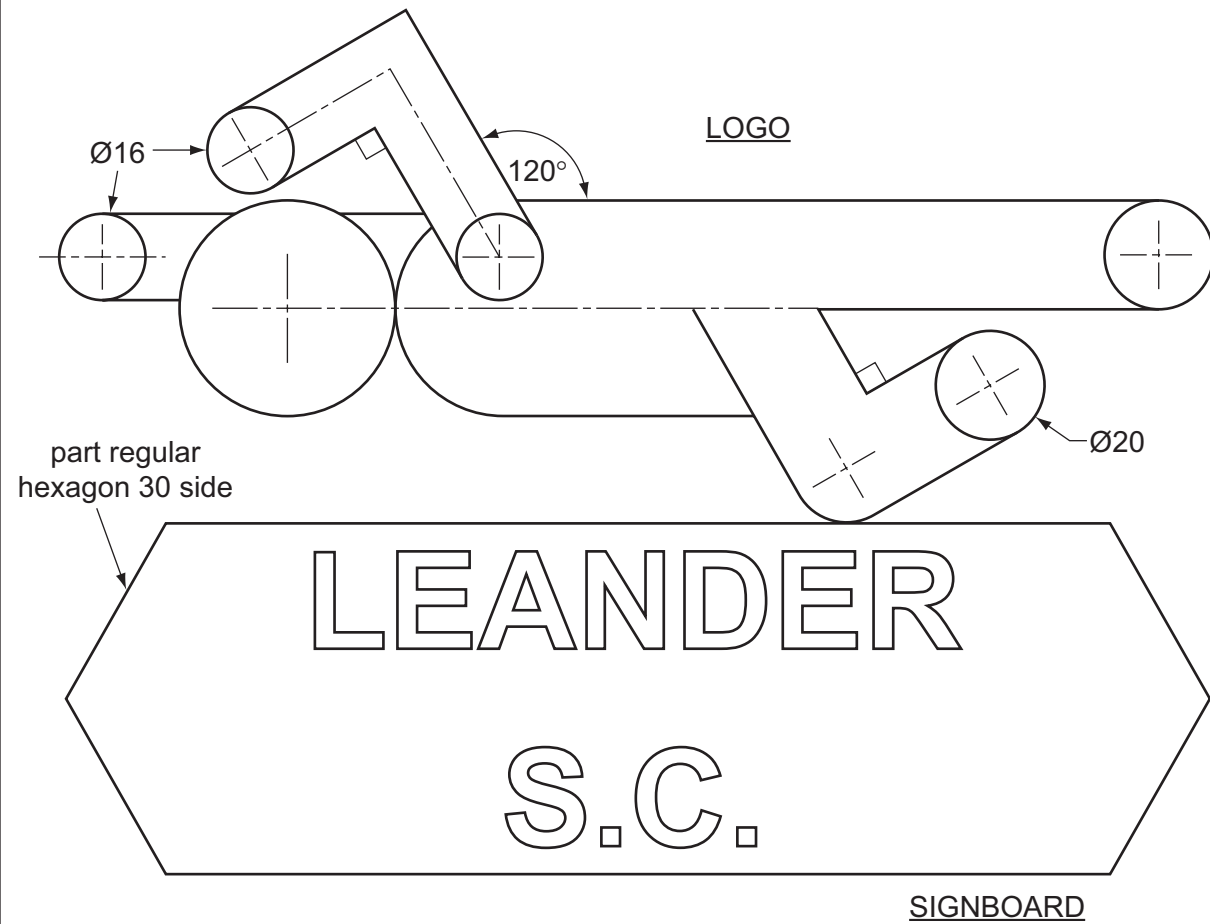

A1 Complete the full-size view of the logo in the space provided to the right by drawing:

- (a) the $\text{Ø}40$ head and horizontal arm of the swimmer; [3]
- (b) the raised arm connecting the shoulder to the hand; [3]
- (c) the bent leg of the swimmer. [3]

A2 Complete the signboard for LEANDER S.C. by:

- (a) adding the **two** missing letters; [4]
- (b) completing the outline so that the shape is symmetrical. [2]

All the letters must be to the same height and style as those given.

For
Examiner's
use

0445/21 Oct/Nov 2013 **1 hour**
© UCLES 2013

Centre Number

Candidate's Number

Candidate's Surname

Other Names

[Turn over

A3 Drawn below are details of a trophy intended for the best time in the 100 m freestyle. The trophy is made up from regular geometrical shapes.

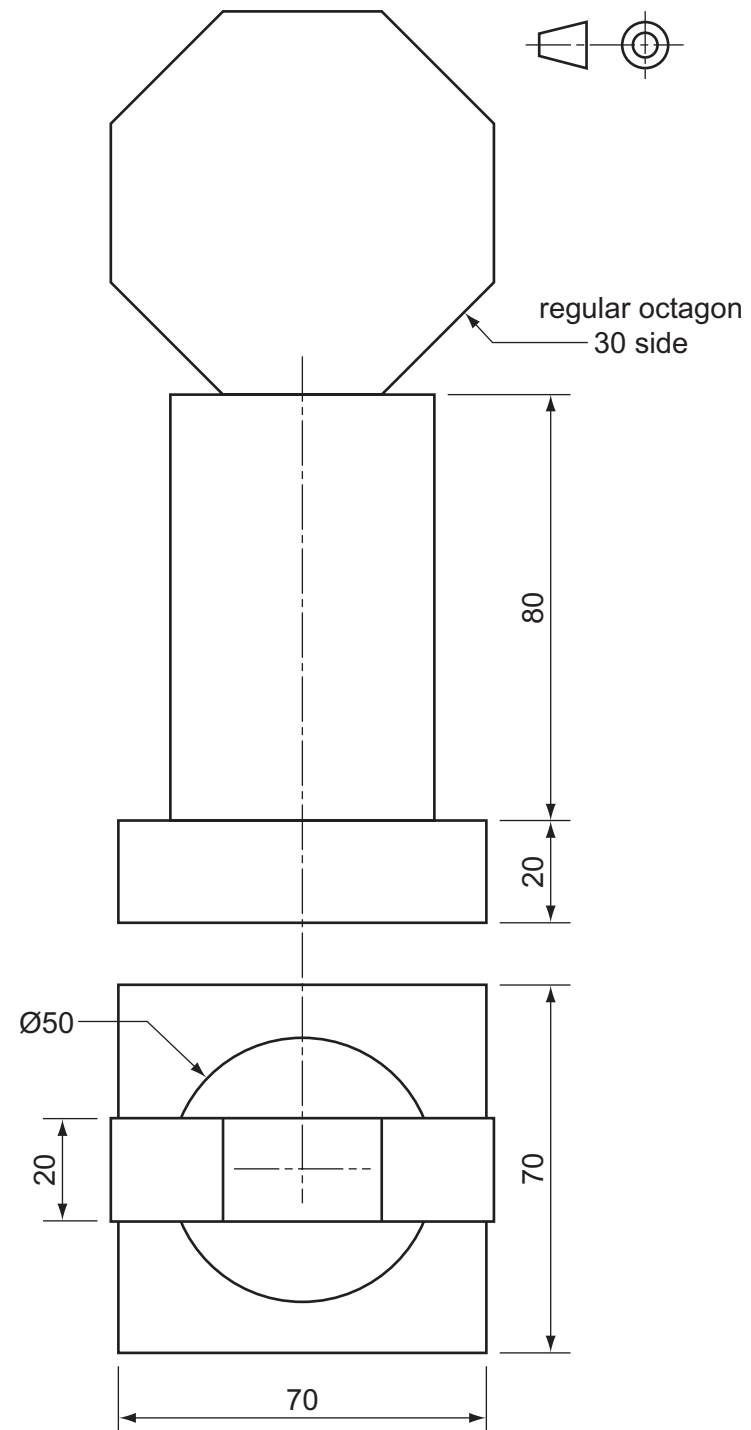

(a) In the space to the right, draw a full-size isometric view of the trophy. [8]

(b) Apply thick and thin line technique to the regular octagon **only**, to enhance its appearance. [2]

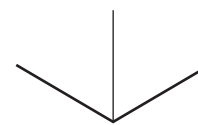

Section B

Answer **either** question **B4** or **B5**.

B4 The sketch below shows a prize-draw ticket box used at the swimming club. The box is made from a one-piece development of thin card. Half of the box lid folds back to leave a half-elliptical shape for the word PRIZE.

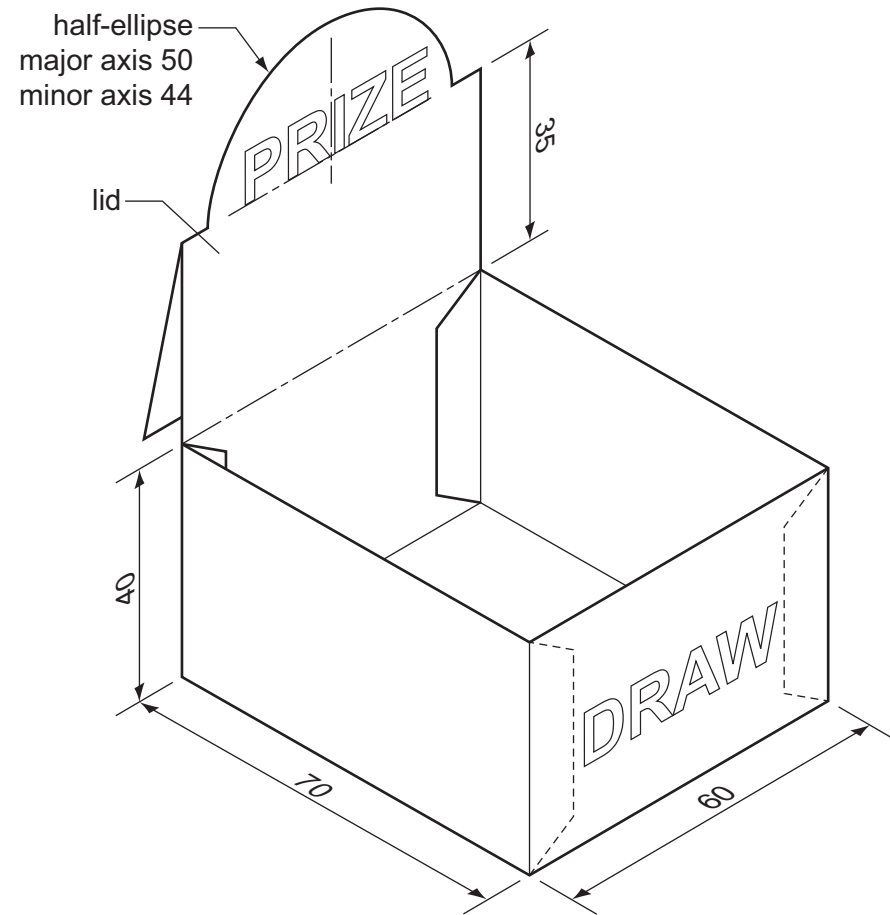

(a) In the space on the right, complete the drawing of a full-size, one-piece development (net) of the box. The front of the box and one glue tab have been started for you. Include the remaining glue tabs required to make the box. Print the word PRIZE in the correct orientation on the half-ellipse. [21]

(b) In the space below, use sketches and notes to show a method of holding the two halves of the folding lid together in the open position without using glue. [4]

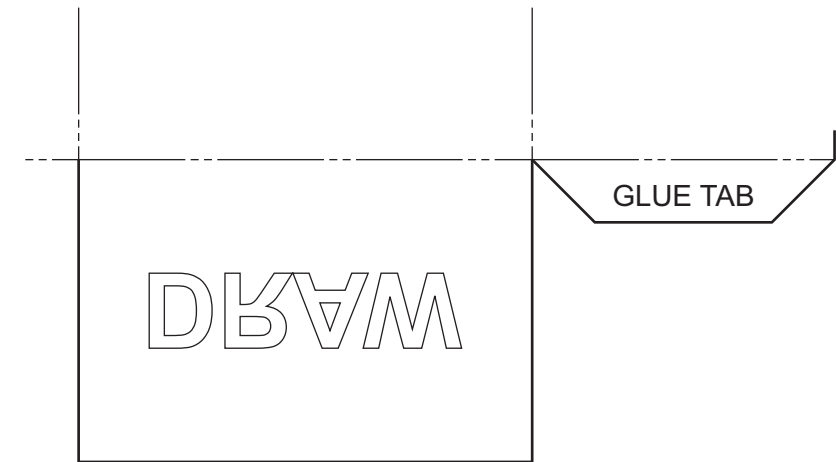

0445/21 Oct/Nov 2013 **1 hour**
© UCLES 2013

Centre Number

Candidate's Number

Candidate's Surname

Other Names

[Turn over]

