



Cambridge International Examinations
Cambridge International General Certificate of Secondary Education

CANDIDATE NAME

CENTRE NUMBER

CANDIDATE NUMBER



DESIGN AND TECHNOLOGY

0445/32

Paper 3 Resistant Materials

October/November 2014

1 hour

Candidates answer on the Question Paper.

No Additional Materials are required.

To be taken together with Paper 1 in one session of 2 hours 15 minutes.

READ THESE INSTRUCTIONS FIRST

Write your Centre number, candidate number and name on all the work you hand in.

Write in blue or black pen.

You may use an HB pencil for any diagrams, graphs or rough working.

Do not use staples, paper clips, glue or correction fluid.

DO NOT WRITE IN ANY BARCODES.

Section A

Answer **all** questions in this section.

Section B

Answer **one** question in this section.

You may use a calculator.

The total of the marks for this paper is 50.

The number of marks is given in brackets [] at the end of each question or part question.

| For Examiner's Use | |
|--------------------|--|
| Section A | |
| Section B | |
| Total | |

This document consists of **15** printed pages and **1** blank page.

Section A

Answer **all** questions in this section.

1 Fig. 1 shows waste wood being cut out.

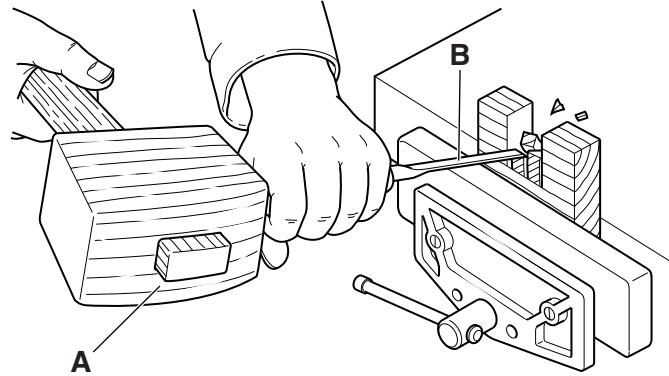

Fig. 1

Name each tool labelled **A** and **B** in Fig. 1.

A

B [2]

2 Fig. 2 shows a butt joint being glued and nailed.

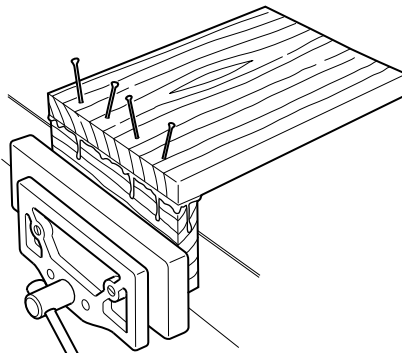

Fig. 2

(a) Name the method of nailing shown in Fig. 2.

..... [1]

(b) Give **one** reason why the nails are put in at an angle.

..... [1]

(c) Name a suitable adhesive.

..... [1]

3 Fig. 3 shows a small plastic dish.

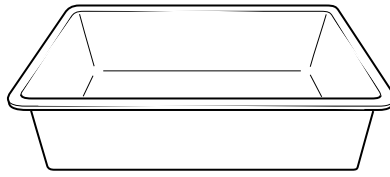

Fig. 3

(a) Name a process that could be used to produce the dish.

..... [1]

(b) Name a suitable plastic from which the dish could be made using the process named in (a).

..... [1]

4 A list of metals is given below.

copper

cast iron

stainless steel

duralumin

From the list of metals select:

(a) a ferrous alloy;

..... [1]

(b) a non-ferrous alloy.

..... [1]

5 Fig. 4 shows the end grain of a piece of solid wood being planed.

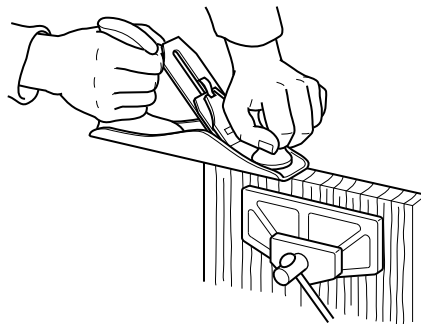
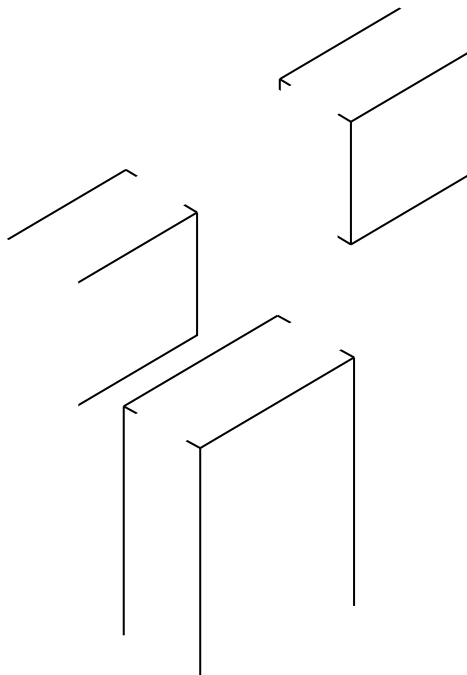

Fig. 4

Describe how the planing should be completed without splitting the end grain.

.....
.....
..... [2]

6 Complete the drawing below to show a tee brace joint.



[3]

7 Complete the table below by giving a specific name and a specific use for each saw.

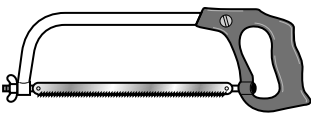
| Tool | Specific name | Specific use |
|---|---------------|--------------|
|  | | |
|  | | |

[4]

8 Fig. 5 shows a wheelbarrow. The body of the wheelbarrow is made from mild steel.

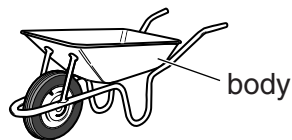

Fig. 5

(a) Give **one** reason why the body of the wheelbarrow would need a surface finish.

..... [1]

(b) Name a suitable surface finish for the body of the wheelbarrow.

..... [1]

9 (a) Complete the drawing below to show a back flap hinge.

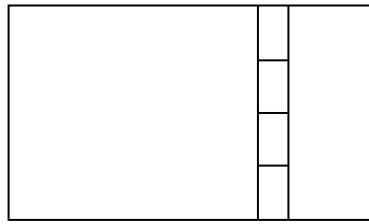

[2]

(b) Give **one** advantage of a back flap hinge over a butt hinge.

..... [1]

10 Fig. 6 shows a marking knife.

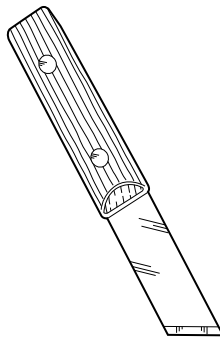

Fig. 6

(a) Describe **one** situation where a marking knife would be used to mark out wood rather than a pencil.

..... [1]

(b) Name **one** other marking out tool that scores/cuts the surface of the wood.

..... [1]

Section B

Answer **one** question from this section.

11 Fig. 7 shows a toy boat made mainly from wood.

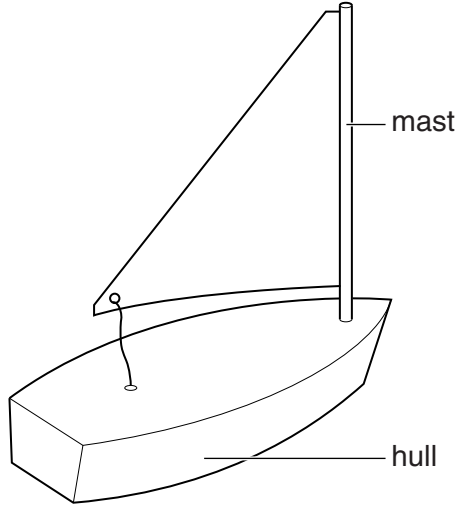

Fig. 7

(a) The mast is made from round section wood.

(i) Give the technical term for round section wood.

..... [1]

(ii) Name a waterproof adhesive that could be used to fix the mast into the hull.

..... [1]

(b) Give **two** reasons why a template would be useful to mark out the shape of the hull.

1

2 [2]

(c) Fig. 8 shows the hull of the toy boat marked out on a block of wood.

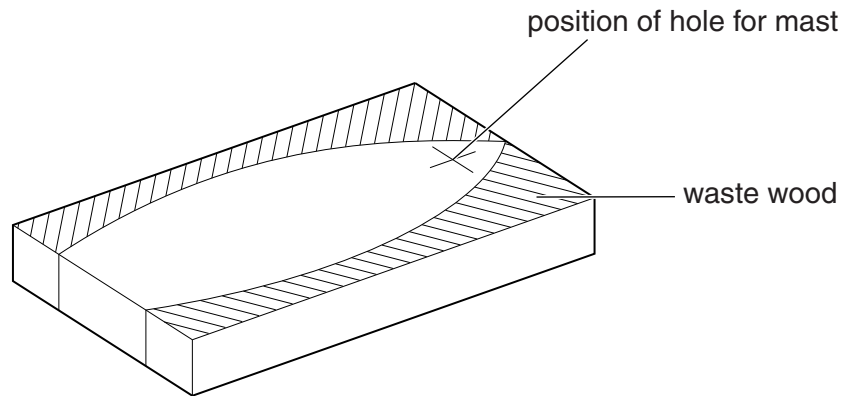

Fig. 8

Complete the table below by naming **one** tool or item of equipment used for each process.

| Stage | Process | Tool or item of equipment |
|-------|----------------------------|---------------------------|
| 1 | Cut off the waste | |
| 2 | Make the hole for the mast | |
| 3 | Make edges smooth | |

[3]

(d) Fig. 9 shows part of the hull and rudder.

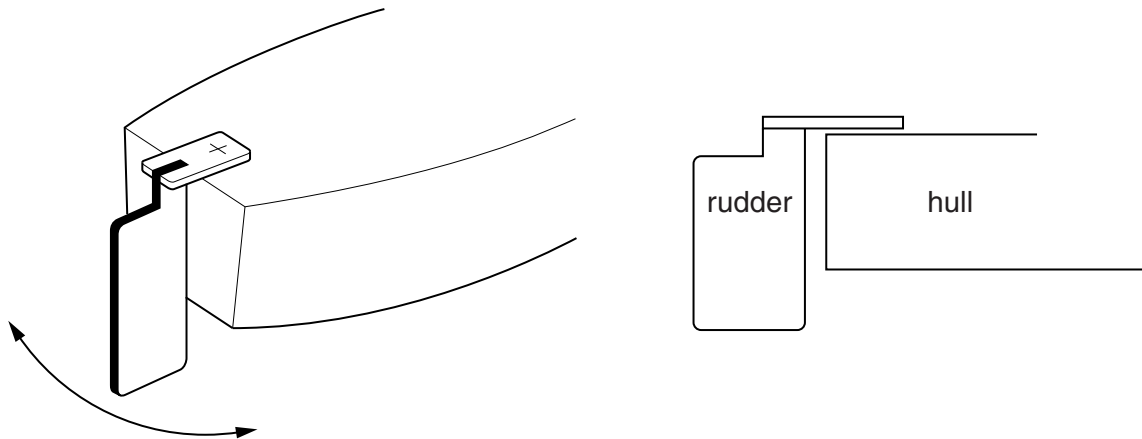

Fig. 9

Add sketches and notes to Fig. 9 to show how the rudder could be fitted to the hull and be able to move from side to side.

[2]

- (e) Fig. 10 shows a different design for a toy boat.
The toy boat has a vacuum formed hull and a separate deck made from polystyrene.

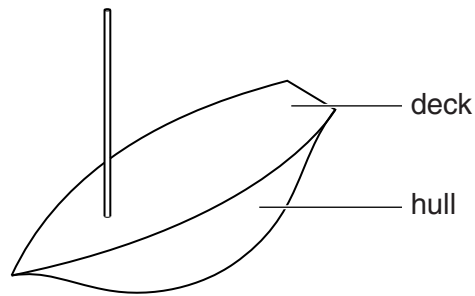

Fig. 10

Give **two** properties of polystyrene that makes it suitable for the toy boat.

1

2 [2]

- (f) Fig. 11 shows the separate parts of the hull and deck.

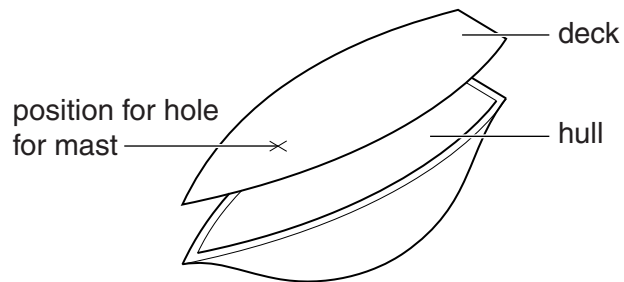

Fig. 11

Use sketches and notes to show how the hull would be vacuum formed.

(g) Use sketches and notes to show how the deck would be secured while drilling the hole for the mast.

[2]

(h) Give **two** safety precautions you must take when using polystyrene cement to join the deck to the hull.

1

2 [2]

(i) Describe **two** ways by which designers make toys appealing to young children.

1

2 [2]

- 12 Fig. 12 shows a tray table.
The tray is made from MDF and the stand could be made from **either** square section wood **or** square metal tube.

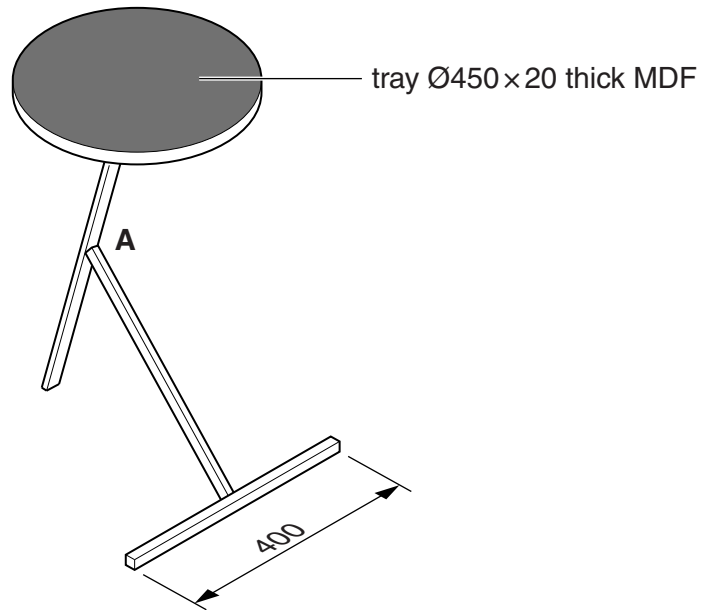

Fig. 12

- (a) (i) Use sketches and notes to show a method of construction at **A** if the stand was made from square section wood.

[3]

- (ii) Explain why a sliding bevel would be a useful tool to mark out part of the construction at **A**.

.....
.....
..... [2]

- (b) (i) The stand could be made from square metal tube.
State a suitable standard size of square metal tube.

..... [1]

- (ii) Use sketches and notes to describe how the construction at **A** would be brazed if the stand was made from square metal tube.

[6]

- (c) Use sketches and notes to show how the stand could be fixed to the underside of the tray.
You may choose to make the stand in square section wood **or** square metal tube.

[6]

- (d) Starting with the MDF block shown below, use sketches and notes to show how the tray could be produced.

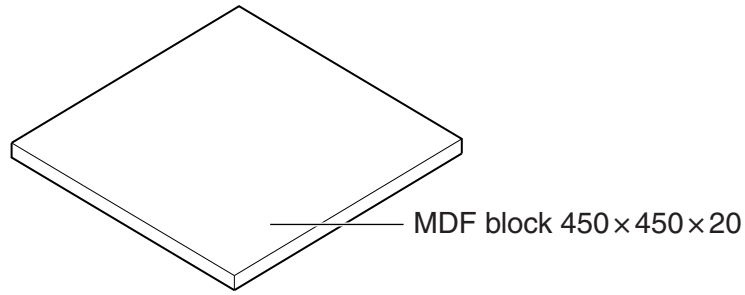

[4]

- (e) The surface of the tray is covered with a plastic laminate.

- (i) Give **two** benefits of covering the MDF tray with a plastic laminate.

1

2 [2]

- (ii) Name a suitable adhesive to join the plastic laminate to the MDF.

..... [1]

13 Fig. 13 shows a desk tidy made from two parts, tray A and tray B. Both trays are made from 6mm thick MDF.

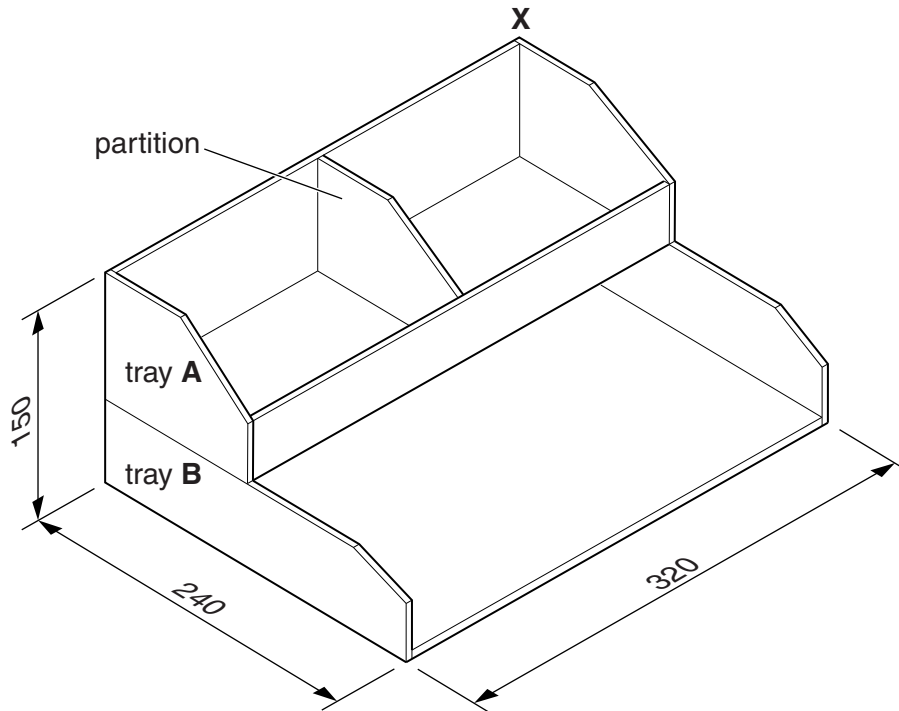

Fig. 13

(a) Give **two** advantages of MDF compared with other manufactured boards.

1

2 [2]

(b) Give **two** items of research a designer would need to consider when designing the desk tidy.

1

2 [2]

(c) (i) Use sketches and notes to show how a 6 mm thick MDF base could be fitted to tray A. The edges of the base must not be visible.

[3]

- (ii) Use sketches and notes to show how the partition in tray **A** could be fixed to the sides and base.

[3]

- (d) Use sketches and notes to show how tray **A** could be made to stack on top of tray **B** safely and securely. It must be easy to remove tray **A** from tray **B**. Include constructional details and sizes.

[5]

- (e) (i) Name a suitable finish for the desk tidy.

..... [1]

- (ii) Describe how you would prepare the MDF to take your chosen finish.

.....
.....
..... [2]

(f) The MDF used for the desk tidy is only 6 mm thick.
Use sketches and notes to show a suitable corner joint at **X**.

[3]

(g) Describe **two** functional improvements to the desk tidy shown in Fig. 13.

1

2 [2]

(h) Many desk tidies are made from plastic.
Give **two** advantages of making a desk tidy from plastic rather than MDF.

1

2 [2]

BLANK PAGE

Permission to reproduce items where third-party owned material protected by copyright is included has been sought and cleared where possible. Every reasonable effort has been made by the publisher (UCLES) to trace copyright holders, but if any items requiring clearance have unwittingly been included, the publisher will be pleased to make amends at the earliest possible opportunity.

Cambridge International Examinations is part of the Cambridge Assessment Group. Cambridge Assessment is the brand name of University of Cambridge Local Examinations Syndicate (UCLES), which is itself a department of the University of Cambridge.