



CO-ORDINATED SCIENCES

0654/12

Paper 1 Multiple Choice

October/November 2015

45 minutes

Additional Materials: Multiple Choice Answer Sheet
Soft clean eraser
Soft pencil (type B or HB is recommended)



READ THESE INSTRUCTIONS FIRST

Write in soft pencil.
Do not use staples, paper clips, glue or correction fluid.
Write your name, Centre number and candidate number on the Answer Sheet in the spaces provided unless this has been done for you.
DO NOT WRITE IN ANY BARCODES.

There are **forty** questions on this paper. Answer **all** questions. For each question there are four possible answers **A, B, C** and **D**.
Choose the **one** you consider correct and record your choice in **soft pencil** on the separate Answer Sheet.

Read the instructions on the Answer Sheet very carefully.

Each correct answer will score one mark. A mark will not be deducted for a wrong answer.
Any rough working should be done in this booklet.
A copy of the Periodic Table is printed on page 20.
Electronic calculators may be used.

This document consists of **20** printed pages.

- 1 Which statement about the characteristics of living organisms is correct?
- A Excretion is the breakdown of molecules to release energy.
 - B Nutrition is the removal of excess substances, toxic materials and waste products.
 - C Respiration is the taking in of organic substances and mineral ions.
 - D Sensitivity is the ability to detect and respond to changes in the environment.
- 2 The diagram shows an alveolus and surrounding capillary.

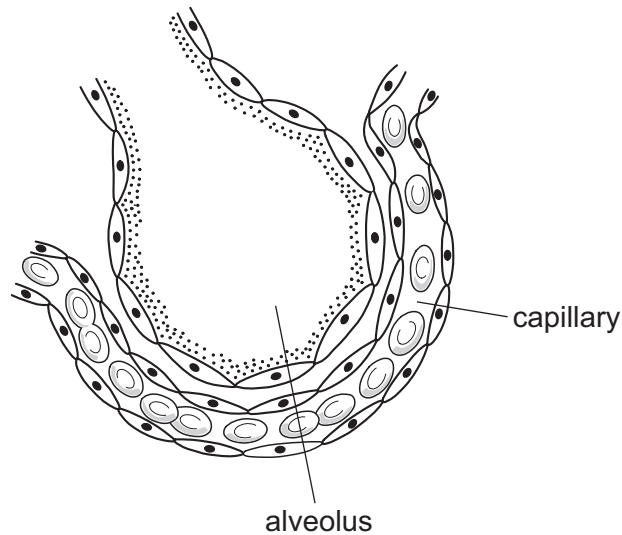

Why does oxygen move from the alveolus to the capillary?

- A Carbon dioxide molecules move from the capillary to the alveolus.
 - B Inspiration increases the pressure in the lung.
 - C The oxygen is absorbed by osmosis into the blood.
 - D There is an oxygen concentration gradient in this direction.
- 3 The diagram shows a plant cell.

Which labelled feature would also be found in an animal cell?

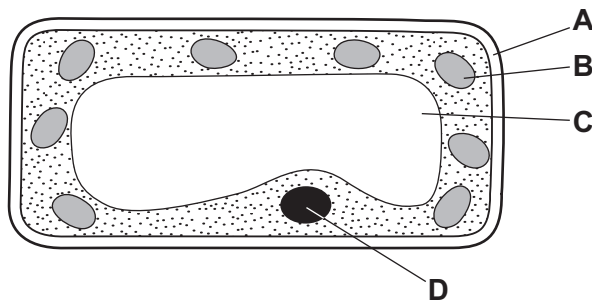

- 4 Eight test-tubes each containing a starch-saliva mixture are set up at four different temperatures.

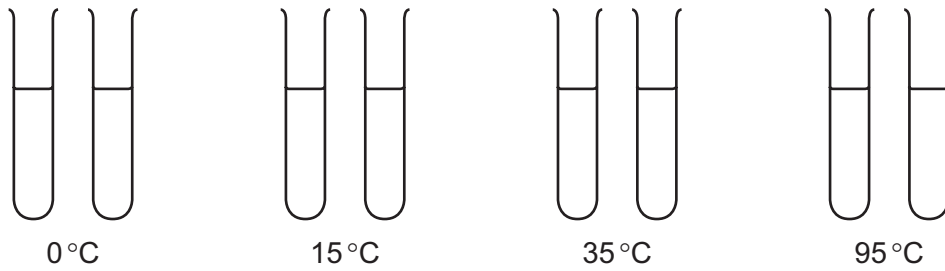

For each temperature, one test-tube is tested with iodine solution after 15 minutes, and the other after 30 minutes.

The results are shown in the table.

temperature /°C	colour with iodine solution	
	15 minutes	30 minutes
0	blue-black	blue-black
15	blue-black	brown
35	brown	brown
95	blue-black	blue-black

What do the results suggest?

- A** The enzyme in saliva is inactive at 95°C.
- B** The enzyme in saliva is slow to work at 35°C.
- C** The enzyme in saliva works equally well at 15°C and 35°C.
- D** The enzyme in saliva works faster at higher temperatures.

5 The diagram shows a section through a leaf.

Where are carbohydrates made?

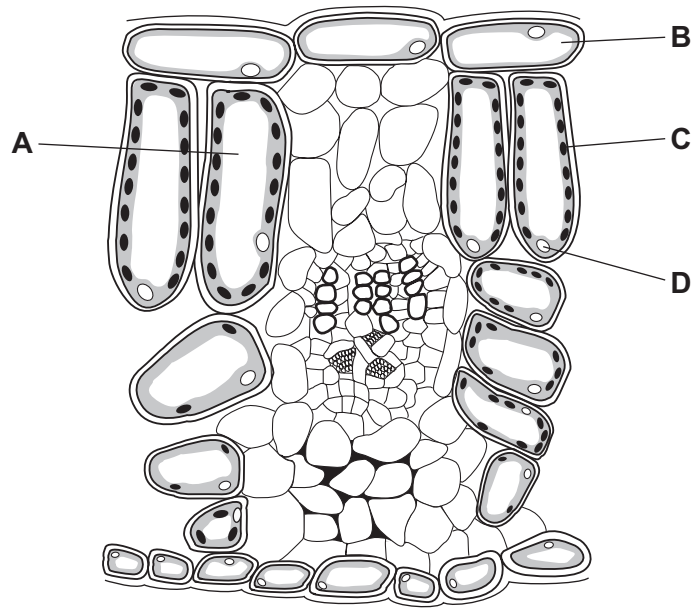

6 The diagram shows the heart, liver and kidneys with connecting blood vessels.

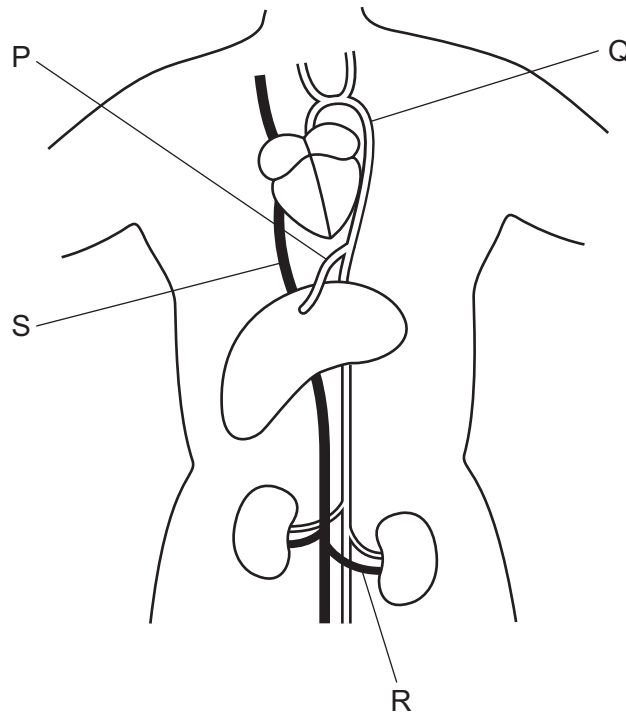

What are the labelled blood vessels?

	aorta	hepatic artery	vena cava	renal vein
A	Q	P	S	R
B	Q	R	S	P
C	S	P	Q	R
D	S	R	Q	P

7 Which part of the alimentary canal is in the form of a coiled tube?

- A oesophagus
- B pancreas
- C rectum
- D small intestine

8 In a full set of adult human teeth, there will be the **smallest** number of

- A canines.
- B incisors.
- C molars.
- D premolars.

9 Which area represents the substances produced in aerobic respiration?

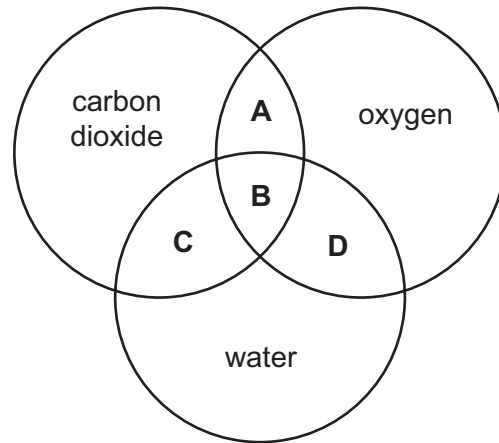

10 The diagram shows the male reproductive system.

Which structure produces the hormones that control adolescence?

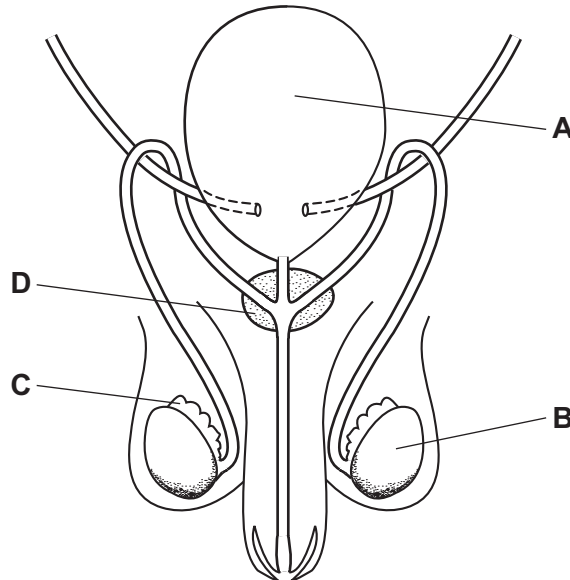

11 What is the effect of adrenaline?

	blood glucose concentration	rate of heart beat
A	decrease	decrease
B	decrease	increase
C	increase	decrease
D	increase	increase

- 12 Which chemical supplies carnivores with energy and plays a part in the carbon cycle?
- A carbon dioxide
 B fibre (roughage)
 C glucose
 D water
- 13 What is an effect of increased methane in the atmosphere?
- A a decrease in soil erosion
 B an increase in new plant species
 C the cooling of the Earth's atmosphere
 D the melting of the polar ice caps
- 14 The structures of some substances are shown.

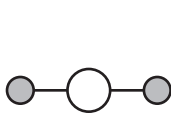

water

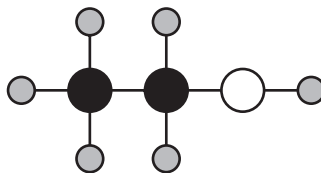

ethanol

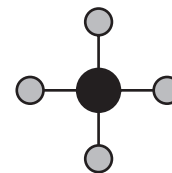

methane

Which row shows the total number of different elements and the total number of atoms in the three structures?

	total number of different elements	total number of atoms
A	3	9
B	3	17
C	7	9
D	7	17

15 Hexane and octane are liquid hydrocarbons that mix together.

Which method is used to separate a mixture of these two liquids?

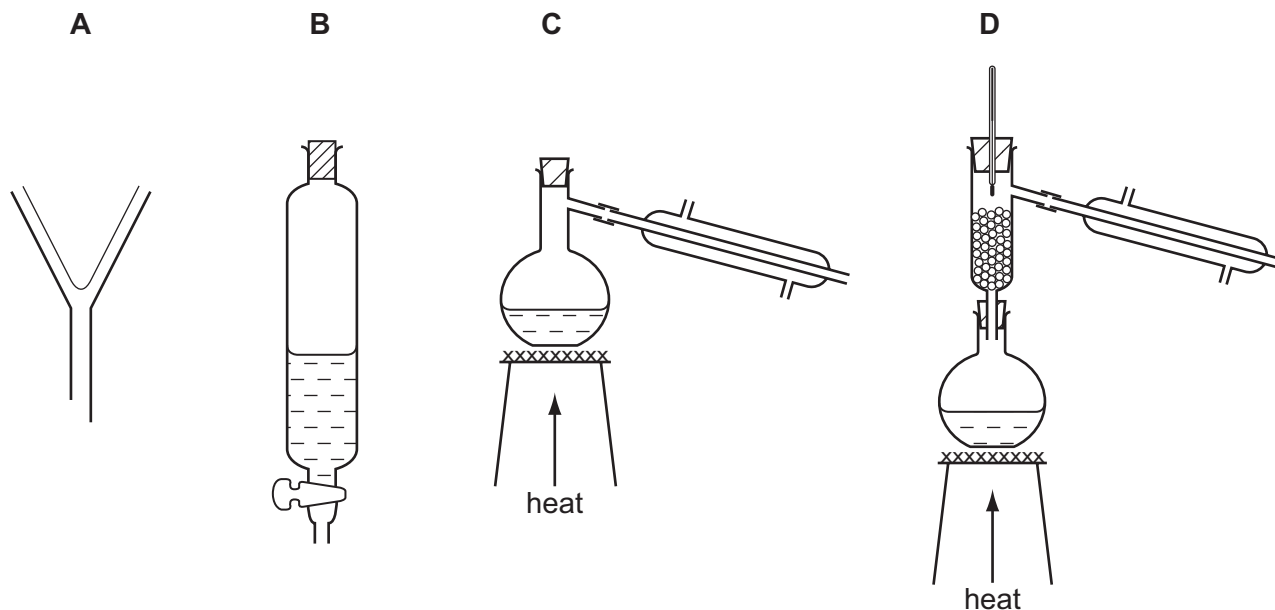

16 The diagram shows a helium atom.

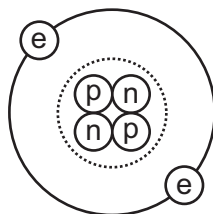

Which particles in the helium atom have approximately the same mass?

- A electron and proton only
- B electron and neutron only
- C proton and neutron only
- D electron, proton and neutron

17 Which changes are chemical changes?

- 1 conversion of steam to liquid water
- 2 cracking of alkanes
- 3 fractional distillation of petroleum
- 4 strongly heating calcium carbonate

- A 1 and 3
- B 1 and 4
- C 2 and 3
- D 2 and 4

18 The diagram shows a molecule of propane.

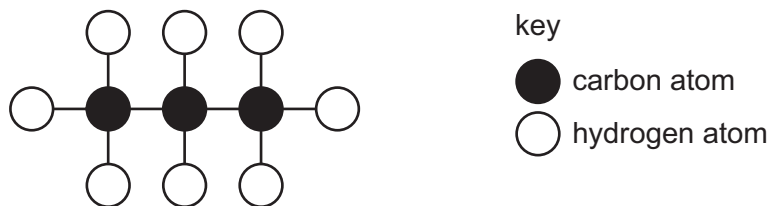

What is the formula of propane and to which homologous series does propane belong?

	formula	homologous series
A	C_3H_6	alkane
B	C_3H_6	alkene
C	C_3H_8	alkane
D	C_3H_8	alkene

19 The diagram shows the electrolysis of lead(II) bromide using inert electrodes.

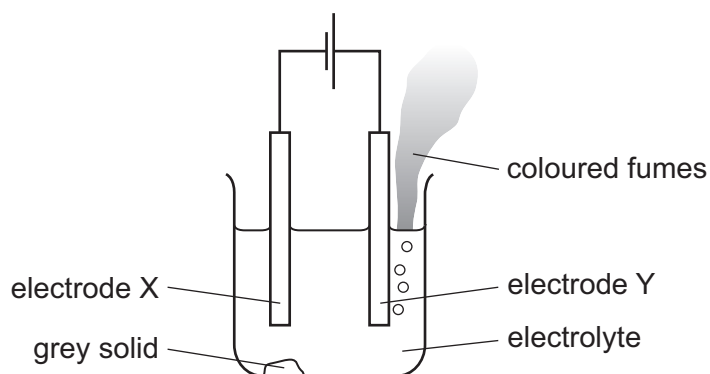

Which statement about this experiment is correct?

- A** Electrode X is positively charged.
- B** The coloured fumes are produced at the negative electrode.
- C** The electrolyte is lead(II) bromide.
- D** The grey solid is lead(II) bromide.

20 Lime is manufactured by heating limestone.

Lime is used to control the acidity of soil.

Which types of chemical change occur in these two reactions?

	heating limestone	controlling acidity
A	endothermic	oxidation
B	endothermic	neutralisation
C	exothermic	oxidation
D	exothermic	neutralisation

21 Nitrogen from the air is used to manufacture ammonia.



Why is a catalyst used in this reaction?

- A** Nitrogen from the air is not pure.
- B** Nitrogen is a gas at room temperature.
- C** Nitrogen is a non-metallic element.
- D** Nitrogen is not very reactive.

22 Sulfuric acid and sodium carbonate react and release a colourless gas.

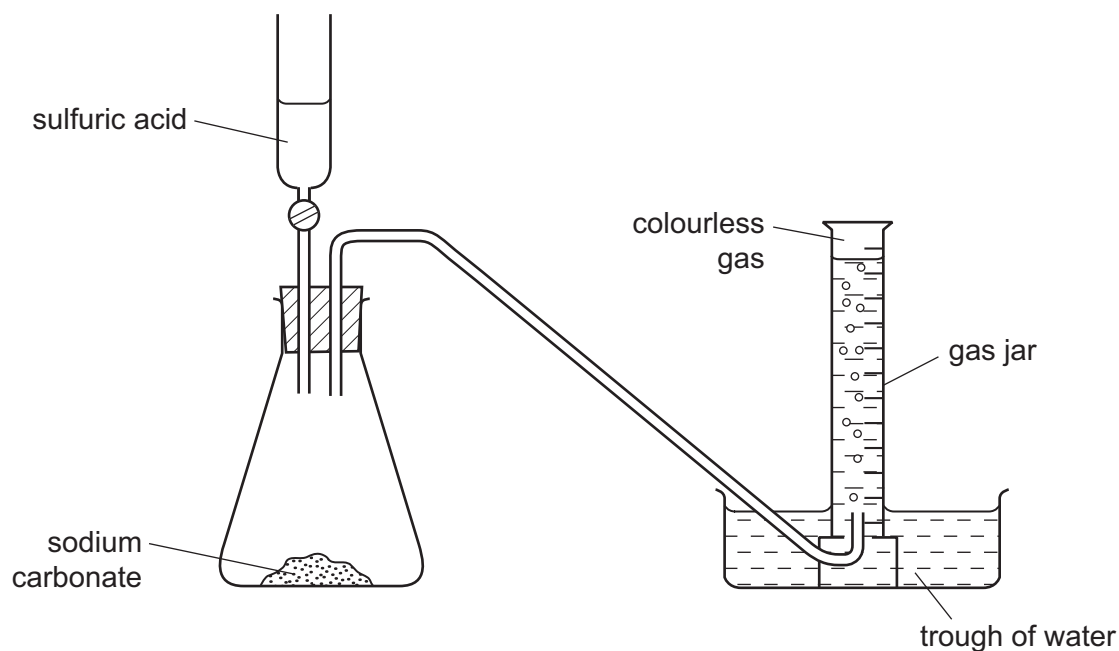

What is the gas?

- A carbon dioxide
- B hydrogen
- C hydrogen sulfide
- D sulfur dioxide

23 Which test and result identify aqueous ammonium ions?

	test	result
A	add aqueous sodium hydroxide	blue precipitate
B	add aqueous sodium hydroxide	white precipitate
C	heat with aqueous sodium hydroxide	gas evolved turns damp red litmus paper blue
D	heat with aqueous sodium hydroxide and aluminium powder	gas evolved turns damp blue litmus paper red

24 An element is a solid at room temperature and does **not** conduct electricity.

What is the proton number of this element?

- A 11
- B 19
- C 35
- D 53

25 Metal X is extracted from its ore by heating the ore with carbon.

Which statement explains why carbon is used?

- A Carbon is a non-metal.
- B Carbon is more reactive than X.
- C Carbon reacts with oxygen in the air.
- D X is more reactive than carbon.

26 Which chemical is used to reduce the acidity of soil?

- A ammonium nitrate
- B calcium oxide
- C magnesium sulfate
- D potassium chloride

27 Poly(ethene) is made from ethene.

Ethene molecules are known as1..... and join together in a process known as2..... polymerisation.

Which words correctly complete gaps 1 and 2?

	1	2
A	monomers	addition
B	monomers	neutralisation
C	polymers	addition
D	polymers	neutralisation

28 The following are distance/time graphs.

Which graph shows an object moving at constant speed?

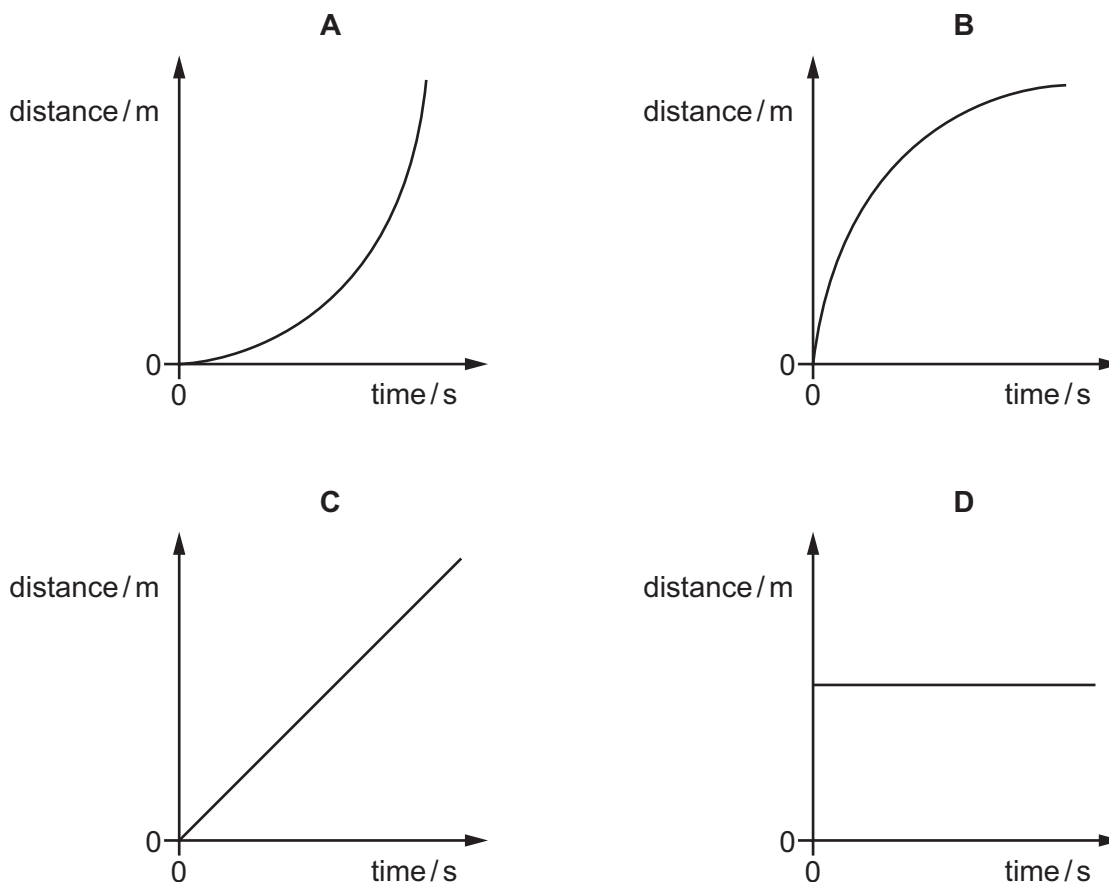

29 A large bag of feathers and a steel block balance each other on some scales.

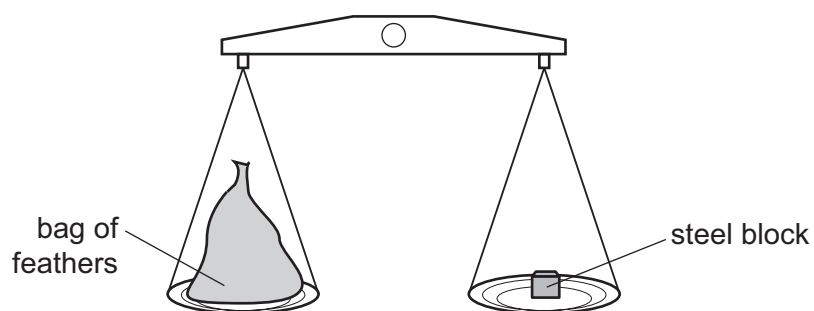

What does this show about the masses and the weights of the bag of feathers and the steel block?

- A The masses are equal and the weights are equal.
- B The masses are equal, but the weights are different.
- C The masses are different and the weights are different.
- D The weights are equal, but the masses might be different.

30 A student pours liquid into a measuring cylinder.

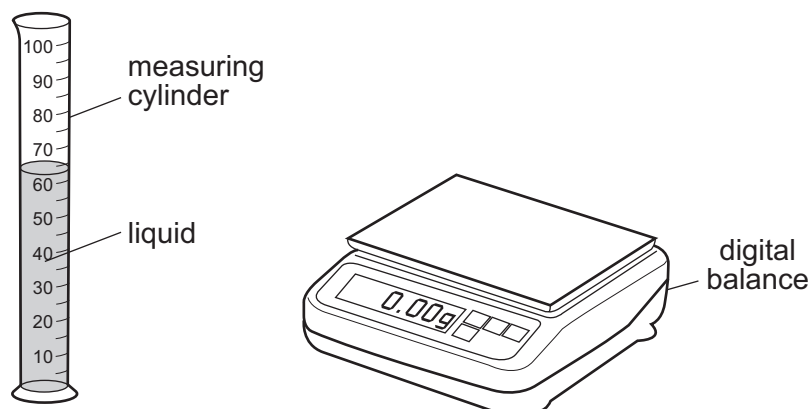

The student records the volume of the liquid from the scale on the measuring cylinder. He then puts the measuring cylinder containing the liquid on a balance and records the mass.

What else needs to be measured before the density of the liquid can be calculated?

- A the depth of the liquid in the measuring cylinder
- B the mass of the empty measuring cylinder
- C the temperature of the liquid in the measuring cylinder
- D the volume of the empty measuring cylinder

31 Electricity can be obtained from different energy resources.

Which energy resource is used to obtain electricity without producing heat to boil water?

- A coal
- B gas
- C hydroelectric
- D nuclear

32 Evaporation occurs when molecules escape from a liquid surface into the air above it. During this process the temperature of the liquid falls.

Why does the temperature of the liquid fall?

- A The molecules in the vapour expand because the pressure is less.
- B The molecules left in the liquid have more space to move around.
- C The molecules move more slowly when they escape into the air.
- D The molecules with the highest energies escape into the air.

33 A beaker containing ice and a thermometer is left in a warm room for 15 minutes.

There is no liquid water in the beaker until 5 minutes have passed. After 15 minutes some ice is still visible.

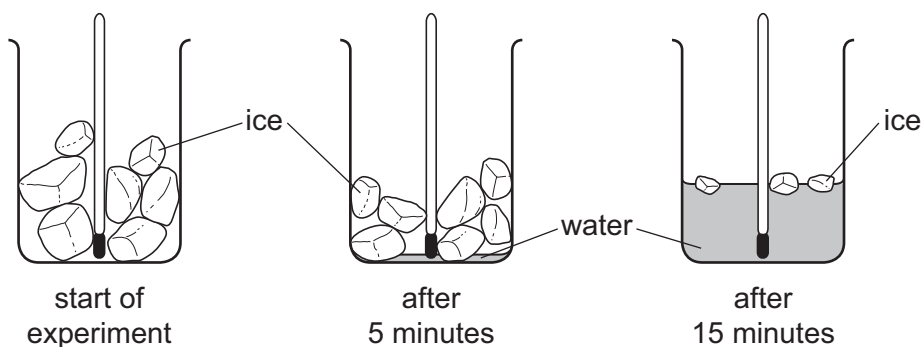

Which graph shows how the thermometer reading changes?

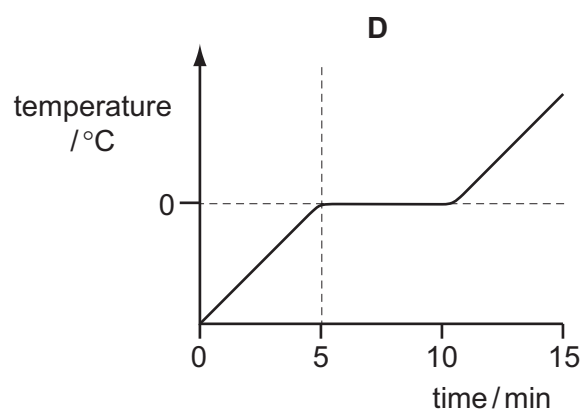
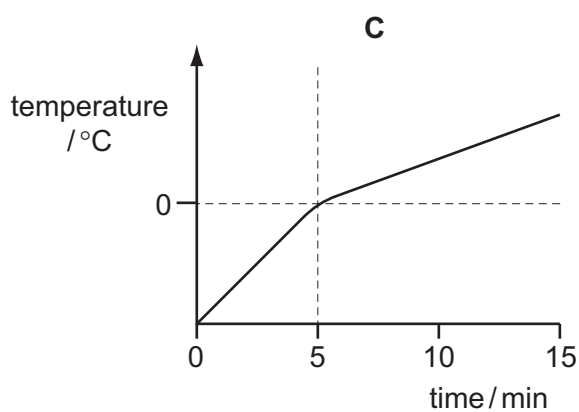
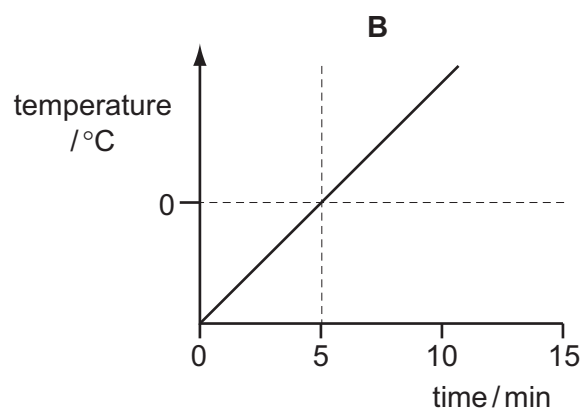
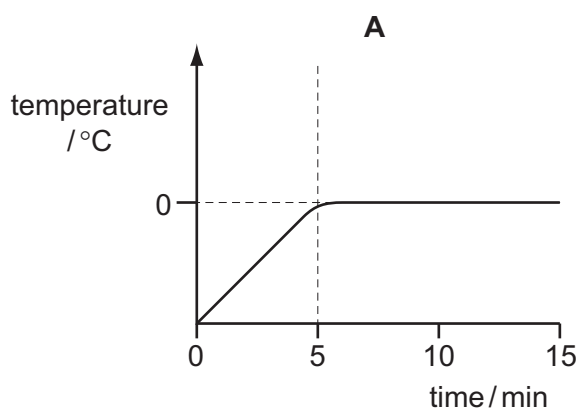

- 34 Hot liquid in a vacuum flask cools extremely slowly. This is because some methods of heat transfer do not take place in a vacuum.

Which methods do **not** take place in a vacuum?

- A conduction and convection only
- B conduction and radiation only
- C convection and radiation only
- D conduction, convection and radiation

- 35 The diagram shows a wave.

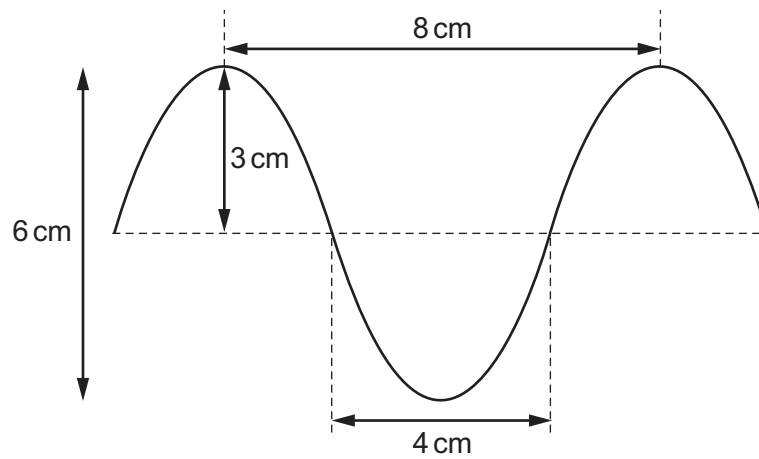

What are the amplitude and the wavelength of this wave?

	amplitude / cm	wavelength / cm
A	3	4
B	3	8
C	6	4
D	6	8

36 A piece of paper has 'PAL' written on it.

A student holds the paper in front of a plane mirror.

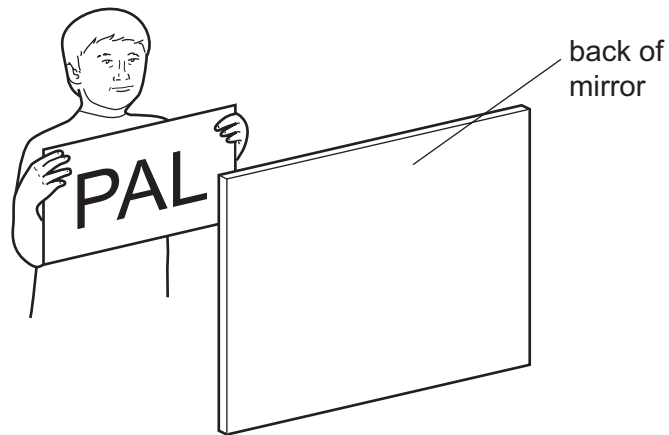

What does the student see?

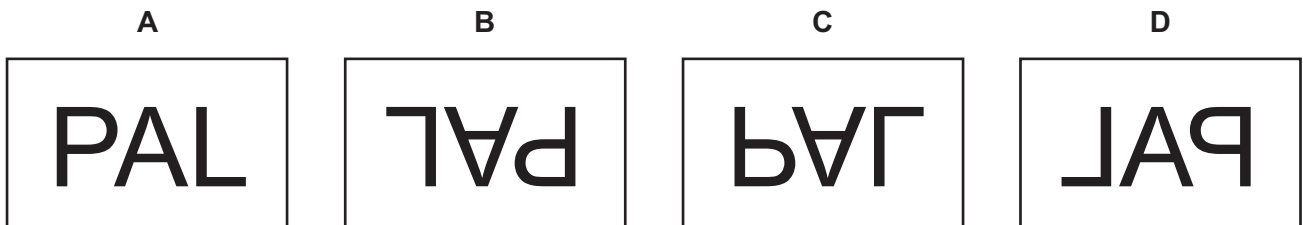

37 The horn on a ship is sounded. The captain hears an echo from a cliff 4.0 s later.

The speed of sound is 340 m/s.

How far away is the cliff?

- A 170 m B 340 m C 680 m D 1360 m

38 A student constructs four circuits, each containing a fuse.

The fuse blows in one circuit and both lamps in the circuit go out.

In which circuit does the fuse blow and both lamps go out?

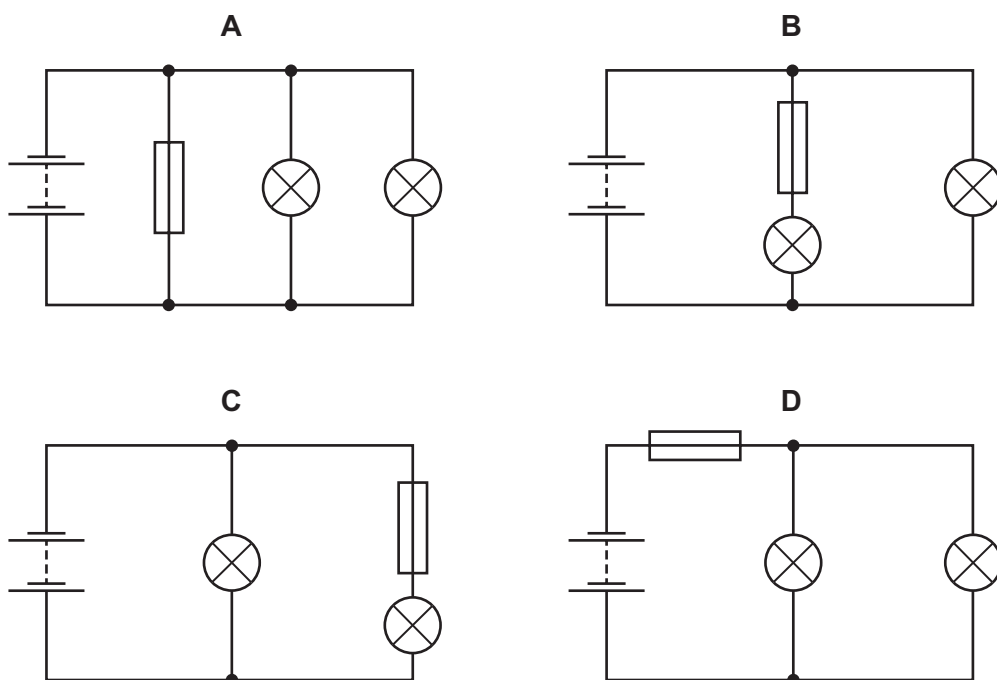

39 The diagram shows a series circuit that includes two ammeters P and Q and two voltmeters R and S.

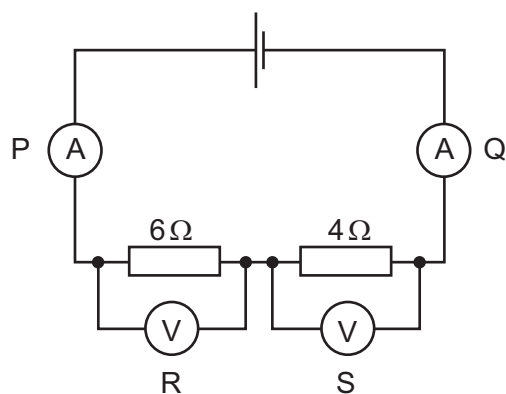

How do the readings on the meters in the circuit compare?

	reading on ammeter P	reading on voltmeter R
A	equal to reading on ammeter Q	greater than reading on voltmeter S
B	equal to reading on ammeter Q	less than reading on voltmeter S
C	greater than reading on ammeter Q	greater than reading on voltmeter S
D	greater than reading on ammeter Q	less than reading on voltmeter S

40 The table compares an atom of carbon-13 and an atom of nitrogen-14.

	carbon-13	nitrogen-14
nucleon number A	6	7
proton number Z	13	14

A neutral atom of carbon-13 and a neutral atom of nitrogen-14 have the same number of

- A electrons.
- B ions.
- C neutrons.
- D protons.

DATA SHEET

The Periodic Table of the Elements

Group																		
I	II											III	IV	V	VI	VII	0	
												1 H Hydrogen 1						4 He Helium 2
7 Li Lithium 3	9 Be Beryllium 4											11 B Boron 5	12 C Carbon 6	14 N Nitrogen 7	16 O Oxygen 8	19 F Fluorine 9	20 Ne Neon 10	
23 Na Sodium 11	24 Mg Magnesium 12											27 Al Aluminium 13	28 Si Silicon 14	31 P Phosphorus 15	32 S Sulfur 16	35.5 Cl Chlorine 17	40 Ar Argon 18	
39 K Potassium 19	40 Ca Calcium 20	45 Sc Scandium 21	48 Ti Titanium 22	51 V Vanadium 23	52 Cr Chromium 24	55 Mn Manganese 25	56 Fe Iron 26	59 Co Cobalt 27	59 Ni Nickel 28	64 Cu Copper 29	65 Zn Zinc 30	70 Ga Gallium 31	73 Ge Germanium 32	75 As Arsenic 33	79 Se Selenium 34	80 Br Bromine 35	84 Kr Krypton 36	
85 Rb Rubidium 37	88 Sr Strontium 38	89 Y Yttrium 39	91 Zr Zirconium 40	93 Nb Niobium 41	96 Mo Molybdenum 42	96 Tc Technetium 43	101 Ru Ruthenium 44	103 Rh Rhodium 45	106 Pd Palladium 46	108 Ag Silver 47	112 Cd Cadmium 48	115 In Indium 49	119 Sn Tin 50	122 Sb Antimony 51	128 Te Tellurium 52	127 I Iodine 53	131 Xe Xenon 54	
133 Cs Caesium 55	137 Ba Barium 56	139 La Lanthanum 57 *	178 Hf Hafnium 72	181 Ta Tantalum 73	184 W Tungsten 74	186 Re Rhenium 75	190 Os Osmium 76	192 Ir Iridium 77	195 Pt Platinum 78	197 Au Gold 79	201 Hg Mercury 80	204 Tl Thallium 81	207 Pb Lead 82	209 Bi Bismuth 83	209 Po Polonium 84	210 At Astatine 85	222 Rn Radon 86	
223 Fr Francium 87	226 Ra Radium 88	227 Ac Actinium 89 †																

*58-71 Lanthanoid series

†90-103 Actinoid series

Key	a	a = relative atomic mass
	X	X = atomic symbol
	b	b = proton (atomic) number

140 Ce Cerium 58	141 Pr Praseodymium 59	144 Nd Neodymium 60	147 Pm Promethium 61	150 Sm Samarium 62	152 Eu Europium 63	157 Gd Gadolinium 64	159 Tb Terbium 65	162 Dy Dysprosium 66	165 Ho Holmium 67	167 Er Erbium 68	169 Tm Thulium 69	173 Yb Ytterbium 70	175 Lu Lutetium 71
232 Th Thorium 90	231 Pa Protactinium 91	238 U Uranium 92	237 Np Neptunium 93	244 Pu Plutonium 94	243 Am Americium 95	247 Cm Curium 96	247 Bk Berkelium 97	251 Cf Californium 98	252 Es Einsteinium 99	257 Fm Fermium 100	258 Md Mendelevium 101	259 No Nobelium 102	260 Lr Lawrencium 103

The volume of one mole of any gas is 24 dm³ at room temperature and pressure (r.t.p.).