



**Cambridge International Examinations**  
Cambridge International General Certificate of Secondary Education

CANDIDATE  
NAME

--

CENTRE  
NUMBER

--	--	--	--	--

CANDIDATE  
NUMBER

--	--	--	--



**CO-ORDINATED SCIENCES**

**0654/22**

Paper 2 (Core)

**October/November 2015**

**2 hours**

Candidates answer on the Question Paper.

No Additional Materials are required.

**READ THESE INSTRUCTIONS FIRST**

Write your Centre number, candidate number and name on all the work you hand in.

Write in dark blue or black pen.

You may use an HB pencil for any diagrams, graphs, tables or rough working.

Do not use staples, paper clips, glue or correction fluid.

**DO NOT WRITE IN ANY BARCODES.**

Answer **all** questions.

Electronic calculators may be used.

You may lose marks if you do not show your working or if you do not use appropriate units.

A copy of the Periodic Table is printed on page 32.

At the end of the examination, fasten all your work securely together.

The number of marks is given in brackets [ ] at the end of each question or part question.

This document consists of **29** printed pages and **3** blank pages.

1 Fig. 1.1 shows a compost bin. Gardeners use these bins to produce compost which is a useful fertiliser for plants.

They put weeds, dead leaves and other garden waste into the bin. Over time, these break down to produce the fertiliser.

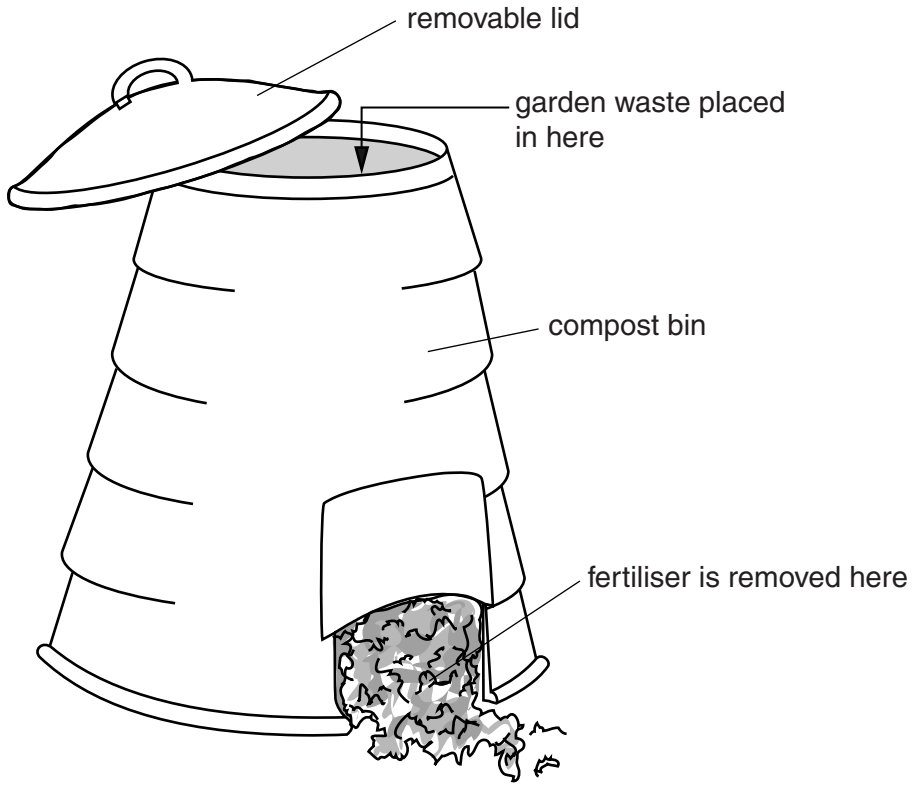

Fig. 1.1

(a) Name the process that breaks down the garden waste into fertiliser for plants.

.....[1]

(b) The organisms that break down the garden waste are respiring aerobically.

(i) Name **two** substances that they would produce in their respiration.

1 .....

2 .....[2]

(ii) Name **two** mineral ions that the fertiliser will contain.

1 .....

2 .....[2]

(iii) Suggest **two** things that a gardener could do to help the organisms in the compost bin to respire more quickly.

1 .....

2 .....[2]

(c) Greenhouse gases are released as the compost is produced in the bin.

(i) State the name of a greenhouse gas.

.....[1]

(ii) Describe the environmental effect of increased amounts of greenhouse gases in the atmosphere.

.....

.....[1]

- 2 (a) A student carries out an experiment to investigate the reactivities of metals.

She adds dilute hydrochloric acid to four test-tubes each containing one of the four metals, calcium, copper, magnesium and zinc.

- (i) Name the gas produced when metals react with dilute hydrochloric acid.

.....[1]

- (ii) Describe a test and its result for the gas you have named in (i).



test .....

result .....[2]

- (iii) The student's observations are shown in Table 2.1.

Complete the table by writing the names of the four metals, calcium, copper, magnesium and zinc into the correct boxes.

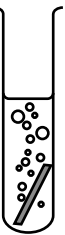
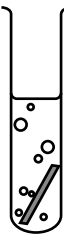
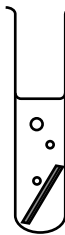
**Table 2.1**

observation				
metal	.....	.....	.....	.....

[2]

- (iv) Explain why potassium and sodium must **not** be included in this investigation.

.....  
 .....  
 .....[2]

(b) Fig. 2.1 shows a ring made of an alloy of gold.

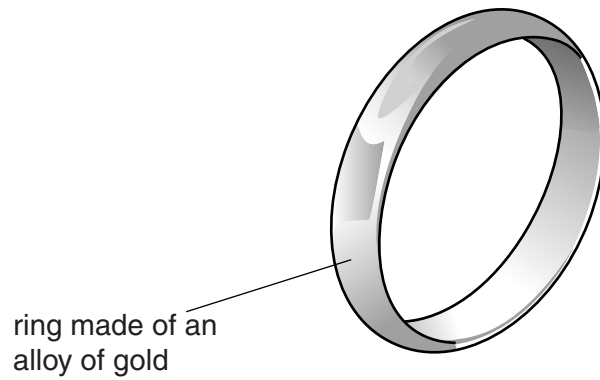

**Fig. 2.1**

Alloys of gold usually cost less than pure gold.

Suggest **one** other advantage of making a ring from an alloy of gold rather than pure gold.

.....  
.....[1]

- 3 (a) Fig. 3.1 shows a speed/time graph for a train.

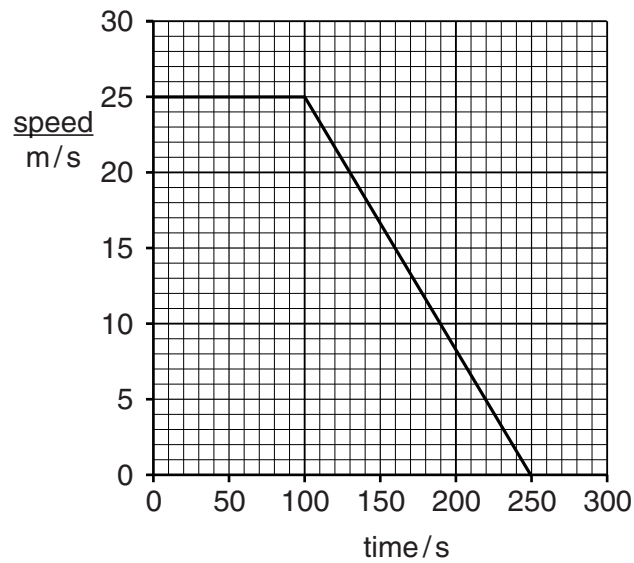

**Fig. 3.1**

- (i) Describe the motion of the train over the first 100 seconds.

.....[1]

- (ii) On Fig. 3.1, mark with an **X** the point at which the train stops moving. [1]

- (b) Fig. 3.2 shows some of the forces acting on the train.

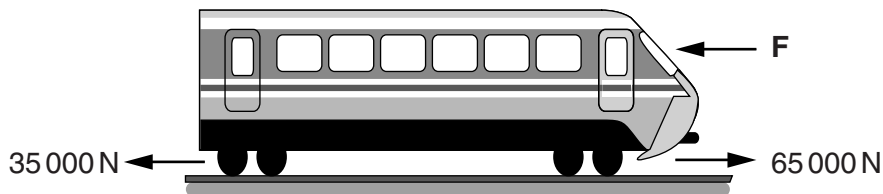

**Fig. 3.2**

The engine of the train produces a thrust of 65 000 N. There is a 35 000 N force opposing the motion due to friction in the wheels.

The train is travelling at a constant speed.

- (i) Force **F** is another force opposing the motion due to friction.

Suggest what is causing this force.

.....[1]

- (ii) The train travels at a constant speed. Calculate the size of force **F**.

Show your working.

force = ..... N [1]

- (c) The engine is powered by diesel fuel. The combustion of diesel fuel releases energy, which is transformed into kinetic energy.

- (i) State the form of energy stored in a fuel.

.....[1]

- (ii) Only 20% of the energy stored in the diesel fuel is transformed into kinetic energy. The rest of the energy is transformed into other forms of energy.

State **one** of these other forms of energy.

.....[1]

- (d) The track for the train is composed of short lengths of steel rails with small gaps left between them. This is shown in Fig. 3.3.

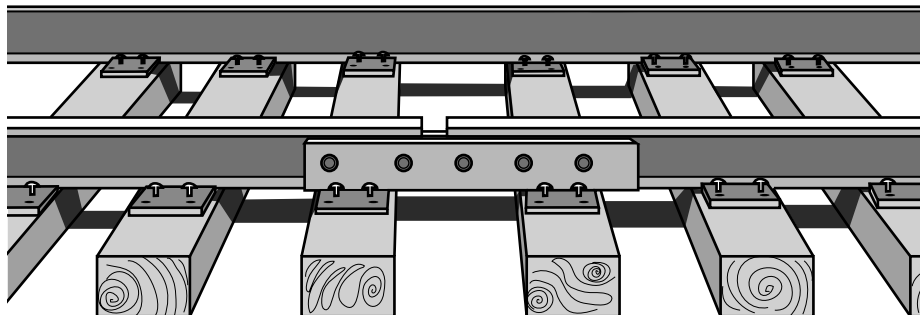

**Fig. 3.3**

Suggest the reason for leaving these small gaps.

.....  
 .....  
 .....[2]

(e) The steel rails are made from steel blocks. Each block is a cube, with sides of 0.5 m. The density of steel is  $7800 \text{ kg/m}^3$ .

(i) Calculate the volume of a steel block in  $\text{m}^3$ .

Show your working.

volume = .....  $\text{m}^3$  [1]

(ii) Calculate the mass of the block of steel in kilograms.

State the formula that you use and show your working.

formula

working

mass = ..... kg [2]



4 Fig. 4.1 shows a liquid fossil fuel being extracted from rock layers beneath the sea bed.

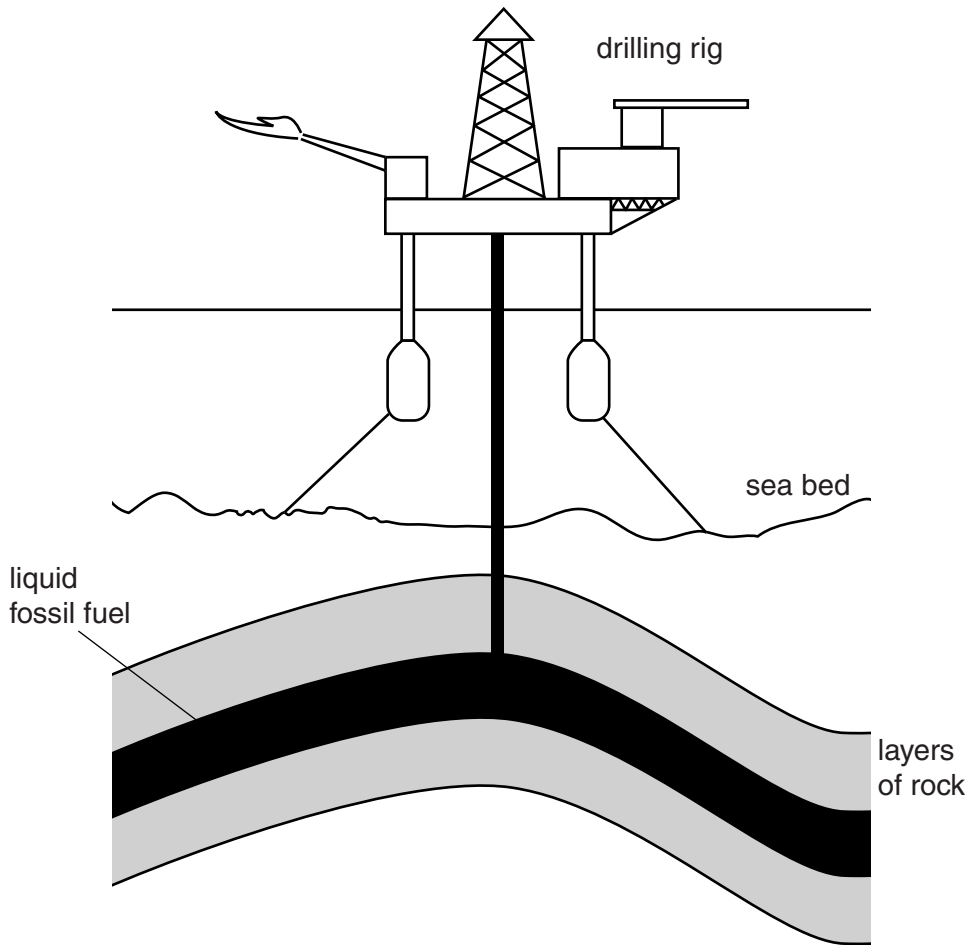

**Fig. 4.1**

**(a)** Name the fossil fuel being extracted.

.....[1]

- (b) The material extracted from the rock is a mixture of hydrocarbons.

Fig. 4.2 shows a simplified diagram of industrial apparatus being used to separate simpler mixtures, **P** and **Q**, from the fossil fuel.

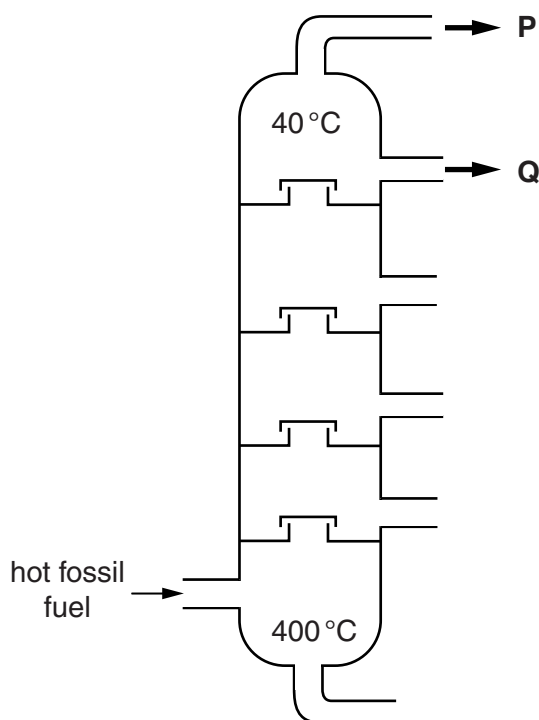

**Fig. 4.2**

- (i) Name the process shown in Fig. 4.2.

.....[1]

- (ii) Mixture **P** is gaseous.

State **one** use for mixture **P**.

.....[1]

- (iii) Mixture **Q** is liquid and used as car fuel.

Name mixture **Q**.

.....[1]

(c) Fig. 4.3 shows the structure of a hydrocarbon molecule.

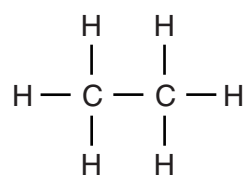

**Fig. 4.3**

(i) State the chemical formula and name of the hydrocarbon shown in Fig. 4.3.

chemical formula .....

name .....

[2]

(ii) Draw the structure of an **unsaturated** hydrocarbon molecule that has the same number of carbon atoms as the molecule in Fig. 4.3.

[2]

- (d) Fig. 4.4 shows a simplified diagram of an industrial process in which alkenes are produced from alkanes.

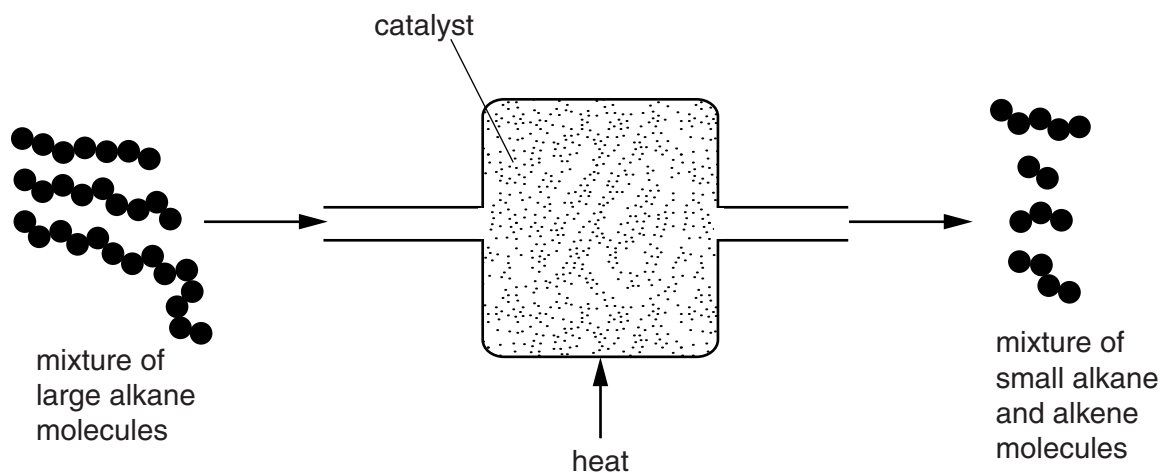

**Fig. 4.4**

- (i) Name the process shown in Fig. 4.4.

.....[1]

- (ii) Describe a chemical test used to distinguish between an alkane and an alkene.

test .....

.....

result for an alkane .....

.....

result for an alkene .....

.....

[3]

**Please turn over for Question 5.**

5 An athlete does a two-hour training session every day.

Fig. 5.1 shows how the amount of glycogen in his liver changed over a period of two days.

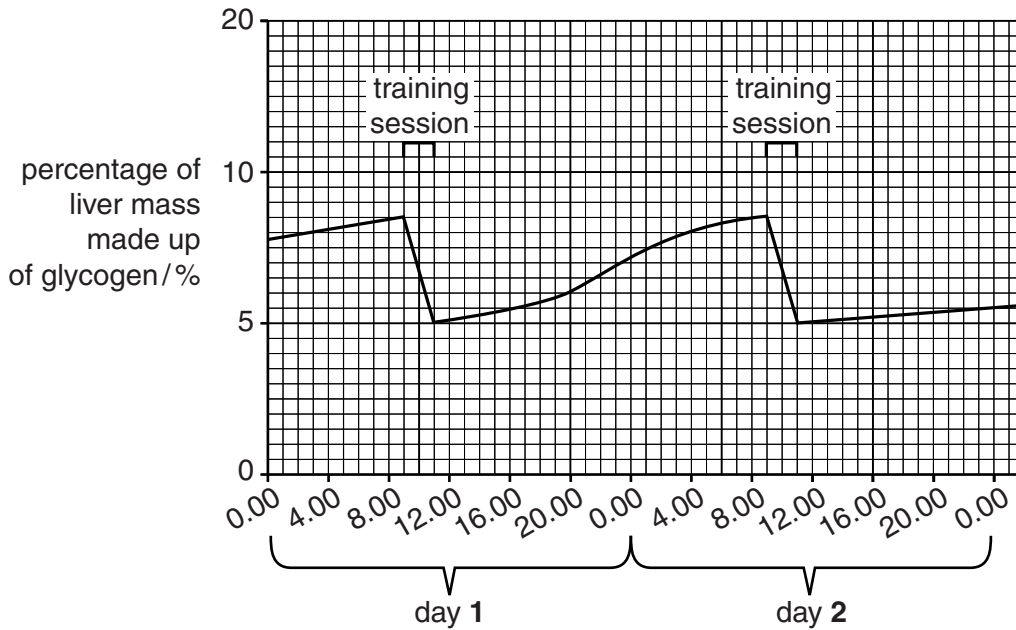

Fig. 5.1

(a) (i) For day 1, state the percentage of the liver mass that was made up of glycogen at the start of the training session,

.....

at the end of the training session.

.....

[2]

(ii) Explain why the amount of glycogen changed during the training sessions.

.....

.....

.....[2]

- (iii) The amount of glycogen in the liver changed between the two training sessions. Describe this change and explain why it happened.

description .....

.....

.....

explanation .....

.....

.....[3]

- (iv) Suggest an explanation for the different shape of the graph after the training session on day 2, compared to after the training session on day 1.

.....

.....

.....[1]

(b) Glycogen is a carbohydrate.

- (i) Name the chemical elements present in a carbohydrate.

.....

.....

..... [3]

- (ii) Name the smaller molecules that form the basic units of a large glycogen molecule.

.....[1]

(c) During a training session, the athlete will secrete adrenaline.

- (i) Suggest how the adrenaline would affect the amount of glycogen in the liver. Explain your answer.

.....

.....[1]

- (ii) State **one** other effect of adrenaline on the body.

.....

.....[1]

- 6 (a) A cyclist has a mirror placed on his handlebars so that he can see behind him.

The cyclist sees a taxi in his mirror as shown on Fig. 6.1.

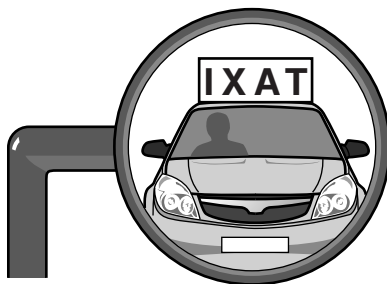

Fig. 6.1

Describe **two** characteristics of an image seen in a plane mirror.

- 1 .....
- 2 ..... [2]

- (b) A reflector on the back of the bicycle is made from many small glass prisms, one of which is shown in Fig. 6.2.

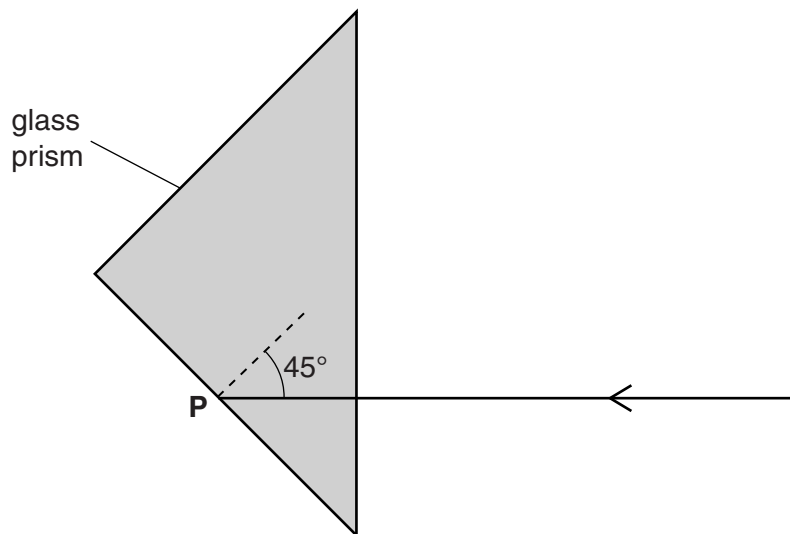

Fig. 6.2

A ray of light is incident on the back surface of the prism at point **P** at an angle of  $45^\circ$ .

The critical angle for glass is  $42^\circ$ .

- (i) Explain why light does not leave the prism at point **P**.

.....

..... [1]



(ii) On Fig. 6.2, draw the path of the ray of light as it leaves point **P** and travels through the glass and then back into the air again. [2]

(c) The air in a bicycle tyre exerts a pressure on the walls of the tyre.

Describe, in terms of particles, how a gas exerts a pressure on the walls of a tyre.

.....  
.....  
.....  
.....[2]

(d) As the cyclist rides, he cools down by sweating. The sweat evaporates from the surface of the cyclist's skin.

Explain, in terms of particles, why sweating cools the skin.

.....  
.....  
.....  
.....[2]

7 Fig. 7.1 shows the male reproductive system, as seen from the side.

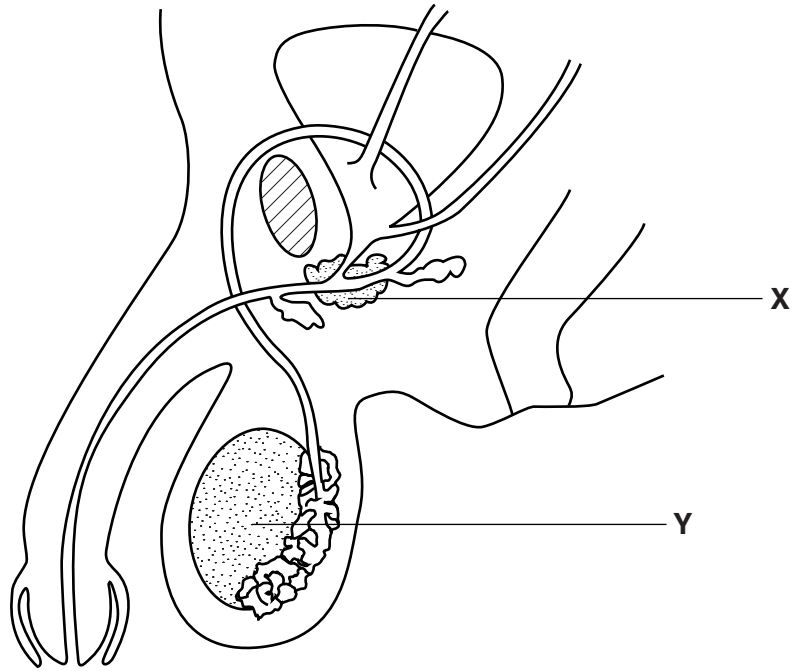

Fig. 7.1

(a) (i) On Fig. 7.1, label the urethra and the sperm duct. [2]

(ii) Name the structures labelled X and Y.

X .....

Y .....

[2]

(b) State **two** functions of the testes.

1 .....

2 ..... [2]

(c) Sperm cells are mobile (able to move). Fig. 7.2 shows how mobility of sperm cells varies with temperature.

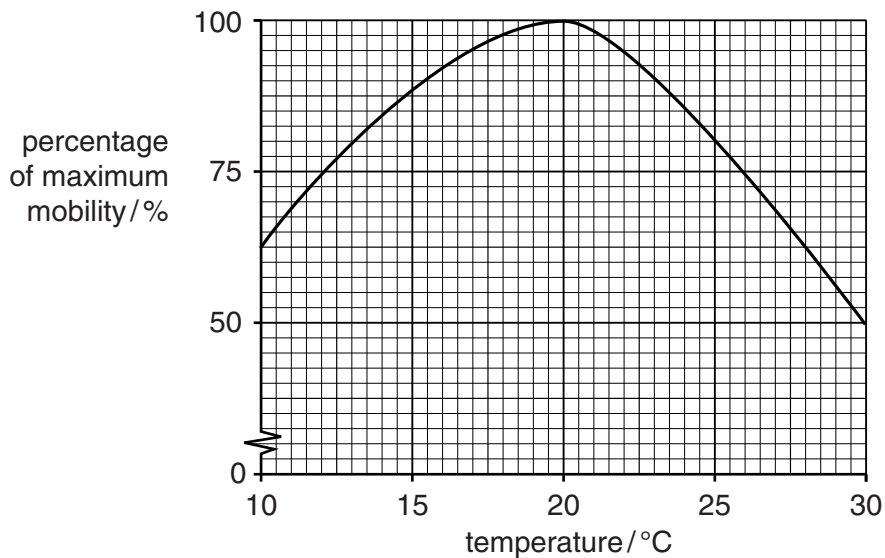

**Fig. 7.2**

(i) State the temperature at which the sperm cells are most mobile.

.....[1]

(ii) Suggest why decreased sperm mobility would reduce a man's fertility.

.....  
 .....[1]

(iii) Human core body temperature is 37°C. Use this information and the information in Fig. 7.2 to explain the advantage of the testes being in the scrotum.

.....  
 .....  
 .....[2]

- 8 (a) Two cars **A** and **B** are left in the hot sun during the day. Car **A** is painted black and car **B** is painted white.

car **A**  
painted black



car **B**  
painted white

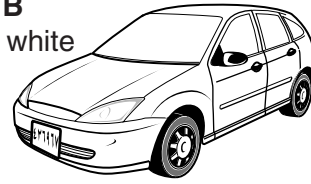

**Fig. 8.1**

Energy from the sun heats both cars.

State the method of energy transfer between the Sun and the Earth.

.....[1]

- (b) Car **A** has two headlights and two rear lights. The lamp inside each light is connected in parallel with each of the other lamps across a 12V battery.

- (i) Complete the circuit diagram below to show how the lamps are connected to the battery.

Include one switch in the circuit which will control the two lamps inside the headlight and a second switch which will control the two lamps inside the rear lights.

Label clearly the lamps for the two headlights and the two rear lights.

12V

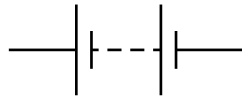

[4]

- (ii) The current passing through one lamp in a headlight is 4.8 A. Show that the resistance of this lamp is  $2.5 \Omega$ .

State the formula that you use and show your working.

formula

working

[2]

- (iii) Two other lamps in the car are connected in series with each other. Each lamp has a resistance of  $14 \Omega$ .

Calculate the combined resistance of the two lamps connected in series.

resistance = .....  $\Omega$  [1]

- (c) Some cars are fitted with proximity detectors to warn the driver when the car is too close to other objects.

These detectors use ultrasound. Fig. 8.2 shows a car fitted with an ultrasound proximity detector.

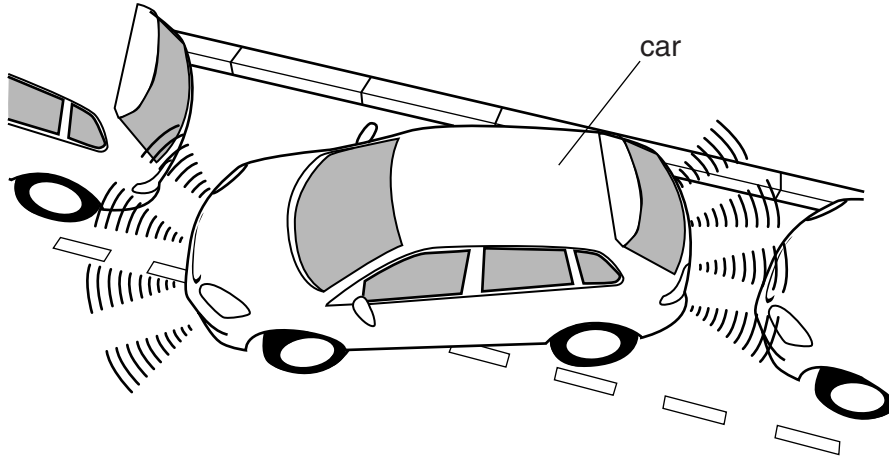

**Fig. 8.2**

- (i) The ultrasound waves used have a frequency of 40 000 Hz. This means that they are usually outside the audible range of a human.

Write down the normal audible human range.

..... Hz to ..... Hz [2]

- (ii) State the meaning of the term *frequency*.

.....  
 ..... [1]

- (iii) An ultrasound wave is emitted from the sensor in the car and the wave, reflected from a nearby object, is received 0.002 s later. The speed of ultrasound waves in air is 34 000 cm/s.

Calculate the distance of the car from the nearby object.

State the formula that you use and show your working.

formula

working

distance = ..... cm [2]

9 Nitrogen is an element in Group V of the Periodic Table.

(a) A nitrogen atom has a proton number of 7 and a nucleon number of 14.

(i) State the number of electrons in a nitrogen atom.

.....[1]

(ii) Describe the composition of the nucleus of this nitrogen atom.

.....  
.....  
.....[2]

(iii) Explain in terms of numbers of protons and electrons why the nitride ion,  $N^{3-}$ , has a negative electrical charge.

.....  
.....[1]

(b) Fig. 9.1 shows apparatus which can be used to make ammonia,  $\text{NH}_3$ .

The piston of gas syringe **A** is pushed in slowly, and the mixture of nitrogen and hydrogen moves through the small pieces of heated iron into gas syringe **B**.

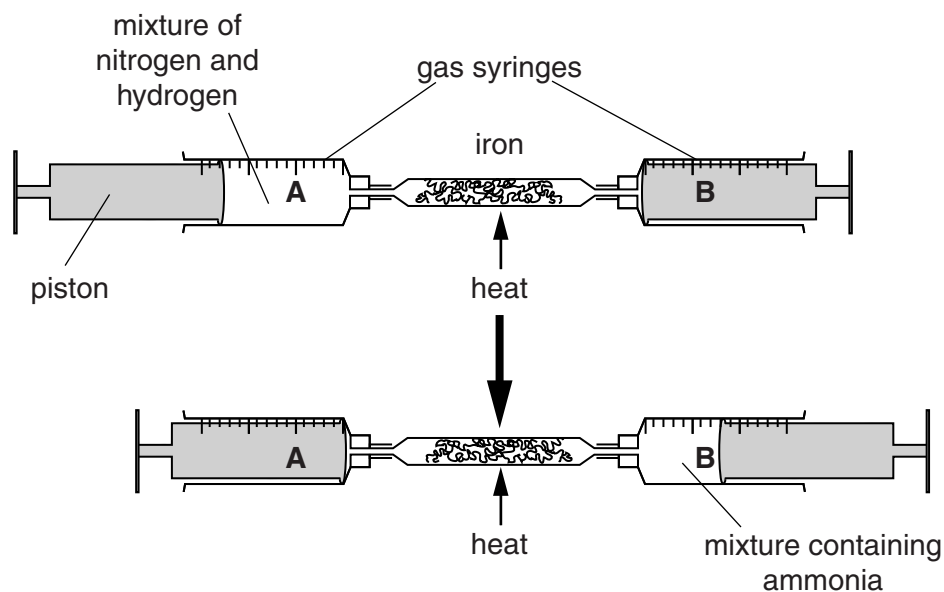

Fig. 9.1

Some nitrogen reacts with hydrogen on the surface of the heated iron.

(i) Construct a **word** equation for the reaction that occurs in the apparatus shown in Fig. 9.1.



[1]

(ii) Describe a **chemical** test used to show that ammonia is produced.

State the result of this test.

test .....

result ..... [2]

(iii) The iron in this reaction acts as a catalyst.

State the meaning of the term *catalyst*.

.....  
 .....  
 ..... [2]

(c) Suggest the name of an acid that reacts with ammonia to produce ammonium sulfate.

..... [1]



10 (a) In many power stations, energy is transferred to turbines to turn generators.

(i) A nuclear power station usually has a greater efficiency than a power station which burns fossil fuels.

Explain the meaning of the term *efficiency*.

.....  
.....[1]

(ii) In a nuclear power station, fission of uranium-235 nuclei takes place.

Describe what happens to the nuclei of uranium-235, in this process.

.....  
.....[1]

(b) In a nuclear power station, technicians work close to radioactive sources.

These sources emit  $\alpha$ -radiation,  $\beta$ -radiation and  $\gamma$ -radiation.

(i) State which of these radiations is part of the electromagnetic spectrum.

.....[1]

(ii) State which of these radiations does **not** have an electric charge.

.....[1]

(iii) Describe **two** effects, harmful to the technicians, from ionising radiation emitted by radioactive sources.

1 .....  
.....

2 .....  
.....[2]

(iv) State **one** way in which these workers could be protected from ionising radiation.

.....  
.....[1]

11 Fig. 11.1 shows part of the gas exchange surface of a leaf.

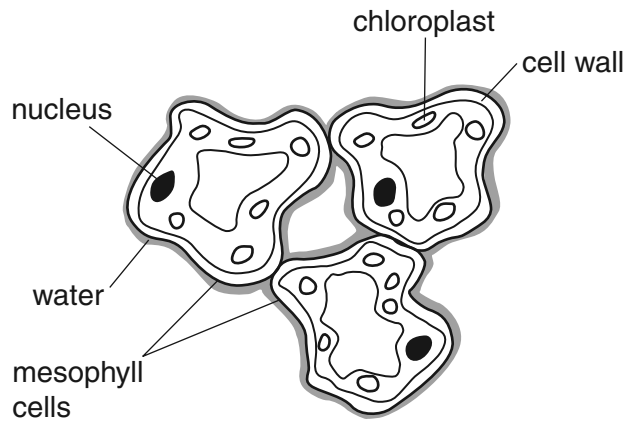

Fig. 11.1

(a) Using the information in Fig. 11.1, state **two** ways in which this surface is adapted for efficient gas exchange.

1 .....

2 ..... [2]

(b) (i) Name the gas that is entering the cells of the leaf from the air during a period of bright sunlight.

..... [1]

(ii) Name the process by which this gas moves into the cells of the leaf.

..... [1]

(c) The mesophyll cells shown in Fig. 11.1 are found in the middle of a leaf.

Name **three** other types of cell that leaves contain.

1 .....

2 .....

3 ..... [3]

12 (a) Fig. 12.1 shows a small piece of potassium being added to water.

The water is coloured green by full-range indicator solution (Universal Indicator).

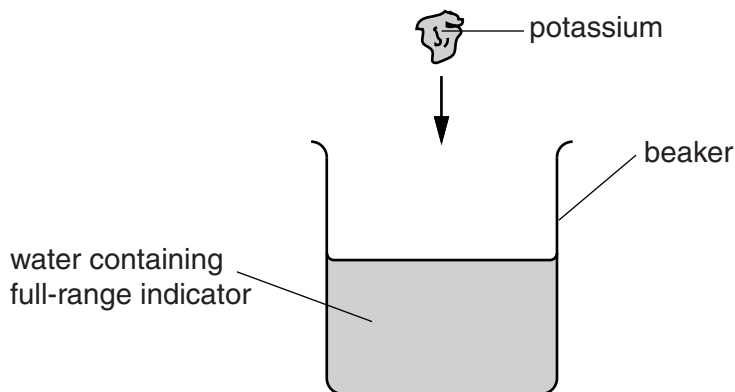

Fig. 12.1

(i) Explain why potassium is an example of an element and water is an example of a compound.

potassium is an element because .....

.....

water is a compound because .....

.....[2]

(ii) State and explain the colour change observed in the beaker when the potassium reacts with the water.

colour change ..... **green** ..... to .....

explanation .....

.....[2]

(iii) During the reaction between potassium and water, the piece of potassium melts.

Explain this observation.

.....

.....[1]

(iv) When lithium is used instead of potassium in the experiment the colour change in (ii) is the same.

Predict **one** observation that will be different.

.....

.....[1]

- (b) Chloramine,  $\text{NH}_2\text{Cl}$ , is a compound that is added to water supplies as one of the processes used in drinking water purification.

Fig. 12.2 shows the structure of a chloramine molecule.

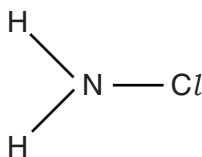

Fig. 12.2

- (i) Predict the type of chemical bonding between the atoms in a chloramine molecule.

Explain your answer.

type of bonding .....

explanation .....

.....[2]

- (ii) Suggest how chloramine helps to purify drinking water supplies.

.....

.....[1]

- (iii) State **one** other process that is used in the purification of drinking water.

.....[1]







## DATA SHEET

### The Periodic Table of the Elements

Group																			
I	II											III	IV	V	VI	VII	0		
											1 <b>H</b> Hydrogen 1						2 <b>He</b> Helium 2		
7 <b>Li</b> Lithium 3	9 <b>Be</b> Beryllium 4											11 <b>B</b> Boron 5	12 <b>C</b> Carbon 6	14 <b>N</b> Nitrogen 7	16 <b>O</b> Oxygen 8	19 <b>F</b> Fluorine 9	20 <b>Ne</b> Neon 10		
23 <b>Na</b> Sodium 11	24 <b>Mg</b> Magnesium 12											27 <b>Al</b> Aluminium 13	28 <b>Si</b> Silicon 14	31 <b>P</b> Phosphorus 15	32 <b>S</b> Sulfur 16	35.5 <b>Cl</b> Chlorine 17	40 <b>Ar</b> Argon 18		
39 <b>K</b> Potassium 19	40 <b>Ca</b> Calcium 20	45 <b>Sc</b> Scandium 21	48 <b>Ti</b> Titanium 22	51 <b>V</b> Vanadium 23	52 <b>Cr</b> Chromium 24	55 <b>Mn</b> Manganese 25	56 <b>Fe</b> Iron 26	59 <b>Co</b> Cobalt 27	59 <b>Ni</b> Nickel 28	64 <b>Cu</b> Copper 29	65 <b>Zn</b> Zinc 30	70 <b>Ga</b> Gallium 31	73 <b>Ge</b> Germanium 32	75 <b>As</b> Arsenic 33	79 <b>Se</b> Selenium 34	80 <b>Br</b> Bromine 35	84 <b>Kr</b> Krypton 36		
85 <b>Rb</b> Rubidium 37	88 <b>Sr</b> Strontium 38	89 <b>Y</b> Yttrium 39	91 <b>Zr</b> Zirconium 40	93 <b>Nb</b> Niobium 41	96 <b>Mo</b> Molybdenum 42	<b>Tc</b> Technetium 43	101 <b>Ru</b> Ruthenium 44	103 <b>Rh</b> Rhodium 45	106 <b>Pd</b> Palladium 46	108 <b>Ag</b> Silver 47	112 <b>Cd</b> Cadmium 48	115 <b>In</b> Indium 49	119 <b>Sn</b> Tin 50	122 <b>Sb</b> Antimony 51	128 <b>Te</b> Tellurium 52	127 <b>I</b> Iodine 53	131 <b>Xe</b> Xenon 54		
133 <b>Cs</b> Caesium 55	137 <b>Ba</b> Barium 56	139 <b>La</b> Lanthanum 57 *	178 <b>Hf</b> Hafnium 72	181 <b>Ta</b> Tantalum 73	184 <b>W</b> Tungsten 74	186 <b>Re</b> Rhenium 75	190 <b>Os</b> Osmium 76	192 <b>Ir</b> Iridium 77	195 <b>Pt</b> Platinum 78	197 <b>Au</b> Gold 79	201 <b>Hg</b> Mercury 80	204 <b>Tl</b> Thallium 81	207 <b>Pb</b> Lead 82	209 <b>Bi</b> Bismuth 83	209 <b>Po</b> Polonium 84	210 <b>At</b> Astatine 85	222 <b>Rn</b> Radon 86		
223 <b>Fr</b> Francium 87	226 <b>Ra</b> Radium 88	227 <b>Ac</b> Actinium 89 †																	

140 <b>Ce</b> Cerium 58	141 <b>Pr</b> Praseodymium 59	144 <b>Nd</b> Neodymium 60	147 <b>Pm</b> Promethium 61	150 <b>Sm</b> Samarium 62	152 <b>Eu</b> Europium 63	157 <b>Gd</b> Gadolinium 64	159 <b>Tb</b> Terbium 65	162 <b>Dy</b> Dysprosium 66	165 <b>Ho</b> Holmium 67	167 <b>Er</b> Erbium 68	169 <b>Tm</b> Thulium 69	173 <b>Yb</b> Ytterbium 70	175 <b>Lu</b> Lutetium 71
232 <b>Th</b> Thorium 90	231 <b>Pa</b> Protactinium 91	238 <b>U</b> Uranium 92	237 <b>Np</b> Neptunium 93	244 <b>Pu</b> Plutonium 94	243 <b>Am</b> Americium 95	247 <b>Cm</b> Curium 96	247 <b>Bk</b> Berkelium 97	251 <b>Cf</b> Californium 98	252 <b>Es</b> Einsteinium 99	257 <b>Fm</b> Fermium 100	258 <b>Md</b> Mendelevium 101	259 <b>No</b> Nobelium 102	260 <b>Lr</b> Lawrencium 103

\* 58–71 Lanthanoid series

† 90–103 Actinoid series

Key

a	a = relative atomic mass
<b>X</b>	X = atomic symbol
b	b = atomic (proton) number

The volume of one mole of any gas is 24 dm<sup>3</sup> at room temperature and pressure (r.t.p.).