



**Cambridge International Examinations**  
Cambridge International General Certificate of Secondary Education

CANDIDATE  
NAME

--

CENTRE  
NUMBER

--	--	--	--	--

CANDIDATE  
NUMBER

--	--	--	--



**CO-ORDINATED SCIENCES**

**0654/32**

Paper 3 (Extended)

**October/November 2015**

**2 hours**

Candidates answer on the Question Paper.

No Additional Materials are required.

**READ THESE INSTRUCTIONS FIRST**

Write your Centre number, candidate number and name on all the work you hand in.

Write in dark blue or black pen.

You may use an HB pencil for any diagrams, graphs, tables or rough working.

Do not use staples, paper clips, glue or correction fluid.

**DO NOT WRITE IN ANY BARCODES.**

Answer **all** questions.

Electronic calculators may be used.

You may lose marks if you do not show your working or if you do not use appropriate units.

A copy of the Periodic Table is printed on page 32.

At the end of the examination, fasten all your work securely together.

The number of marks is given in brackets [ ] at the end of each question or part question.

This document consists of **31** printed pages and **1** blank page.

1 Fig. 1.1 shows a compost bin. Gardeners use these bins to produce compost which is a useful fertiliser for plants.

They put weeds, dead leaves and other garden waste into the bin. Over time, these break down to produce the fertiliser.

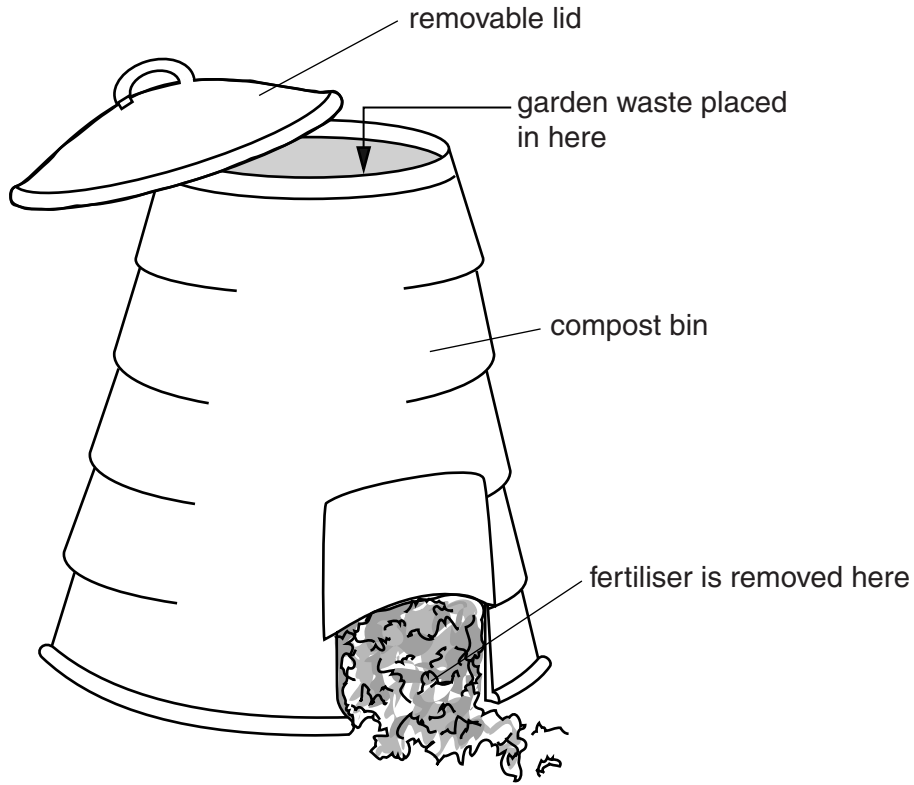

Fig. 1.1

- (a) (i) Name the type of organism that breaks down the garden waste into fertiliser for plants.  
.....[1]
- (ii) Name **two** substances in the fertiliser that plants can use.
- 1 .....
- 2 .....[2]

(b) The organisms that break down the garden waste are respiring aerobically and anaerobically.

(i) Name **two** substances that they might produce in anaerobic respiration.

1 .....

2 .....[2]

(ii) Suggest **two** things that a gardener could do to help the organisms in the compost bin to respire quickly and aerobically.

1 .....

2 .....[2]

(c) On farms, crop plants must be given fertiliser if the crop is to grow well year after year. However, plants in natural ecosystems can grow each year without the need for any fertiliser.

Explain why natural ecosystems do not need fertiliser.

.....

.....[1]

- 2 The reactivity series shows metallic elements in order of their reactivities. This series also contains hydrogen because it has some chemical properties similar to metals.

(a) Fig. 2.1 shows apparatus and materials a student uses to investigate the reactivity of an unknown metal **J**.

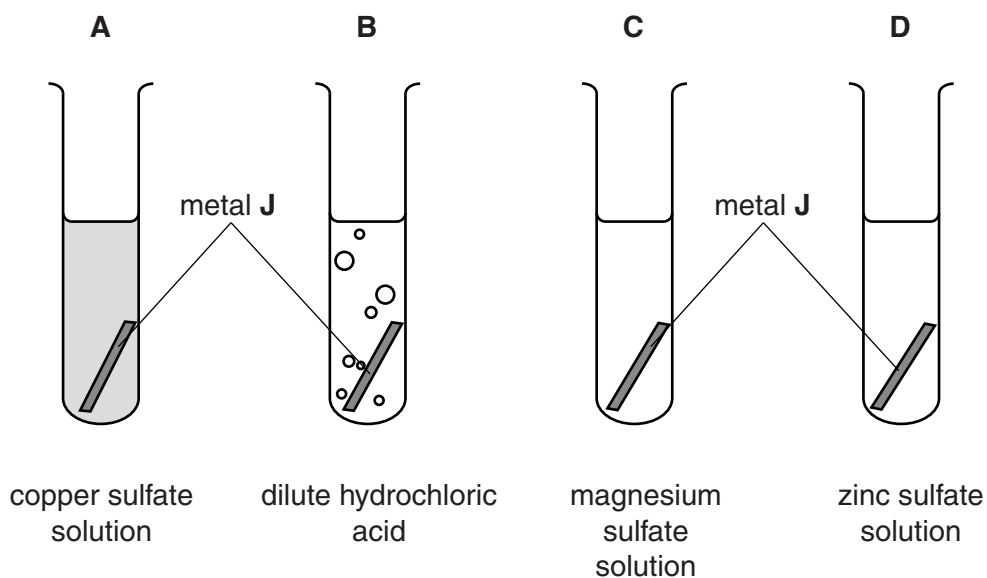

Fig. 2.1

She places a small piece of metal **J** into each of four test-tubes **A**, **B**, **C** and **D**. Table 2.1 shows her observations.

Table 2.1

test-tube	test-tube contents	observation with metal <b>J</b>
<b>A</b>	copper sulfate solution	orange-brown solid forms on metal <b>J</b>
<b>B</b>	dilute hydrochloric acid	gas given off slowly
<b>C</b>	magnesium sulfate solution	no reaction
<b>D</b>	zinc sulfate solution	no reaction

- (i) Use the results in Table 2.1 **and** your knowledge of the reactivity series to place the five elements, copper, hydrogen, **J**, magnesium and zinc into order of reactivity.

1 ..... (most reactive element)

2 .....

3 .....

4 .....

5 ..... (least reactive element)

[2]

- (ii) Reduction and oxidation (redox) are terms used to describe chemical reactions that involve the transfer of electrons between particles.

Using the ideas of electron transfer, atoms and ions, deduce which particles are **reduced** during the reaction in test-tube **A** as shown in Table 2.1.

particles that are reduced .....

explanation .....

.....

.....

.....[3]

- (b) Fig. 2.2 shows a diamond set into a ring made of an alloy of gold.

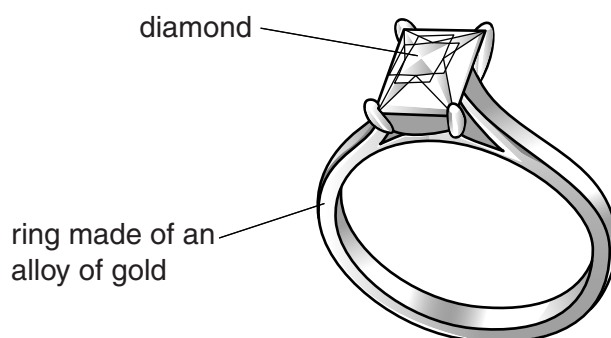

**Fig. 2.2**

- (i) The alloy of gold contains many gold atoms with fewer atoms of a different metal.

In the box below, draw a sketch to show the arrangement of the atoms in this alloy. Your diagram should include at least fifteen gold atoms.

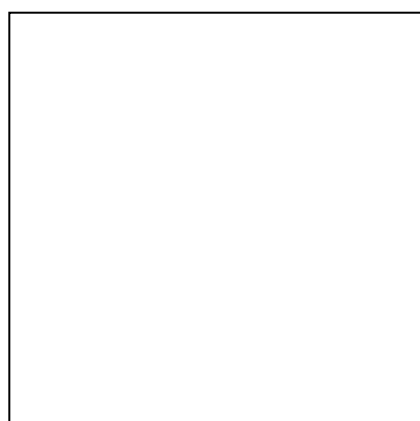

key



atom of gold



atom of a different metal

[2]

- (ii) Diamond is made up of carbon atoms. The mass of a diamond can be measured in units known as carats.

A diamond of one carat has a mass of 0.2 grams.

Calculate the number of moles of carbon that are contained in a diamond of 186 carats.

Show your working.

number of moles ..... [2]

- 3 (a) Fig. 3.1 shows a speed/time graph for a train.

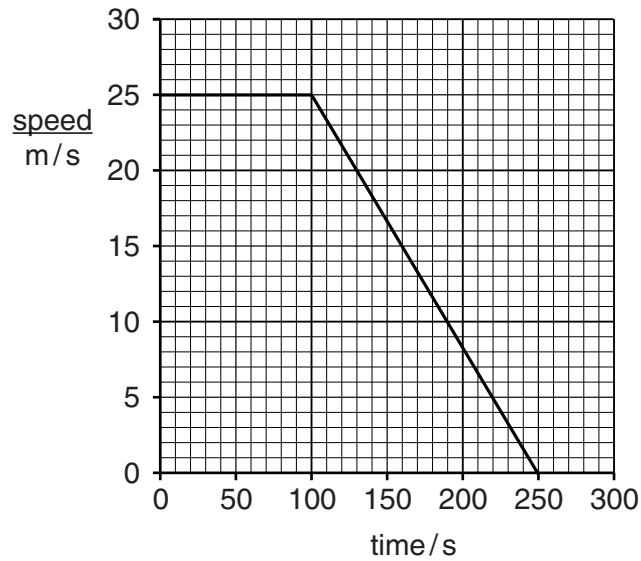

**Fig. 3.1**

- (i) Calculate the distance travelled by the train between 0s and 250s. State the unit.

Show your working.

distance = ..... unit ..... [3]

- (ii) The mass of the train is 500 000 kg.

Calculate the kinetic energy of the train in kilojoules, when it is travelling at 20 m/s.

State the formula that you use and show your working.

formula

working

kinetic energy = ..... kJ [2]

(b) The track for the train is composed of steel rails.

Steel has a density of  $7.80 \text{ g/cm}^3$  at  $20^\circ\text{C}$ .

(i) State how the density of steel changes when the temperature rises to  $35^\circ\text{C}$ . Explain why this happens in terms of particles.

.....  
.....  
.....  
.....  
.....[3]

(ii) The steel rails are made from steel blocks. Each block is a cube with sides of 50 cm.

Calculate the mass of one of these steel blocks in kilograms when the temperature is  $20^\circ\text{C}$ .

Show your working.

mass = ..... kg [3]



4 Fig. 4.1 shows a liquid fossil fuel being extracted from rock layers beneath the sea bed.

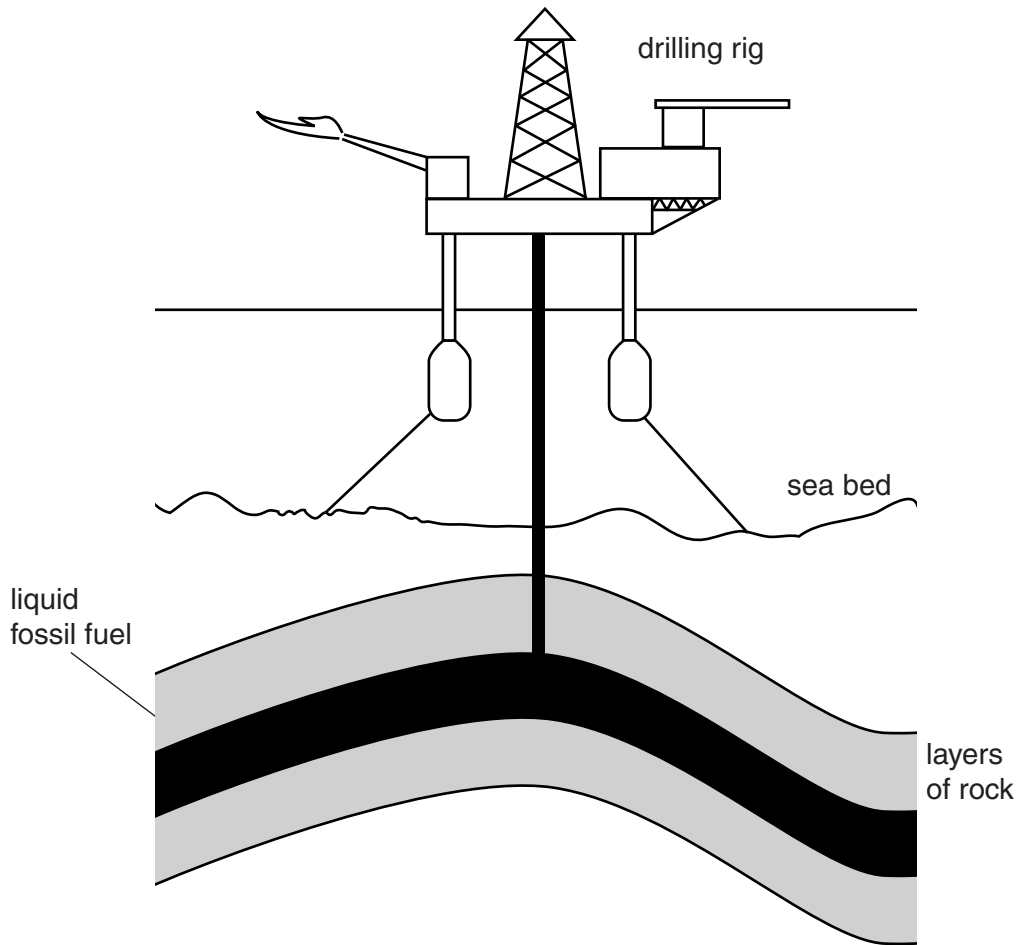

**Fig. 4.1**

**(a)** Name the fossil fuel being extracted.

.....[1]

(b) The material extracted from the rock is a mixture of hydrocarbons.

Fractional distillation is the process used to separate simpler, more useful mixtures from the fossil fuel.

Fig. 4.2 shows a simplified diagram of industrial fractional distillation.

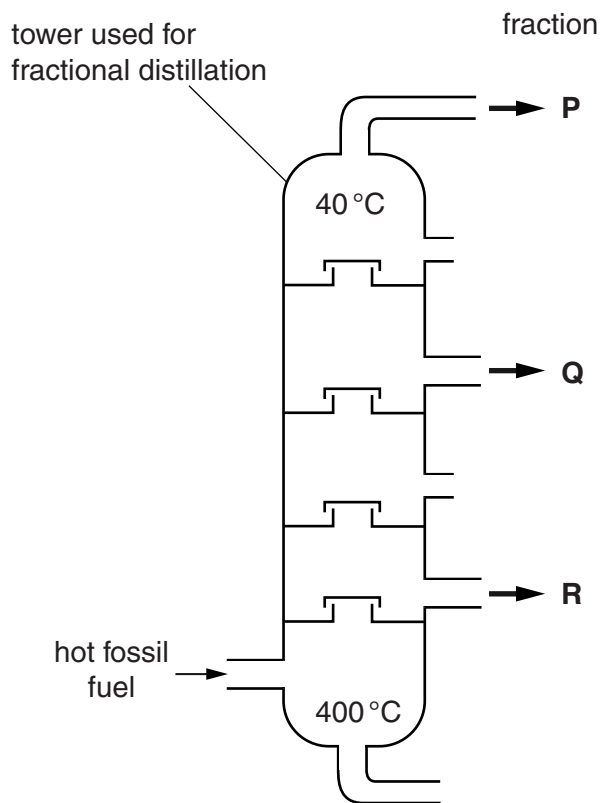

**Fig. 4.2**

Fig. 4.2 shows three fractions, **P**, **Q** and **R**, collecting at different heights in the tower.

Explain in terms of boiling temperatures and sizes of molecules why different fractions collect at different heights in the tower.

.....

.....

.....

.....

..... [3]

(c) Fig. 4.3 shows a simplified diagram of another industrial process involving hydrocarbons.

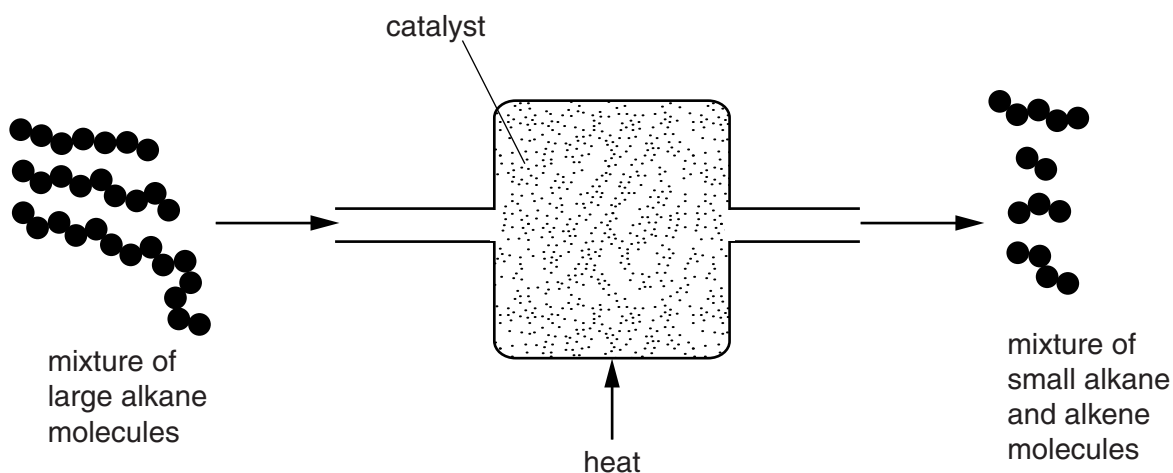

**Fig. 4.3**

(i) Name the process shown in Fig. 4.3.  
 .....[1]

(ii) Describe a chemical test for an unsaturated hydrocarbon. State the result.  
 test .....  
 .....  
 result .....  
 .....[2]

(iii) Suggest how the test you have described in (c)(ii) could be used to show that the process shown in Fig. 4.3 produces alkenes.  
 .....  
 .....  
 .....[2]

5 (a) Define the term *nutrition*.

.....  
.....  
.....[2]

(b) (i) State what is meant by *malnutrition*.

.....  
.....[1]

(ii) Describe how malnutrition may result in obesity.

.....  
.....[1]

(c) Fig. 5.1 shows how the percentage of overweight children in a European country changed between 1950 and 2010.

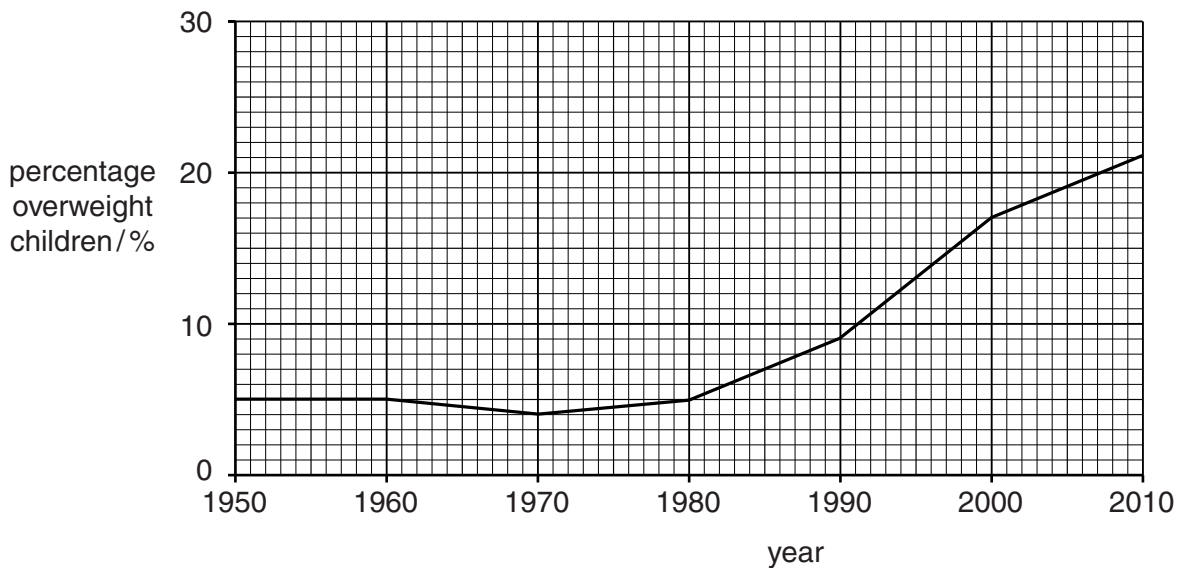

Fig. 5.1

(i) Describe how the percentage of overweight children changed between 1950 and 2010.

.....  
.....  
.....  
.....[2]

(ii) Suggest a reason for this change.

.....  
.....[1]

(iii) State **two** health problems that may occur in later life if a person is overweight.

1 .....  
2 .....[2]

(d) A person's health will suffer if they do not get enough essential vitamins in their diet, such as vitamin D.

(i) State the function of vitamin D in the body.

.....  
.....[1]

(ii) Name **one** food that is a good source of vitamin D.

.....[1]

(iii) Describe the effects on the body of a shortage of vitamin D.

.....  
.....  
.....[2]

6 (a) Fig. 6.1 shows a cyclist approaching a corner.

The cyclist is unable to see car C approaching from around the corner unless he uses the mirror positioned at X.

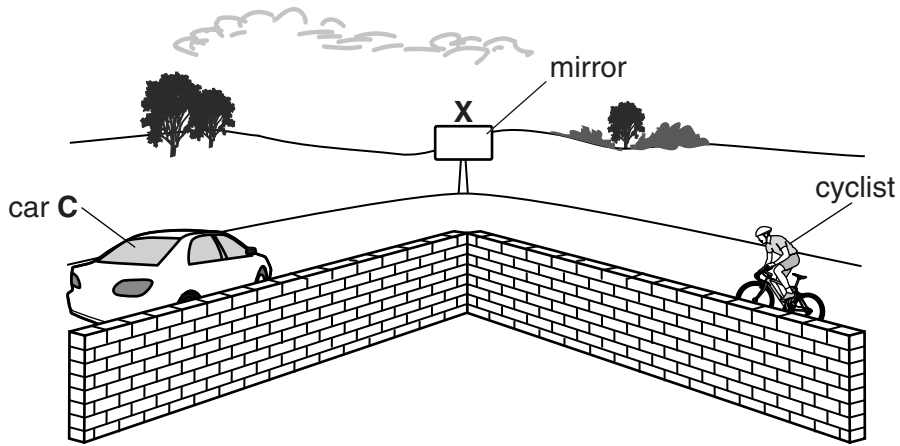

Fig. 6.1

Fig. 6.2 shows the same situation viewed from above.

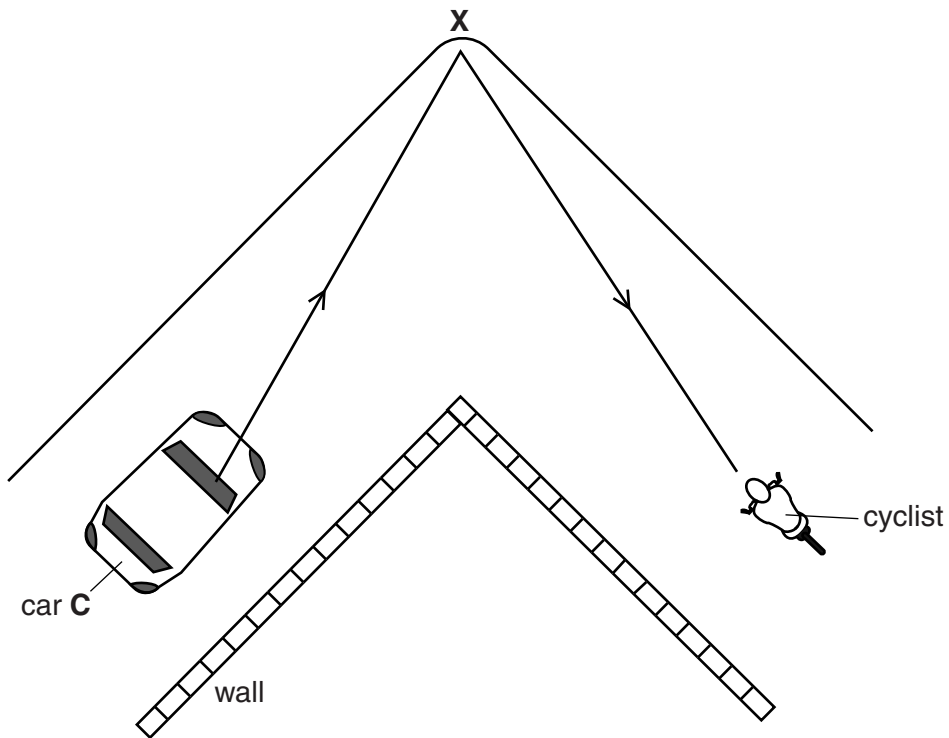

Fig. 6.2

A ray of light is drawn from the car to the cyclist reflecting at point X.

On Fig. 6.2 draw the mirror at X at the correct angle.

[1]

- (b) A reflector on the back of the bicycle is made from many small glass prisms, one of which is shown in Fig. 6.3.

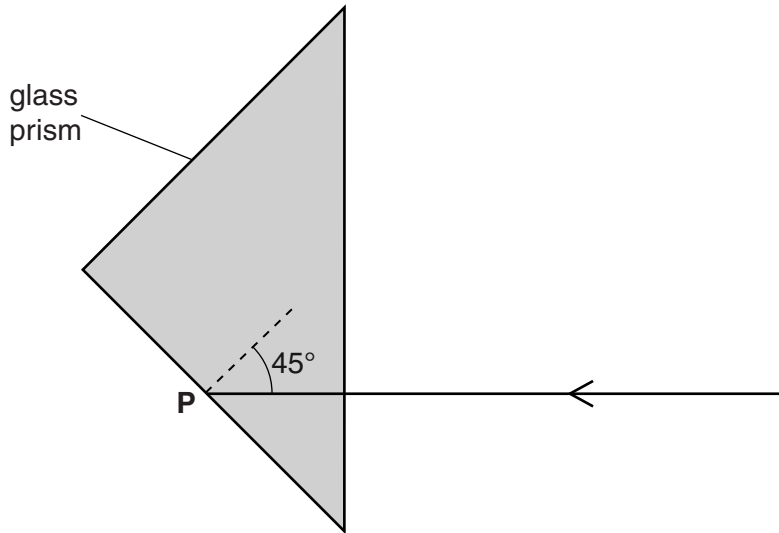

Fig. 6.3

A ray of light is incident on the back surface of the prism at point P at an angle of 45°.

The critical angle for glass is 42°.

Explain why light does not leave the prism at point P.

.....  
 .....[1]

- (c) Bicycle wheels can be made from steel or an aluminium alloy.

Suggest a simple way of testing whether a wheel is made from steel or aluminium alloy.

.....  
 .....[1]

(d) The cyclist has a puncture which he repairs. He pumps up the flat tyre.

Each pump stroke takes  $90 \text{ cm}^3$  of air at a pressure of  $1 \times 10^5 \text{ Pa}$  and pushes it into the tyre.

When fully inflated, the tyre contains  $1600 \text{ cm}^3$  of air at room temperature and at a pressure of  $2 \times 10^5 \text{ Pa}$ . Assume that the temperature of the air does not change.

(i) Show that the volume of air from the pump required to inflate the tyre fully is  $3200 \text{ cm}^3$ .

State the formula that you use and show your working.

formula

working

[2]

(ii) Calculate the number of pump strokes needed to pump in  $3200 \text{ cm}^3$  of air.

Show your working.

number of pump strokes = ..... [1]



7 Fig. 7.1 shows a sperm cell. Sperm cells are male gametes.



Fig. 7.1

(a) On Fig. 7.1, label the nucleus and the cell membrane of the sperm cell. [2]

(b) Male gametes are mobile but female gametes are not.

State **two** other differences between male and female gametes.

1 .....

2 ..... [2]

(c) Fig. 7.2 shows how the mobility of sperm cells varies with temperature.

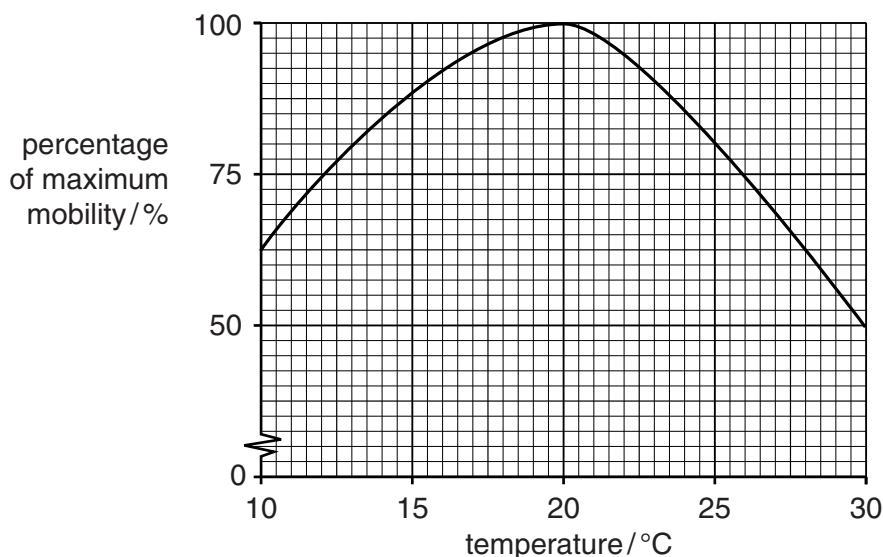

Fig. 7.2

(i) State the temperature at which the sperm cells are most mobile.  
 ..... [1]

(ii) Energy for the movement of the sperm comes from respiration.  
 Suggest why the sperm cells are less mobile at 10 °C than at 15 °C.  
 .....  
 ..... [1]

(iii) Use the information in Fig. 7.2 to predict the mobility of the sperm cells at 5 °C.  
 ..... [1]

(d) Human core body temperature is 37°C. Use this information and the information in Fig. 7.2 to explain

(i) what would be the effect on sperm mobility if the testes were located inside the main body cavity,

.....  
.....[1]

(ii) the advantage of the testes being located in the scrotum,

.....  
.....[1]

(iii) what would be the effect of increased sperm temperature on a man's fertility.

.....  
.....[1]

- 8 (a) Two cars **A** and **B** are left in the hot sun during the day. Car **A** is painted black and car **B** is painted white.

car **A**  
painted black



car **B**  
painted white



**Fig. 8.1**

Energy from the sun heats both cars.

- (i) State the method of energy transfer between the Sun and the Earth.

.....[1]

- (ii) Suggest which car will have the greater temperature change. Explain your answer.

.....  
.....[1]

- (b) Car **A** has two headlights. The lamp inside each headlight is connected in parallel with the other across a 12V battery.

- (i) The current passing through each of the lamps is 4.8 A. Show that the resistance of each lamp is  $2.5\ \Omega$ .

State the formula that you use and show your working.

formula

working

[2]

- (ii) Calculate the combined resistance of the two lamps, each of resistance  $2.5\ \Omega$  connected in parallel.

State the formula that you use and show your working.

formula

working

resistance = .....  $\Omega$  [2]

- (c) Some cars are fitted with proximity detectors to warn the driver when the car is too close to other objects.

These detectors use ultrasound. Fig. 8.2 shows a car fitted with an ultrasound proximity detector.

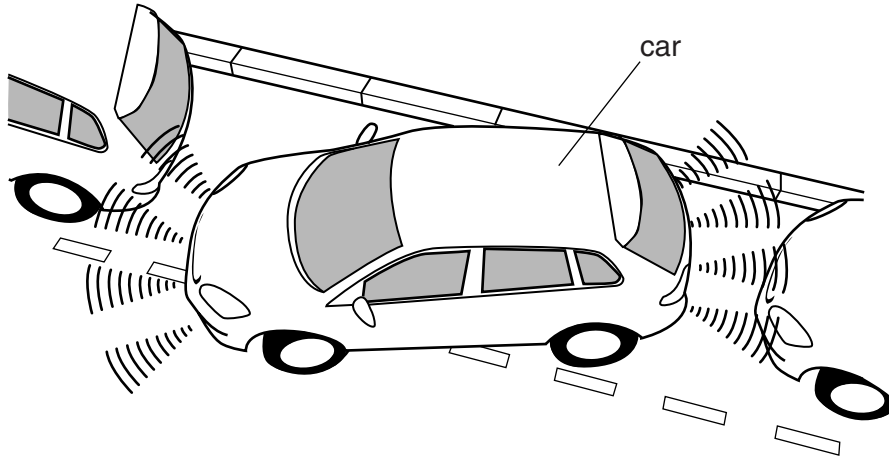

**Fig. 8.2**

- (i) The ultrasound waves used have a frequency of 40 000 Hz. This means that they are usually outside the audible range of a human.

Write down the normal audible human range.

..... Hz to ..... Hz [1]

- (ii) An ultrasound wave is emitted from the sensor in the car and the wave, reflected from a nearby object, is received 0.002 s later. The speed of ultrasound waves in air is 34 000 cm/s.

Calculate the distance of the car from the nearby object.

State the formula that you use and show your working.

formula

working

distance = ..... cm [2]

- (iii) Use information from (c)(i) and (ii) to calculate the wavelength of the ultrasound waves in metres.

State the formula that you use and show your working.

formula

working

wavelength = ..... m [2]

- (iv) The ultrasound waves pass through the air as a series of compressions (C) and rarefactions (R).

Fig. 8.3 shows the positions of the compressions and rarefactions as the ultrasound wave passes through the air.



Fig. 8.3

Suggest how and explain why the positions of the compressions and rarefactions change when the frequency of the ultrasound decreases.

.....

.....

..... [2]

9 Nitrogen is an element in Group V of the Periodic Table.

(a) (i) State the electron configuration of a nitrogen atom.

.....[1]

(ii) Explain why the nitride ion,  $\text{N}^{3-}$ , has an electrical charge of 3–.

.....

.....

.....[2]

(iii) Magnesium nitride is an ionic compound that forms when magnesium burns in air.

The symbol and charge of a magnesium ion is  $\text{Mg}^{2+}$ .

Deduce the chemical formula of magnesium nitride.

Show your working.

chemical formula = ..... [2]

(b) Fig. 9.1 shows apparatus which can be used to make ammonia,  $\text{NH}_3$ .

The piston of gas syringe **A** is pushed in slowly, and the mixture of nitrogen,  $\text{N}_2$ , and hydrogen,  $\text{H}_2$ , moves through the small pieces of heated iron into gas syringe **B**.

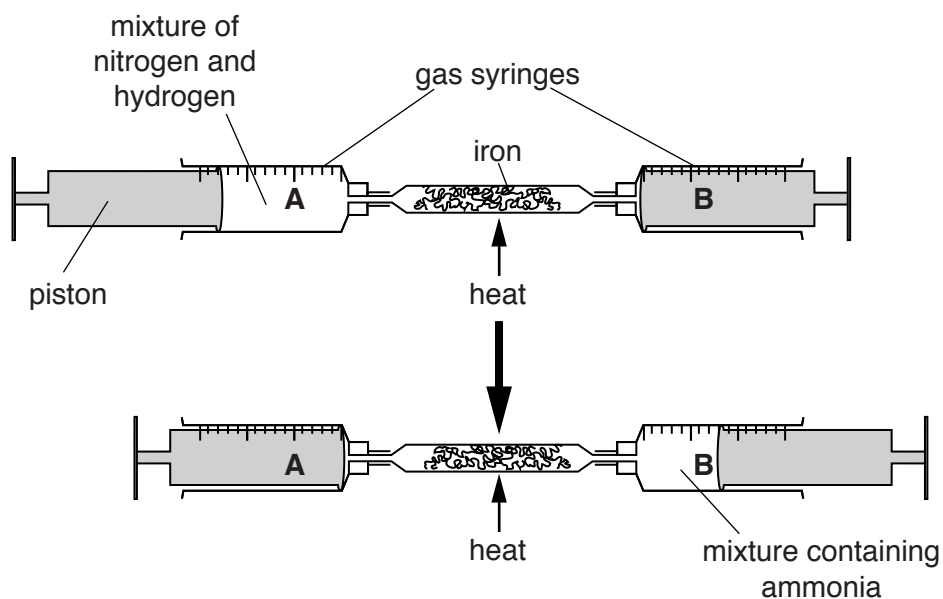

Fig. 9.1

Some nitrogen reacts with hydrogen on the surface of the heated iron.

(i) Construct a balanced equation for the reaction between nitrogen and hydrogen.

.....[1]

(ii) Describe a **chemical** test used to show that ammonia is produced.

State the result of this test.

test .....

result .....

.....[2]

(iii) The iron in this reaction acts as a catalyst.

Suggest in terms of molecular collisions why the iron is in the form of many small pieces.

.....

.....

.....

.....[2]

10 (a) (i) A nuclear power station generates 800 MW of power from a power input of 2400 MW.

Calculate the efficiency of the power station.

State the formula that you use and show your working.

formula

working

efficiency = ..... % [2]

(ii) In a nuclear power station, fission of uranium-235 nuclei takes place to release energy.

A different nuclear process takes place in the Sun to release energy from hydrogen nuclei.

Describe what happens to the hydrogen nuclei in the process that takes place in the Sun.

.....  
.....[1]

(b) In a nuclear power station, technicians work close to radioactive sources.

These sources emit  $\alpha$ -radiation,  $\beta$ -radiation and  $\gamma$ -radiation.

(i) State which of these radiations is part of the electromagnetic spectrum.

.....[1]

(ii) State which of these radiations is not deflected by an electric field.

Explain your answer.

radiation .....

explanation .....  
.....[1]



- (c) Large generators are used in power stations to produce electricity. The voltage needs to be increased before transmission.

This is done using a transformer, which increases the voltage from 25 000V to 400 000V.

- (i) Explain why high voltages are used for the transmission of electric power.

.....  
.....  
.....[2]

- (ii) Fig. 10.1 shows the simplified structure of a transformer.

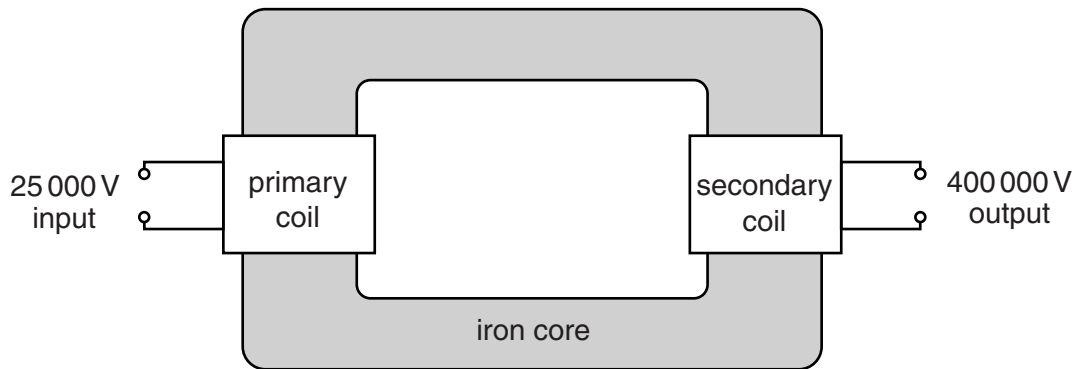

Fig. 10.1

Describe how the transformer works to change the voltage.

.....  
.....  
.....  
.....  
.....  
.....[3]

11 Fig. 11.1 shows parts of the gas exchange surfaces of a leaf and a lung.

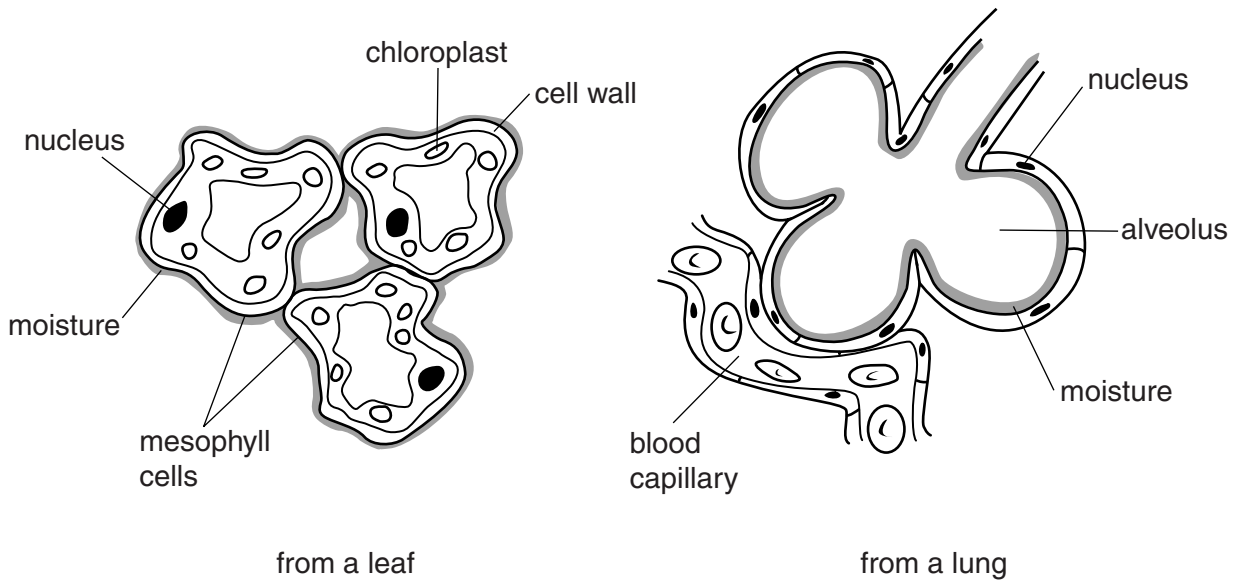

Fig. 11.1

(a) (i) Using the information in Fig. 11.1, state **two** ways in which **both** of these surfaces are adapted for efficient gas exchange.

- 1 .....
- 2 ..... [2]

(ii) Using the information in Fig. 11.1, state **one** feature of the gas exchange surface of the alveolus which is **not** found in the leaf.

.....  
 ..... [1]

(b) For the leaf,

(i) name the gas that is entering the cells from the air during a period of bright sunlight,  
 ..... [1]

(ii) name the process by which this gas moves into the cells.  
 ..... [1]

(c) Emphysema is a disease caused by smoking.

Fig. 11.2 shows how the alveoli of the lungs change in emphysema.

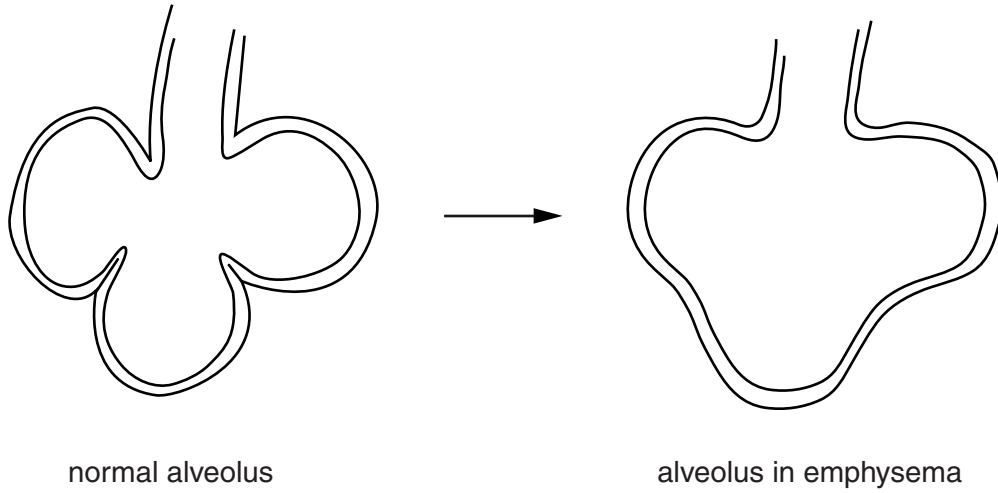

**Fig. 11.2**

(i) Describe and explain the effect of this change on the functioning of the lungs.

.....

.....

..... [2]

(ii) State **two** other harmful effects of smoking on the gas exchange system.

1 .....

2 ..... [2]

- 12 (a) Fig. 12.1 shows a small piece of potassium being added to water containing full-range indicator solution (Universal Indicator).

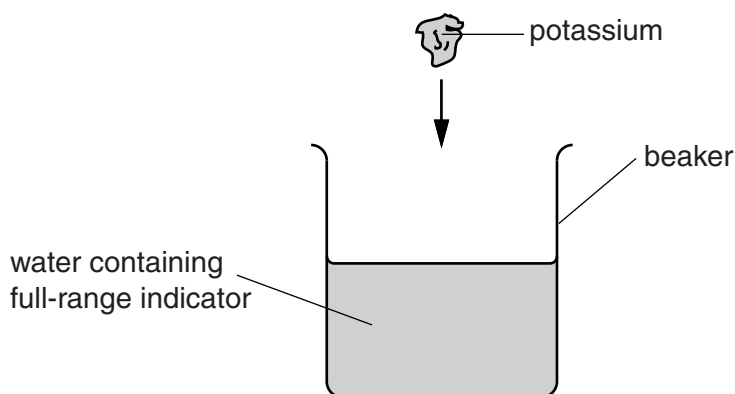
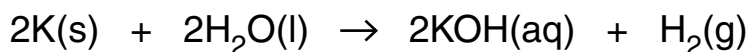

Fig. 12.1

- (i) The balanced chemical equation for the reaction between potassium and water is shown below.



From the four substances shown in the equation select **one** example of an element and **one** example of a compound.

Explain your answers.

element .....

explanation .....

.....

compound .....

explanation .....

.....

[2]

- (ii) Explain why the equation in (a)(i) is described as balanced.

.....

.....[1]

(iii) State the meaning of the state symbols (l) and (aq).

state symbol (l) .....

.....

state symbol (aq) .....

..... [2]

(iv) When potassium reacts with water, the colour of the full range indicator changes.

Describe and explain this change.

.....

.....

..... [2]

(v) During the reaction between potassium and water, the piece of potassium melts and a lilac-coloured flame appears.

Explain these two observations.

.....

.....

.....

..... [2]

(b) Chloramine,  $\text{NH}_2\text{Cl}$ , is a compound that is added to water to kill harmful microorganisms.

Fig. 12.2 shows the outer shell electrons in one molecule of chloramine.

key

● electron

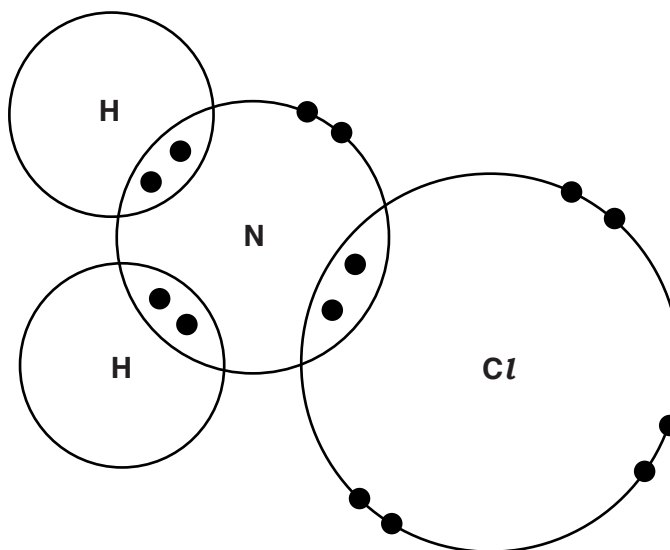

Fig. 12.2

- (i) On Fig. 12.2, draw a label line to a single covalent bond. Label the bond using the letter **S**. [1]
- (ii) Explain the arrangement of electrons shown in Fig. 12.2.

.....

.....

..... [2]



## DATA SHEET

### The Periodic Table of the Elements

Group																			
I	II											III	IV	V	VI	VII	0		
											1 <b>H</b> Hydrogen 1						2 <b>He</b> Helium 2		
7 <b>Li</b> Lithium 3	9 <b>Be</b> Beryllium 4											11 <b>B</b> Boron 5	12 <b>C</b> Carbon 6	14 <b>N</b> Nitrogen 7	16 <b>O</b> Oxygen 8	19 <b>F</b> Fluorine 9	20 <b>Ne</b> Neon 10		
23 <b>Na</b> Sodium 11	24 <b>Mg</b> Magnesium 12											27 <b>Al</b> Aluminium 13	28 <b>Si</b> Silicon 14	31 <b>P</b> Phosphorus 15	32 <b>S</b> Sulfur 16	35.5 <b>Cl</b> Chlorine 17	40 <b>Ar</b> Argon 18		
39 <b>K</b> Potassium 19	40 <b>Ca</b> Calcium 20	45 <b>Sc</b> Scandium 21	48 <b>Ti</b> Titanium 22	51 <b>V</b> Vanadium 23	52 <b>Cr</b> Chromium 24	55 <b>Mn</b> Manganese 25	56 <b>Fe</b> Iron 26	59 <b>Co</b> Cobalt 27	59 <b>Ni</b> Nickel 28	64 <b>Cu</b> Copper 29	65 <b>Zn</b> Zinc 30	70 <b>Ga</b> Gallium 31	73 <b>Ge</b> Germanium 32	75 <b>As</b> Arsenic 33	79 <b>Se</b> Selenium 34	80 <b>Br</b> Bromine 35	84 <b>Kr</b> Krypton 36		
85 <b>Rb</b> Rubidium 37	88 <b>Sr</b> Strontium 38	89 <b>Y</b> Yttrium 39	91 <b>Zr</b> Zirconium 40	93 <b>Nb</b> Niobium 41	96 <b>Mo</b> Molybdenum 42	<b>Tc</b> Technetium 43	101 <b>Ru</b> Ruthenium 44	103 <b>Rh</b> Rhodium 45	106 <b>Pd</b> Palladium 46	108 <b>Ag</b> Silver 47	112 <b>Cd</b> Cadmium 48	115 <b>In</b> Indium 49	119 <b>Sn</b> Tin 50	122 <b>Sb</b> Antimony 51	128 <b>Te</b> Tellurium 52	127 <b>I</b> Iodine 53	131 <b>Xe</b> Xenon 54		
133 <b>Cs</b> Caesium 55	137 <b>Ba</b> Barium 56	139 <b>La</b> Lanthanum 57 *	178 <b>Hf</b> Hafnium 72	181 <b>Ta</b> Tantalum 73	184 <b>W</b> Tungsten 74	186 <b>Re</b> Rhenium 75	190 <b>Os</b> Osmium 76	192 <b>Ir</b> Iridium 77	195 <b>Pt</b> Platinum 78	197 <b>Au</b> Gold 79	201 <b>Hg</b> Mercury 80	204 <b>Tl</b> Thallium 81	207 <b>Pb</b> Lead 82	209 <b>Bi</b> Bismuth 83	209 <b>Po</b> Polonium 84	210 <b>At</b> Astatine 85	222 <b>Rn</b> Radon 86		
223 <b>Fr</b> Francium 87	226 <b>Ra</b> Radium 88	227 <b>Ac</b> Actinium 89 †																	

140 <b>Ce</b> Cerium 58	141 <b>Pr</b> Praseodymium 59	144 <b>Nd</b> Neodymium 60	147 <b>Pm</b> Promethium 61	150 <b>Sm</b> Samarium 62	152 <b>Eu</b> Europium 63	157 <b>Gd</b> Gadolinium 64	159 <b>Tb</b> Terbium 65	162 <b>Dy</b> Dysprosium 66	165 <b>Ho</b> Holmium 67	167 <b>Er</b> Erbium 68	169 <b>Tm</b> Thulium 69	173 <b>Yb</b> Ytterbium 70	175 <b>Lu</b> Lutetium 71
232 <b>Th</b> Thorium 90	231 <b>Pa</b> Protactinium 91	238 <b>U</b> Uranium 92	237 <b>Np</b> Neptunium 93	244 <b>Pu</b> Plutonium 94	243 <b>Am</b> Americium 95	247 <b>Cm</b> Curium 96	247 <b>Bk</b> Berkelium 97	251 <b>Cf</b> Californium 98	252 <b>Es</b> Einsteinium 99	257 <b>Fm</b> Fermium 100	258 <b>Md</b> Mendelevium 101	259 <b>No</b> Nobelium 102	260 <b>Lr</b> Lawrencium 103

\* 58–71 Lanthanoid series

† 90–103 Actinoid series

Key

a	a = relative atomic mass
<b>X</b>	X = atomic symbol
b	b = atomic (proton) number

The volume of one mole of any gas is 24 dm<sup>3</sup> at room temperature and pressure (r.t.p.).