



Cambridge International Examinations
Cambridge International General Certificate of Secondary Education

CANDIDATE
NAME

CENTRE
NUMBER

--	--	--	--

CANDIDATE
NUMBER

--	--	--	--



CO-ORDINATED SCIENCES

0654/53

Paper 5 Practical Test

October/November 2015

2 hours

Candidates answer on the Question Paper.

Additional Materials: As listed in the Confidential Instructions.

READ THESE INSTRUCTIONS FIRST

Write your Centre number, candidate number and name on all the work you hand in.

Write in dark blue or black pen.

You may use an HB pencil for any diagrams or graphs.

Do not use staples, paper clips, glue or correction fluid.

DO **NOT** WRITE IN ANY BARCODES.

Answer **all** questions.

Electronic calculators may be used.

You may lose marks if you do not show your working or if you do not use appropriate units.

Notes for Use in Qualitative Analysis for this paper are printed on page 12.

At the end of the examination, fasten all your work securely together.

The number of marks is given in brackets [] at the end of each question or part question.

For Examiner's Use	
1	
2	
3	
Total	

This document consists of **10** printed pages and **2** blank pages.

- 1 Emperor penguins live and breed in the Antarctic. Their average body temperature needs to be maintained at 39°C but air temperature can fall as low as -40°C .

Penguins often huddle together in groups. You are going to investigate how this behaviour may be beneficial by using test-tubes to represent penguins.

- (a) Read through the whole of part (b) before you start the experiment.

Use the information in part (b) to complete the headings in Table 1.1, including any units. [2]

- (b)
- Place into a large beaker the set of three test-tubes that are held together by a rubber band. This is beaker **A**.
 - Place the individual large test-tube into a second beaker. This is beaker **B**.
 - Pour some of the hot water provided into each of the four test-tubes to the lines already drawn on them.
 - Place one thermometer into one of the test-tubes in beaker **A** and the other one into the test-tube in beaker **B**.
 - Measure the temperature to the nearest 0.5°C of the hot water in **A** and **B**. Record the temperatures in Table 1.1 at time 0.
 - Immediately start the stopclock.
 - After two minutes measure the temperature in **A** and **B** and record these temperatures in Table 1.1. Repeat this at two minute intervals for 10 minutes.

Table 1.1

.....
0		
2		
4		
6		
8		
10		

[5]

- (c) On the grid provided on the next page, plot a graph of temperature against time for **A** and **B**. Draw a best-fit smooth curve for each set of readings.

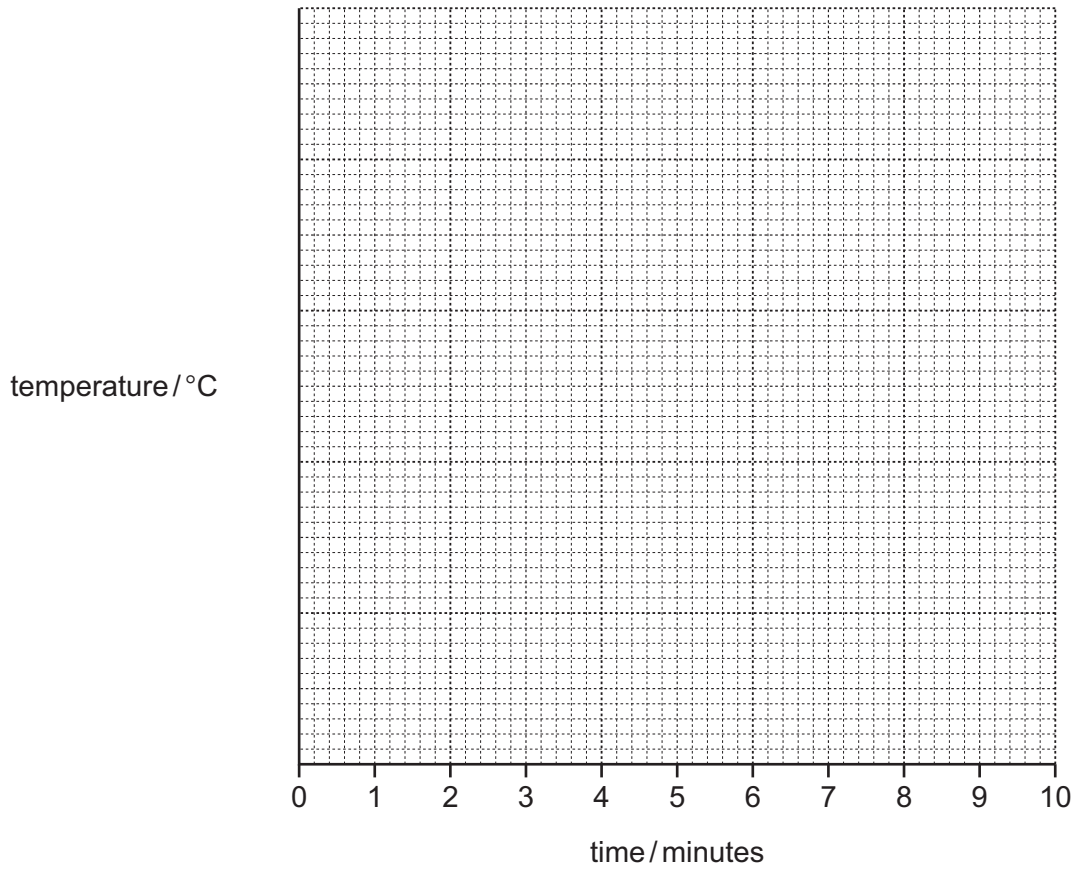

[3]

(d) By referring to your results, suggest why forming a huddle may be beneficial to Emperor Penguins.

.....
.....
..... [2]

(e) (i) Suggest **one** source of inaccuracy in this experiment.

..... [1]

(ii) Suggest how this experiment could be changed to reduce this source of inaccuracy.

..... [1]

(f) Describe and explain how the results from this experiment could be made more reliable.

.....
..... [1]

- 2 You are going to investigate the effect of solution **X** on the exothermic reaction between zinc and copper sulfate solution.

You will carry out three different experiments. All temperatures should be recorded to the nearest 0.5 °C.

(a) Experiment 1

- Measure to the nearest 0.5 °C the initial temperature T_1 of the copper sulphate solution. Record in the correct box in Table 2.1 this temperature for experiment 1.
- Place one of the portions of zinc in the plastic cup.
- Using the measuring cylinder add 10 cm³ of copper sulfate solution to the zinc in the plastic cup.
- Stir the mixture in the plastic cup continuously and measure to the nearest 0.5 °C the highest temperature T_2 of the mixture. Record, in the correct box in Table 2.1, this temperature for experiment 1.
- Look at the mixture and record your observations.

observations

.....

..... [4]

- Discard the mixture into the waste container provided and thoroughly wash out the plastic cup and the measuring cylinder with water.

Table 2.1

experiment	$T_1/^\circ\text{C}$	$T_2/^\circ\text{C}$	$\Delta T/^\circ\text{C}$	volume of solution X used / cm ³
1				0
2				5
3				10

(b) Experiment 2

In this experiment solution **X** and copper sulfate are mixed and filtered before being added to the zinc.

- (i) • Using the measuring cylinder place 10 cm^3 of copper sulfate solution in a small beaker.
- Using the other measuring cylinder add 5 cm^3 of solution **X** to the same beaker.
 - Stir the mixture in the beaker a few times. You will use this mixture in **(b)(ii)**.
 - Look at the mixture and record your observations.

observations

..... [1]

- (ii) • Filter the mixture from **(b)(i)** into a large test-tube.
- Measure the initial temperature T_1 of the filtrate. Record in Table 2.1 T_1 for experiment **2**.
 - Place one of the portions of zinc in the plastic cup.
 - Using a clean measuring cylinder add 10 cm^3 of the filtrate to the zinc in the plastic cup.
 - Stir the mixture in the plastic cup continuously and measure the highest temperature T_2 of the mixture. Record, in Table 2.1, T_2 for experiment **2**.
 - Discard the mixture into the waste container provided and thoroughly wash out the plastic cup, the beaker and the measuring cylinders with water.

[1]

(c) Experiment 3

- Repeat **(b)** using 10 cm^3 of solution **X** instead of 5 cm^3 in part **(i)**.
- Remember to react only 10 cm^3 of the filtrate with the zinc.
- Record in Table 2.1 T_1 and T_2 for experiment **3**.

[2]

- (d) (i) Calculate the change in temperature ΔT for each experiment. Record these values in Table 2.1.

[2]

- (ii) State how ΔT varies with the amount of solution **X** used.

.....
....., [1]

- (iii) Using your observation in (b)(i), suggest an identity for solution **X**.

solution **X** is [1]

- (iv) Using your results in Table 2.1 and your conclusion in (d)(iii), suggest an explanation for the relationship stated in (d)(ii).

.....
.....
....., [2]

- (e) 10 cm³ of filtrate was added to the zinc in experiments **2** and **3** rather than all of the filtrate from the mixture of solution **X** and copper sulfate solution.

Suggest a reason for this.

.....
.....
....., [1]

- 3 You are going to investigate how the height of the shadow cast by an object on a screen changes as the distance from the object to the screen is varied.

The lamp and screen have been set up for you as shown in Fig. 3.1.

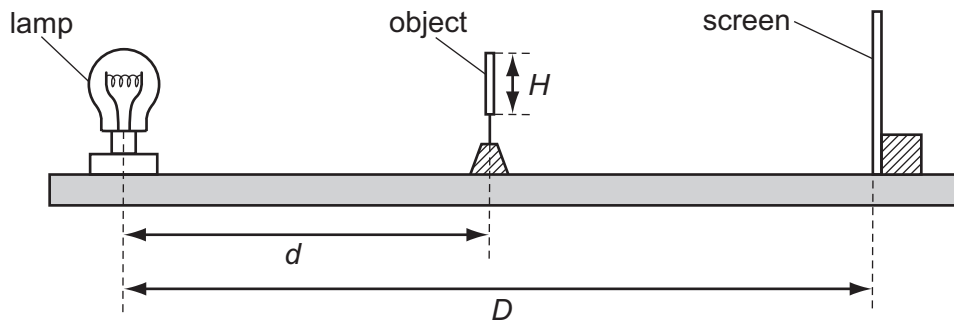

Fig. 3.1

Place the screen at a distance D of 60 cm from the centre of the lamp. **Distance D must not change during the experiment.**

- (a) (i) Measure and record the height H of the object to the nearest 0.1 cm.

$H =$ cm [2]

- (ii) Place the object at a distance d of 55 cm from the **centre of the lamp**. The object will produce a shadow on the screen. Measure and record, in Table 3.1 on page 8, the maximum height h of the shadow to the nearest 0.1 cm. See Fig. 3.2. [1]

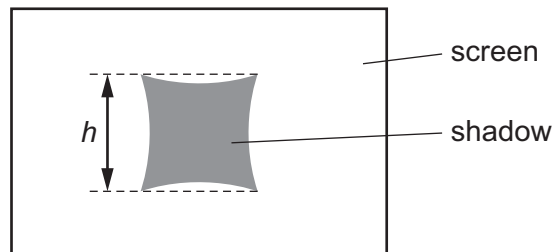

Fig. 3.2

(iii) Repeat (a)(ii) for values of d of 50 cm, 45 cm, 40 cm and 35 cm. [3]

(iv) State **one** difficulty you encountered when measuring the height of the shadow.

.....
, [1]

Table 3.1

d/cm	h/cm
55	
50	
45	
40	
35	

(b) On the grid provided on page 9, plot a graph of h (vertical axis) against d (horizontal axis). Label the axes. Draw the best-fit curve. [3]

(c) (i) Use your graph to predict the height h of the shadow for a value of $d = 30$ cm.

When $d = 30$ cm, $h =$ cm [1]

(ii) The height H of the object may be calculated using the value of h you found in (c)(i) by the equation

$$H = \frac{h}{2}$$

Determine the height of the object using this equation. Show your working.

$H =$ cm [2]

(iii) Extend the curve on your graph to predict the height of the shadow when $d = 10$ cm.

When $d = 10$ cm, $h =$ cm [1]

(d) A student suggests that the distance d between the lamp and the object should be no less than 15 cm. Look at your results and the observations you made whilst performing the experiment and give **one** reason why this is a sensible suggestion.

reason, [1]

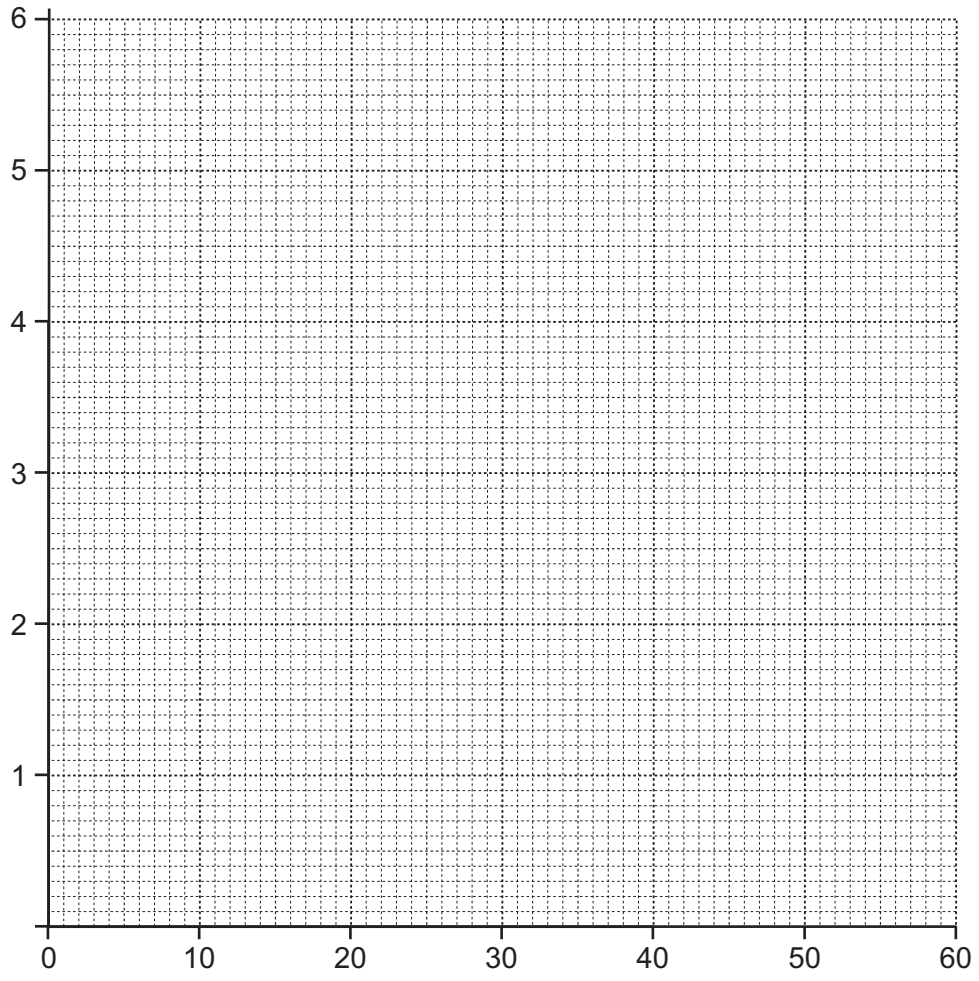

NOTES FOR USE IN QUALITATIVE ANALYSIS

Test for anions

<i>anion</i>	<i>test</i>	<i>test result</i>
carbonate (CO_3^{2-})	add dilute acid	effervescence, carbon dioxide produced
chloride (Cl^-) [in solution]	acidify with dilute nitric acid, then add aqueous silver nitrate	white ppt.
nitrate (NO_3^-) [in solution]	add aqueous sodium hydroxide then aluminium foil; warm carefully	ammonia produced
sulfate (SO_4^{2-}) [in solution]	acidify then add aqueous barium chloride <i>or</i> aqueous barium nitrate	white ppt.

Test for aqueous cations

<i>cation</i>	<i>effect of aqueous sodium hydroxide</i>	<i>effect of aqueous ammonia</i>
ammonium (NH_4^+)	ammonia produced on warming	-
copper(II) (Cu^{2+})	light blue ppt., insoluble in excess	light blue ppt., soluble in excess giving a dark blue solution
iron(II) (Fe^{2+})	green ppt., insoluble in excess	green ppt., insoluble in excess
iron(III) (Fe^{3+})	red-brown ppt., insoluble in excess	red-brown ppt., insoluble in excess
zinc (Zn^{2+})	white ppt., soluble in excess giving a colourless solution	white ppt., soluble in excess giving a colourless solution

Test for gases

<i>gas</i>	<i>test and test results</i>
ammonia (NH_3)	turns damp red litmus paper blue
carbon dioxide (CO_2)	turns limewater milky
chlorine (Cl_2)	bleaches damp litmus paper
hydrogen (H_2)	“pops” with a lighted splint
oxygen (O_2)	relights a glowing splint

Permission to reproduce items where third-party owned material protected by copyright is included has been sought and cleared where possible. Every reasonable effort has been made by the publisher (UCLES) to trace copyright holders, but if any items requiring clearance have unwittingly been included, the publisher will be pleased to make amends at the earliest possible opportunity.

To avoid the issue of disclosure of answer-related information to candidates, all copyright acknowledgements are reproduced online in the Cambridge International Examinations Copyright Acknowledgements Booklet. This is produced for each series of examinations and is freely available to download at www.cie.org.uk after the live examination series.

Cambridge International Examinations is part of the Cambridge Assessment Group. Cambridge Assessment is the brand name of University of Cambridge Local Examinations Syndicate (UCLES), which is itself a department of the University of Cambridge.