



**Cambridge International Examinations**  
Cambridge International General Certificate of Secondary Education

CANDIDATE  
NAME

CENTRE  
NUMBER

--	--	--	--	--

CANDIDATE  
NUMBER

--	--	--	--



**CO-ORDINATED SCIENCES**

**0654/63**

Paper 6 Alternative to Practical

**October/November 2015**

**1 hour**

Candidates answer on the Question Paper.

No Additional Materials are required.

**READ THESE INSTRUCTIONS FIRST**

Write your Centre number, candidate number and name on all the work you hand in.

Write in dark blue or black pen.

You may use an HB pencil for any diagrams or graphs.

Do not use staples, paper clips, glue or correction fluid.

**DO NOT WRITE IN ANY BARCODES.**

Answer **all** questions.

Electronic calculators may be used.

You may lose marks if you do not show your working or if you do not use appropriate units.

At the end of the examination, fasten all your work securely together.

The number of marks is given in brackets [ ] at the end of each question or part question.

This document consists of **19** printed pages and **1** blank page.

- 1 Emperor penguins live and breed in the Antarctic. Their average body temperature needs to be maintained at  $39^{\circ}\text{C}$  but air temperature can fall as low as  $-40^{\circ}\text{C}$ .

Penguins often huddle together. A student investigates how this behaviour may be beneficial to the penguins by using test-tubes to represent them.

- The student places a set of three large test-tubes that are held together with a rubber band into a large beaker labelled **A**. He then places an individual large test-tube into a second beaker labelled **B**.
- He takes the temperature of a beaker of hot water. He records this in Table 1.1 as the temperature at time zero.
- He immediately pours equal amounts of the hot water into each of the four test-tubes as shown in Fig. 1.1.

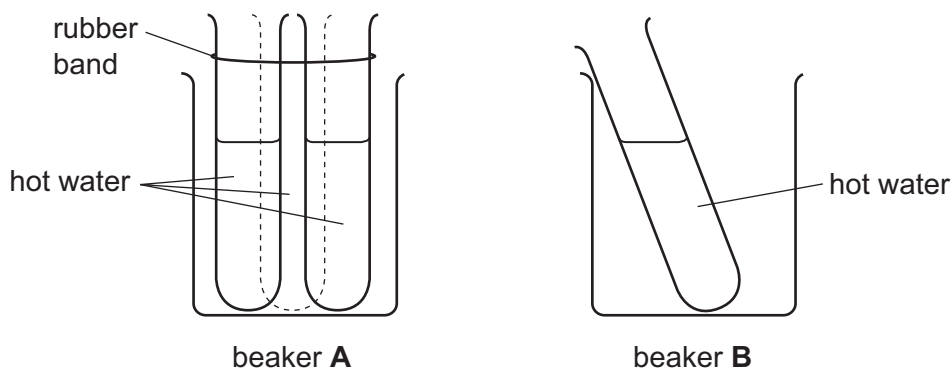

**Fig. 1.1**

- He starts a stopclock and immediately places a thermometer into the test-tube in beaker **B** and a second thermometer into **one** of the test-tubes in beaker **A**.
- After two minutes he records the temperature of the water in both test-tubes. He repeats this at two minute intervals for 10 minutes.
- His results table is shown in Table 1.1.

**Table 1.1**

time / .....	temperature recorded in beaker <b>A</b> / $^{\circ}\text{C}$	temperature recorded in beaker <b>B</b> / $^{\circ}\text{C}$
0	81.0	81.0
2	68.0	67.6
4	64.2	61.8
6	61.0	57.0
8	58.2	53.0
10	56.0	49.6

(a) Complete the heading for the first column in Table 1.1. [1]

(b) On the grid provided, plot a graph of temperature (vertical axis) against time for both beakers. Draw a smooth best-fit curve for each set of readings.

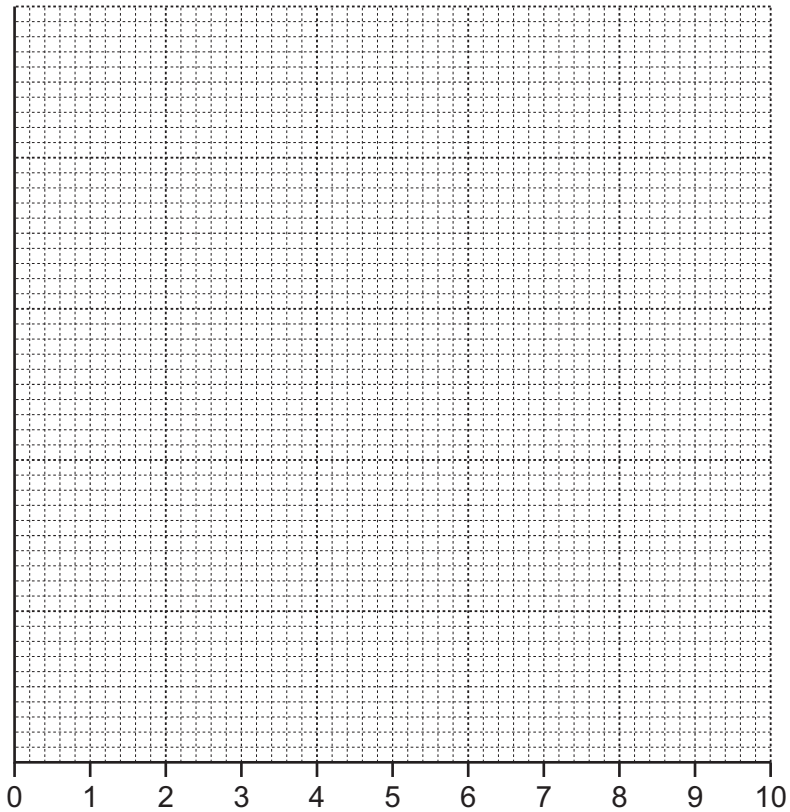

[4]

(c) Refer to the results to suggest why forming a huddle may be beneficial to Emperor Penguins.

.....  
.....  
....., [2]

(d) (i) Suggest **one** source of inaccuracy in this experiment. [1]

(ii) Suggest how this experiment could be changed to reduce this source of inaccuracy. [1]

.....  
....., [1]

(e) Describe how the results from this experiment could be made more reliable.

.....  
....., [1]

- 2 A student investigates the effect of solution **X** on the exothermic reaction between zinc and copper sulfate solution.

He uses three procedures. He is given copper sulfate solution, a beaker containing unknown solution **X** and three 0.5 g samples of zinc powder.

#### Procedure 1

- Place  $10\text{ cm}^3$  of the copper sulfate solution into a plastic cup. Add  $10\text{ cm}^3$  of water and stir well.
- Measure the temperature  $T_1$  of the solution and record it in Table 2.1.
- Add 0.5 g of zinc powder and stir well.
- Find the highest temperature  $T_2$  of the mixture and record it in Table 2.1.

#### Procedure 2

- Place  $10\text{ cm}^3$  of the copper sulfate solution into a beaker. Add  $5\text{ cm}^3$  of solution **X** plus  $5\text{ cm}^3$  of water and stir well.
- Filter the mixture to remove the light blue precipitate.
- Measure  $10\text{ cm}^3$  of the filtrate and follow the method for **Procedure 1** using this filtrate instead of copper sulfate solution.

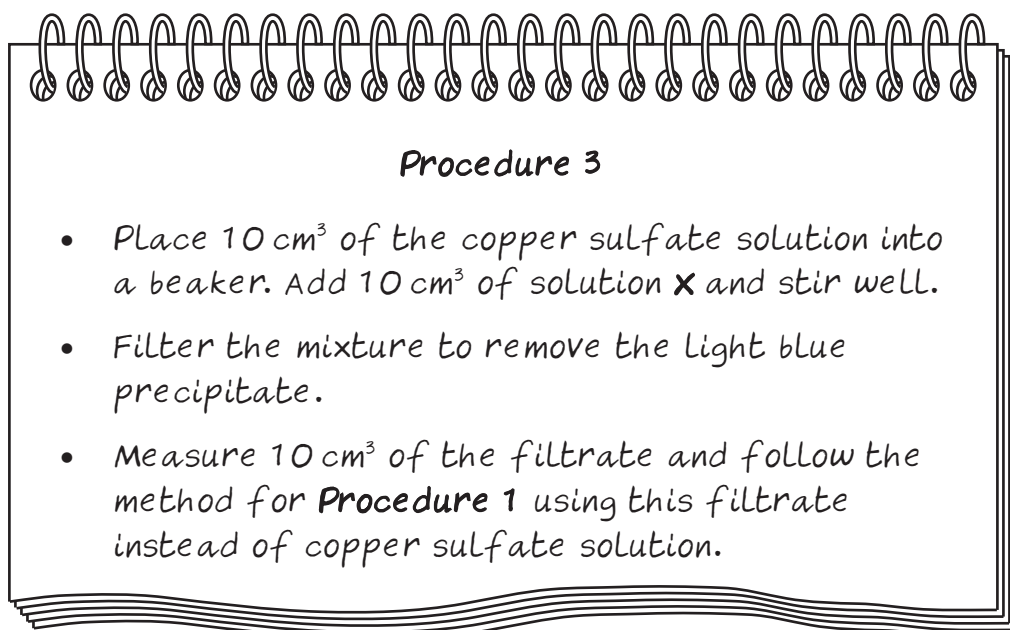
**Table 2.1**

procedure	volume of solution X used/cm <sup>3</sup>	temperature/°C		temperature change/°C
		$T_1$	$T_2$	$T_2 - T_1$
<b>1</b>	0	20.0		
<b>2</b>	5	20.0		
<b>3</b>	10	21.5		

- (a) (i) Fig. 2.1 shows the thermometer scales for the highest temperature  $T_2$  reached in each of the three procedures. Read the temperatures to the nearest 0.5°C and record them in Table 2.1. [3]

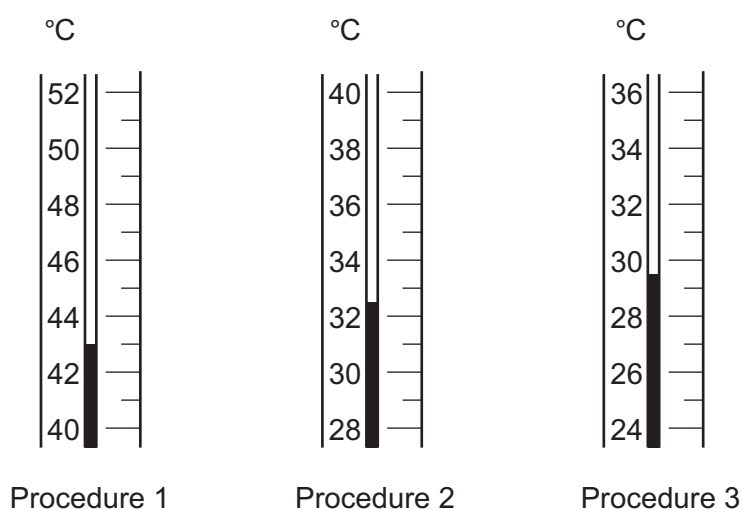
**Fig. 2.1**

(ii) Calculate the temperature changes and complete the last column of Table 2.1.

[1]

(b) (i) State the trend in temperature changes as the volume of solution **X** used changes.

.....  
..... [1]

(ii) Suggest an explanation for the trend you have stated in part (i).

.....  
.....  
..... [2]

(c) Suggest a chemical name for the solution **X** that produces the light blue precipitate.

..... [1]

(d) Suggest a reason why the student uses a plastic cup rather than a glass beaker for the exothermic reaction.

.....  
..... [1]

(e) Suggest a reason why only 10 cm<sup>3</sup> of the filtrate, instead of all of it, is added to the zinc in **Procedure 2** and **Procedure 3**.

.....  
..... [1]





- 3 A science student investigates how the size of a shadow cast by an object varies with the distance of the object from the lamp.

The apparatus he uses is shown in Fig. 3.1. The diagram is not to scale.

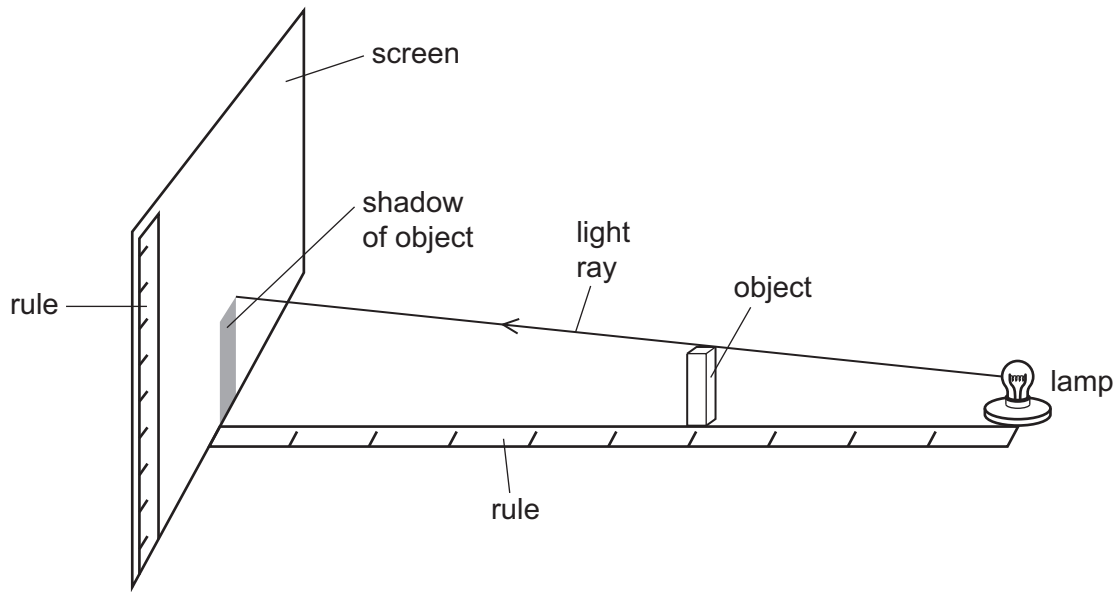

**Fig. 3.1**

- (a) (i) Fig. 3.2 shows the actual size of the object. Use a ruler to measure  $H$ , the height of the object to the nearest 0.1 cm.

$H$ , height of the object = ..... cm [1]

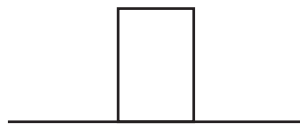

**Fig. 3.2**

- (ii) Use Fig. 3.1 to help you suggest why a shadow is formed.

.....  
 ....., [1]

The student measures the height  $h$  of the shadow formed when the object is placed at distances  $d = 55$  cm,  $d = 45$  cm, and  $d = 35$  cm from the lamp. He records his measurements in Table 3.1.

**Table 3.1**

$d/\text{cm}$	15	25	35	45	55
$h/\text{cm}$			2.6	2.0	1.6

**(b)** Fig. 3.3 shows the shadows produced when the object is placed at 15 cm and 25 cm from the lamp.

Use a ruler to measure the missing values of  $h$  to the nearest 0.1 cm.

Record these values in Table 3.1.

[2]

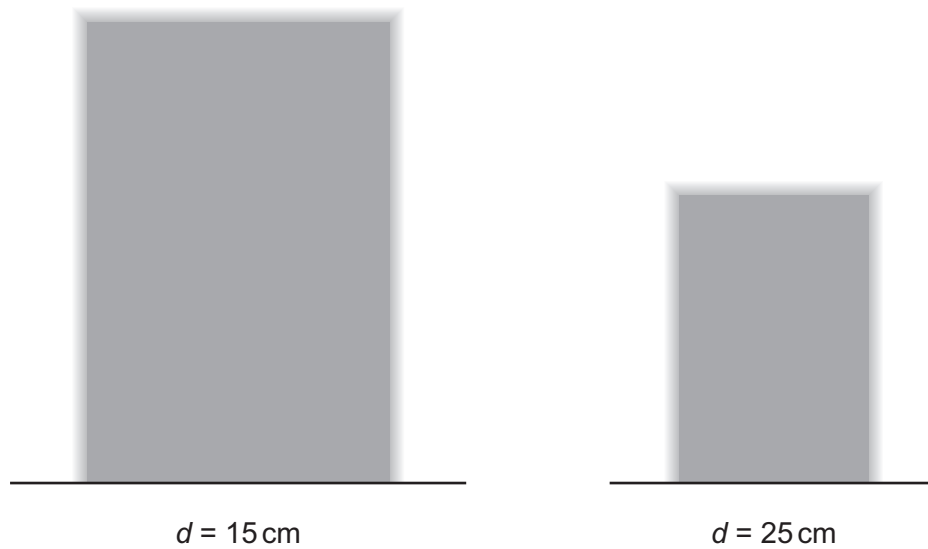

**Fig. 3.3**

(c) (i) On the grid provided, plot a graph of  $h$  against  $d$ . Draw the best-fit curve.

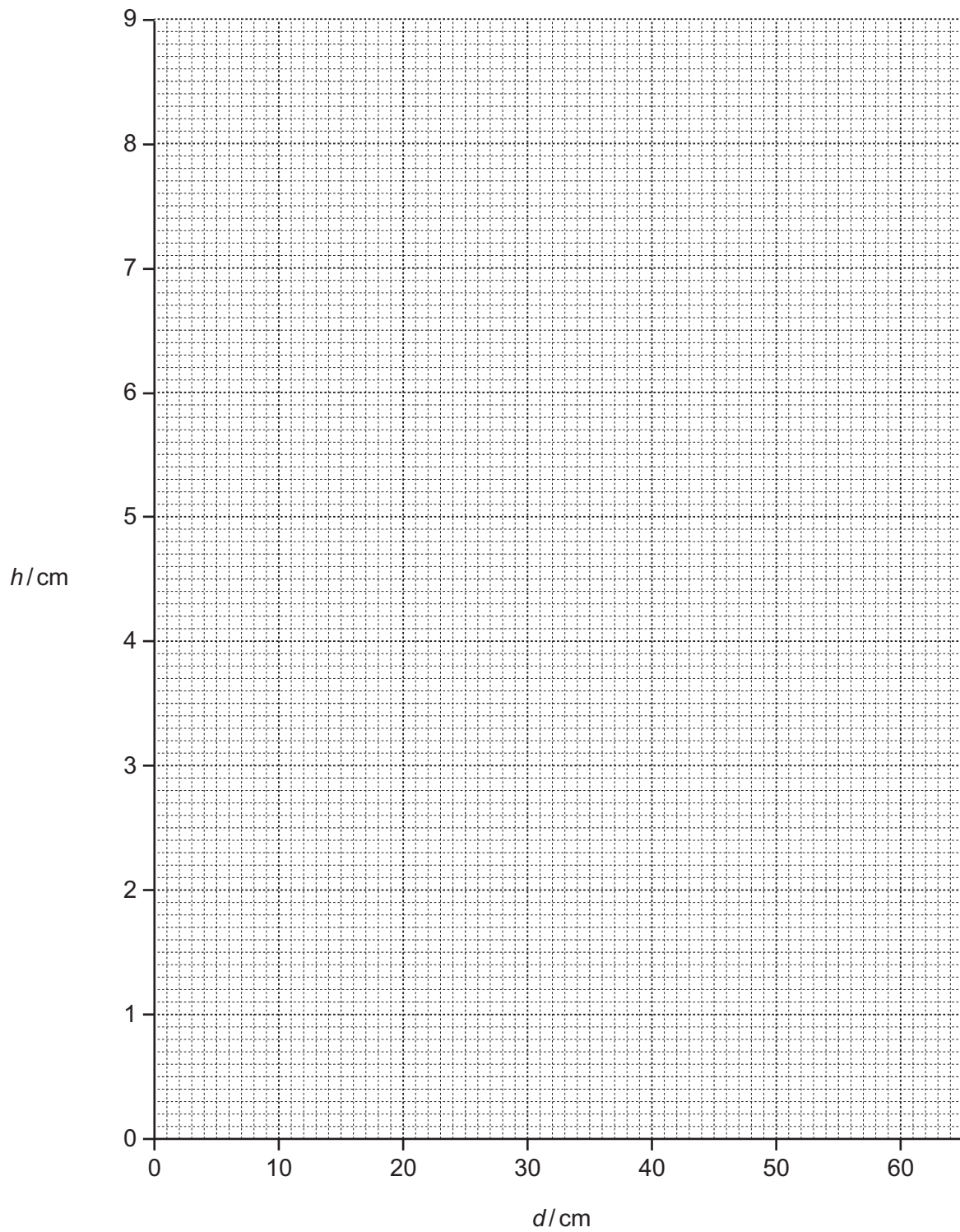

[2]

- (ii) The student suggests that the height of the shadow for  $d = 30$  cm,  $h_{30}$ , is equal to twice the actual height of the object. He has written an equation:

$$h_{30} = 2H$$

Use your graph to show if he is correct. Show your working on the graph and then write your conclusion.

conclusion: .....

..... [2]

- (d) (i) Extend your curve to predict the height of the shadow when  $d = 10$  cm.

height = ..... cm [1]

- (ii) State **one** problem that the student might find if  $d$  is reduced to 5 cm.

..... [1]

**Please turn over for Question 4.**

4 A student investigates respiration in woodlice.

She sets up the airtight apparatus shown in Fig. 4.1. The soda lime absorbs carbon dioxide.

Every minute for 4 minutes she records the position of the oil drop in the capillary tube and records her results in Table 4.1.

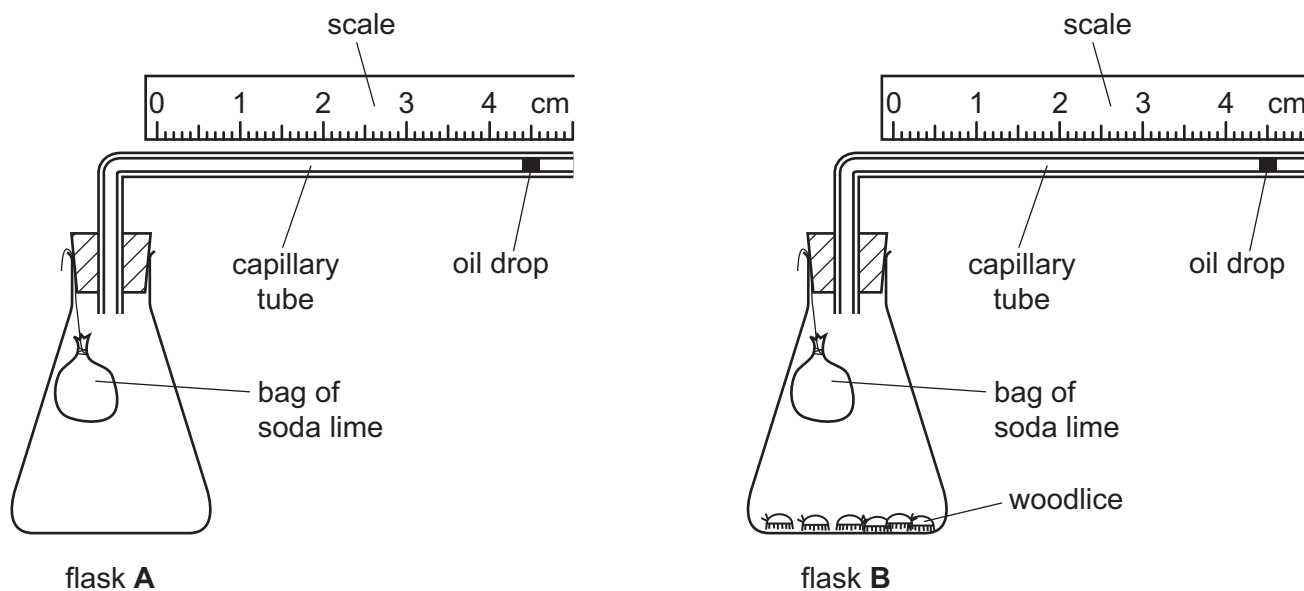

Fig. 4.1

(a) Explain why flask **A** is used in this experiment.

.....

..... [1]

(b) (i) Use the diagrams in Fig. 4.2 to complete the results in Table 4.1 for time = 2 minutes. The student uses the left edge of the oil drop to record her initial readings.

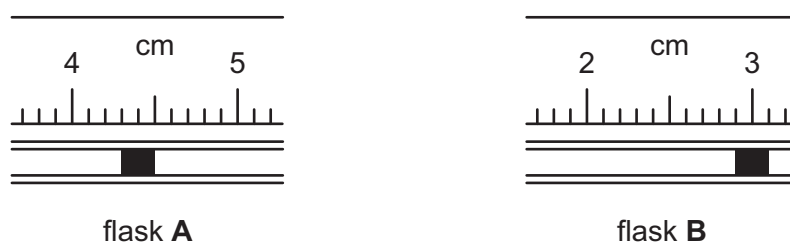

Fig. 4.2

- (ii) Complete Table 4.1 to show the total distance moved by the oil drop for each flask. [2]

**Table 4.1**

time / minutes	position of oil drop / cm	
	beaker <b>A</b>	beaker <b>B</b>
0	4.4	4.4
1	4.4	3.6
2		
3	4.3	2.1
4	4.3	1.3
total distance moved by oil drop / cm		

[1]

- (c) (i) The oil drop for flask **A** moves slightly during the experiment. Suggest why it moves.

.....  
 ....., [1]

- (ii) Suggest how the experiment could be changed to prevent the oil drop for flask **A** moving.

.....  
 ....., [1]

- (d) Explain why the oil drop in flask **B** moves further than in flask **A**.

.....  
 .....  
 .....  
 ....., [3]

- (e) Suggest how the results of this experiment would change if twice as many woodlice were used in flask **B**.

..... [1]

- 5 The science class compares the reactivity of two metals with acid. The apparatus they use is shown in Fig. 5.1.

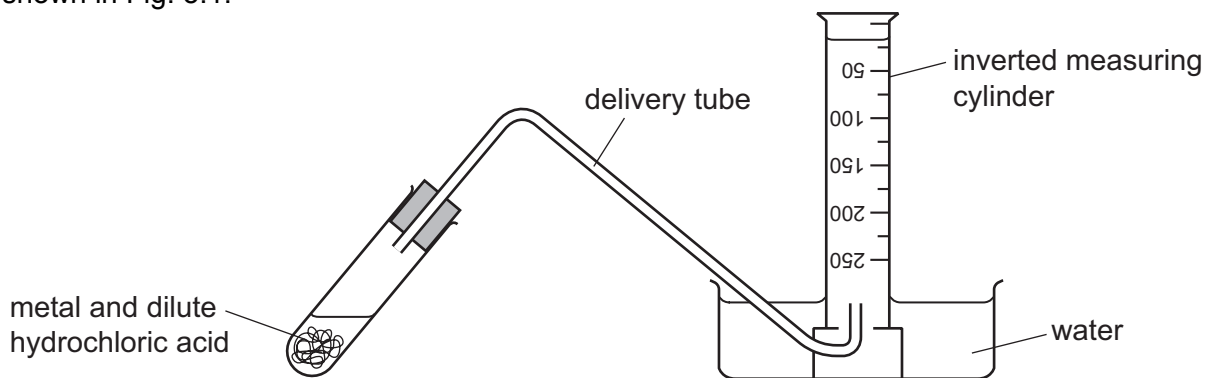

Fig. 5.1

### experimental method

- The inverted measuring cylinder is filled with water.
- Magnesium is added to 10 cm<sup>3</sup> of hydrochloric acid and a stopclock is started.
- The volume of hydrogen collected in the measuring cylinder is recorded every 30 seconds for two minutes.
- The experiment is repeated using the same mass of zinc instead of magnesium.
- A graph of volume of hydrogen against time is plotted for each metal.

Fig. 5.2 shows the graph for magnesium.

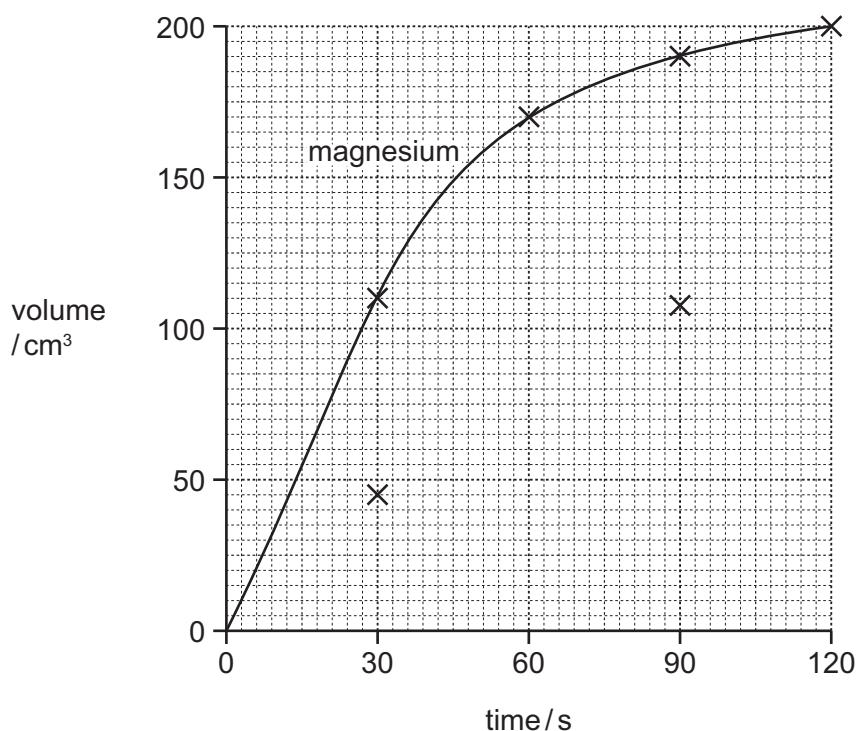
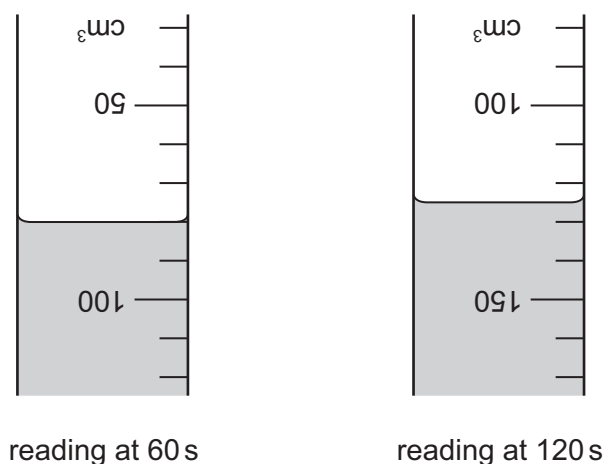

Fig. 5.2

The student has not finished plotting the data for zinc.



Fig. 5.3 shows the measuring cylinder for the reaction of zinc with hydrochloric acid at 60 and 120 seconds.



**Fig. 5.3**

**(a) (i)** Read the scales of the measuring cylinders in Fig. 5.3 and record the volumes of gas.

volume of gas at 60 s = ..... cm<sup>3</sup>

volume of gas at 120 s = ..... cm<sup>3</sup> [2]

**(ii)** Use the readings from **(a)(i)** to complete the graph for zinc.

Draw the best fit curve for zinc. [3]

**(b)** State a property of hydrogen gas that enables the student to collect it over water.

.....  
 ....., [1]

**(c)** Explain why the graph for magnesium is steep for the first 30 seconds, then becomes less steep, nearly levelling out towards the end.

.....  
 .....  
 .....  
 ....., [3]

**(d)** Suggest why the graph for zinc is lower than the graph for magnesium.

.....  
 ....., [1]

- 6 A student investigates how the volume of a gas changes as the temperature changes. He sets up the apparatus as shown in Fig. 6.1.

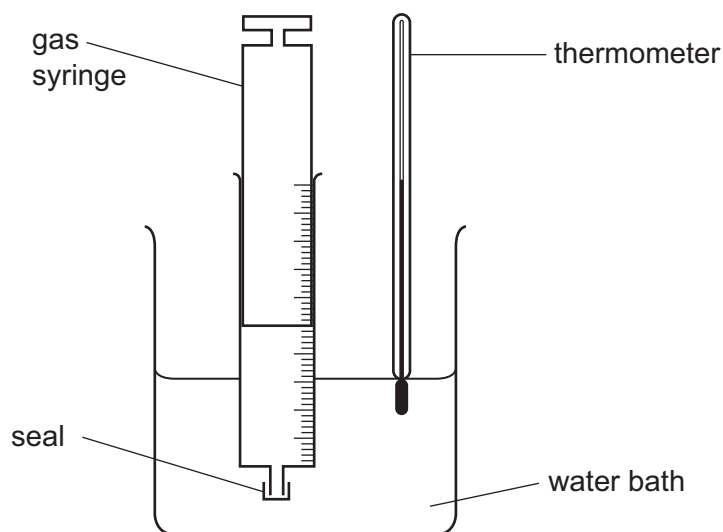

**Fig. 6.1**

- The student draws  $50\text{ cm}^3$  of dry air at room temperature into a gas syringe and seals the syringe.
- He measures the room temperature and records in Table 6.1 the temperature and volume of air, to the nearest  $1^\circ\text{C}$  and  $1\text{ cm}^3$ .
- He places the syringe in a warm water-bath and leaves it for several minutes.
- He records in Table 6.1 the temperature of the water-bath and the volume of the air.
- He increases the temperature of the water-bath and after several minutes he records the temperature and volume as before.
- Finally, he cools the syringe to a temperature of  $0^\circ\text{C}$  and finds the new volume of the air.

**Table 6.1**

volume of air / $\text{cm}^3$	70			64
temperature / $^\circ\text{C}$	21			0

(a) Fig. 6.2 shows the syringe and thermometer readings missing from Table 6.1.

Read the scales and record the readings in Table 6.1, to the nearest 1 °C and 1 cm<sup>3</sup>.

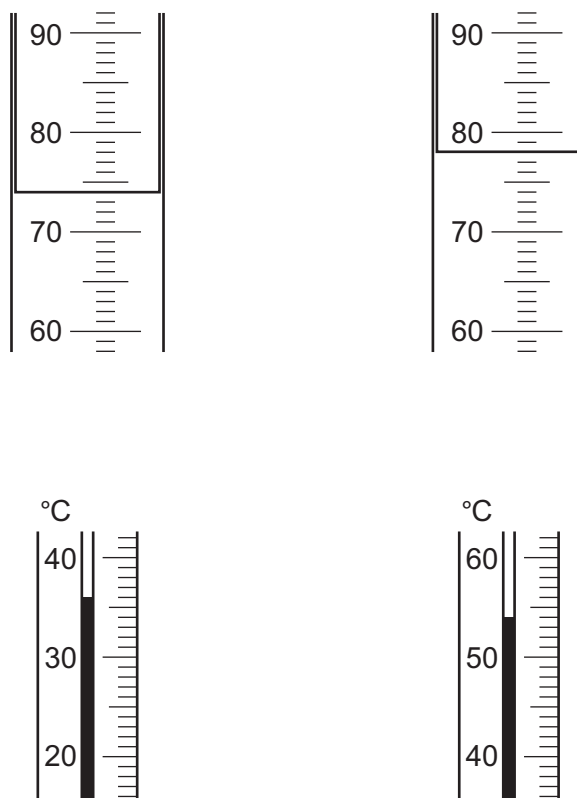

Fig. 6.2

[2]

(b) (i) Suggest a reason why the student leaves the syringe in the water at the higher temperatures for several minutes.

.....  
 ....., [1]

(ii) Suggest how the student can cool the syringe down and keep it at a temperature of 0 °C. He has supplies of ice and salt.

.....  
 ....., [1]

(c) Explain why a **rise** in the temperature of the air causes its volume, measured at atmospheric pressure, to increase.

.....  
 .....  
 ....., [2]

- (d) The student repeats all the steps of this experiment using  $50 \text{ cm}^3$  of gas **G** instead of  $50 \text{ cm}^3$  of air. He uses the same temperatures as before.

He finds that the volumes of gas **G** at the higher temperatures are the same as the volumes of air.

The syringe reading for gas **G** at  $0^\circ\text{C}$  is close to  $0 \text{ cm}^3$ .

Suggest a reason why the volume of gas **G** at  $0^\circ\text{C}$  was close to zero.

..... [1]

- (e) Study Fig. 6.1 again and identify **two** sources of error in the student's experiment.

error 1 .....

error 2 .....

[2]

- (f) Mark on Fig. 6.1, with the letter C, where the student should clamp the syringe. [1]

---

Permission to reproduce items where third-party owned material protected by copyright is included has been sought and cleared where possible. Every reasonable effort has been made by the publisher (UCLES) to trace copyright holders, but if any items requiring clearance have unwittingly been included, the publisher will be pleased to make amends at the earliest possible opportunity.

To avoid the issue of disclosure of answer-related information to candidates, all copyright acknowledgements are reproduced online in the Cambridge International Examinations Copyright Acknowledgements Booklet. This is produced for each series of examinations and is freely available to download at [www.cie.org.uk](http://www.cie.org.uk) after the live examination series.

Cambridge International Examinations is part of the Cambridge Assessment Group. Cambridge Assessment is the brand name of University of Cambridge Local Examinations Syndicate (UCLES), which is itself a department of the University of Cambridge.