



Cambridge International Examinations
Cambridge International General Certificate of Secondary Education

CANDIDATE
NAME

--

CENTRE
NUMBER

--	--	--	--	--

CANDIDATE
NUMBER

--	--	--	--



CO-ORDINATED SCIENCES

0654/21

Paper 2 (Core)

October/November 2016

2 hours

Candidates answer on the Question Paper.

No Additional Materials are required.

READ THESE INSTRUCTIONS FIRST

Write your Centre number, candidate number and name on all the work you hand in.

Write in dark blue or black pen.

You may use an HB pencil for any diagrams or graphs.

Do not use staples, paper clips, glue or correction fluid.

DO NOT WRITE IN ANY BARCODES.

Answer **all** questions.

Electronic calculators may be used.

You may lose marks if you do not show your working or if you do not use appropriate units.

A copy of the Periodic Table is printed on page 32.

At the end of the examination, fasten all your work securely together.

The number of marks is given in brackets [] at the end of each question or part question.

This document consists of **32** printed pages.

1 Scientists can estimate the concentration of carbon dioxide in the Earth’s atmosphere a long time ago. Samples of air can be found trapped in ancient ice.

(a) Table 1.1 shows some results.

Table 1.1

year	carbon dioxide concentration /parts per million
1000	280
1200	275
1400	280
1600	270
1800	280
2000	345

(i) In the year 2000, the carbon dioxide concentration in the trapped air was 345 parts per million.

State the **two** gases that make up most of the rest of the atmosphere.

1

2

[2]

(ii) Using the information in Table 1.1, describe how the carbon dioxide concentration in the Earth’s atmosphere changed between the year 1000 and the year 2000.

.....

[3]

(b) Name a **biological** process that

(i) releases carbon dioxide into the atmosphere,

.....[1]

(ii) removes carbon dioxide from the atmosphere.

.....[1]

(c) Suggest and explain the effect on the carbon dioxide concentration in the Earth's atmosphere of

(i) large-scale deforestation,

.....
.....[1]

(ii) burning fossil fuels.

.....
.....[1]

(d) An increase in carbon dioxide concentration in the Earth's atmosphere could cause global warming.

State **two** undesirable effects of global warming.

1

2

[2]

- 2 Five test-tubes containing different substances are labelled **A**, **B**, **C**, **D** and **E** as shown in Fig. 2.1. Dilute hydrochloric acid is added to each of the five substances.

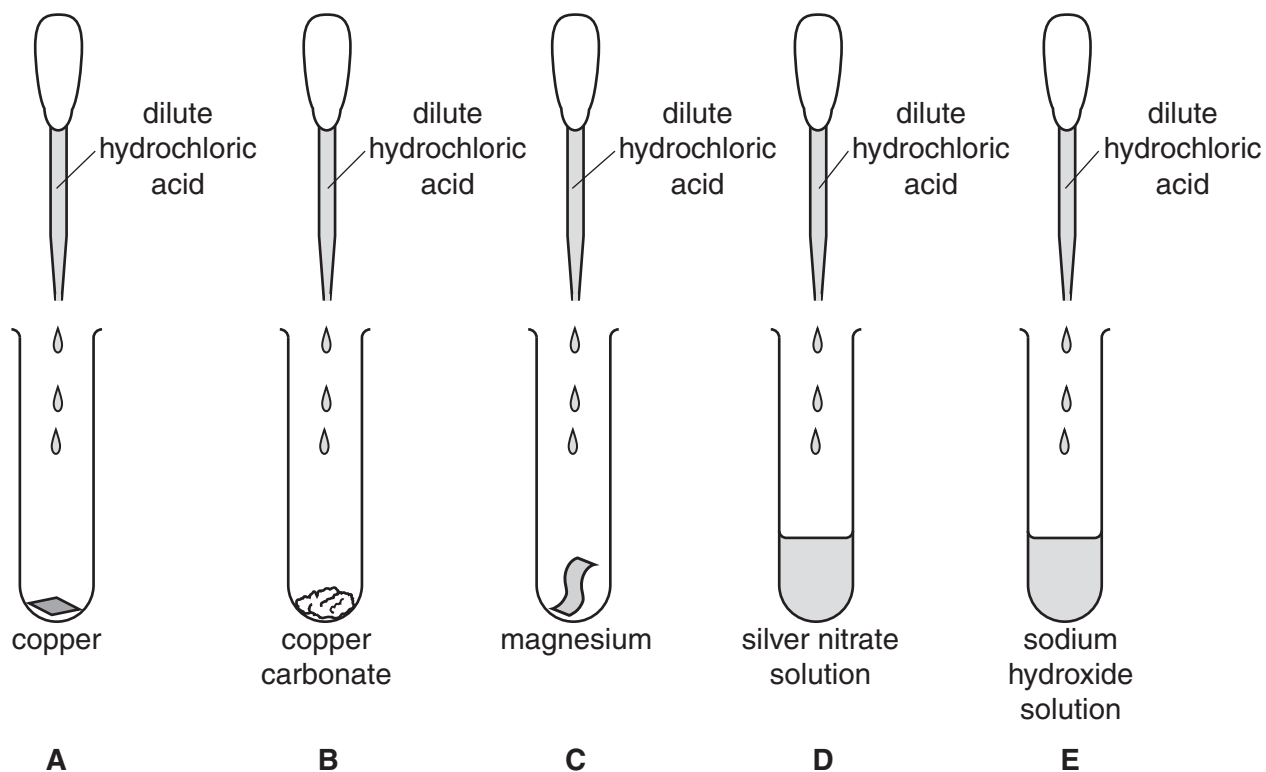

Fig. 2.1

- (a) (i) Suggest the letter of the test-tube containing a substance that releases a gaseous **element** when the dilute hydrochloric acid is added.

Name the gaseous element.

test-tube

gaseous element [1]

- (ii) Suggest the letter of the test-tube containing a substance that releases a gaseous **compound** when the dilute hydrochloric acid is added.

Name the gaseous compound.

test-tube

gaseous compound [1]

- (iii) Dilute hydrochloric acid contains chloride ions in solution.

State the letter of the test-tube in which the hydrochloric acid reacts to form a white solid.

State the name of the white solid produced.

test-tube

white solid [1]

- (b) Vanadium and its compounds are able to act as catalysts.

- (i) State the meaning of the term *catalyst*.

.....

 [2]

- (ii) The chemical symbol for vanadium is shown.



State

- the number of neutrons in the nucleus of this atom,
- the number of electrons in a vanadium atom.

[2]

- (iii) State the name of the collection of metals in the Periodic Table to which vanadium belongs.

..... [1]

- (c) The industrial production of sulfuric acid involves a chemical reaction that uses vanadium oxide as a catalyst.

Fig. 2.2 shows part of the industrial process used to produce sulfuric acid.

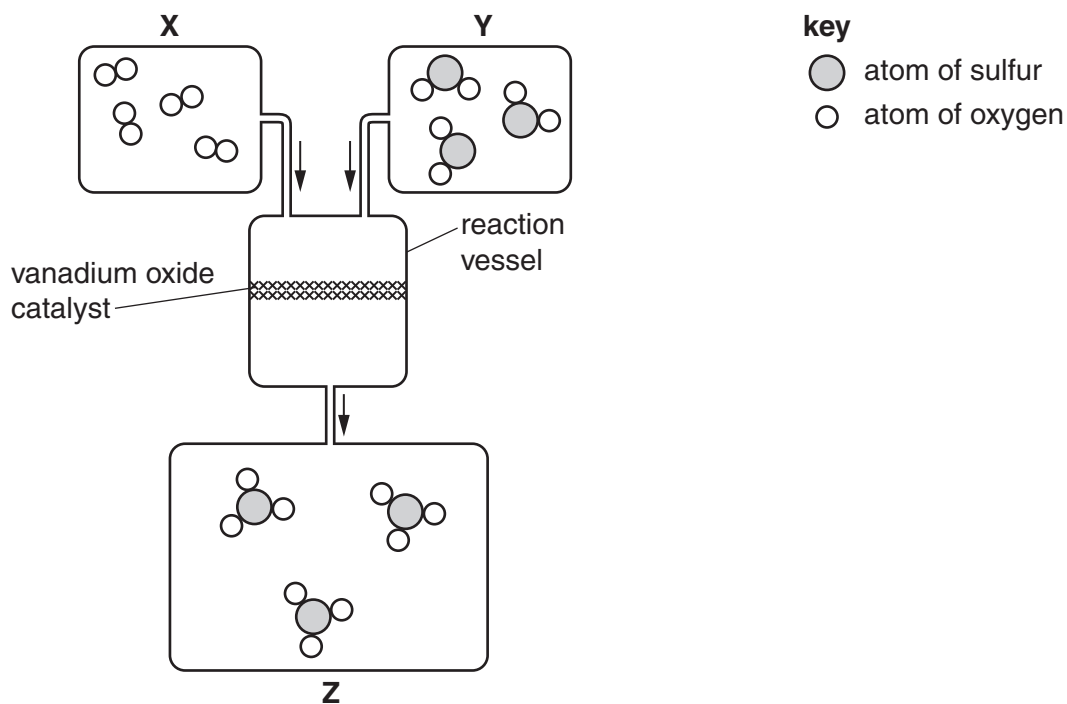

Fig. 2.2

Boxes **X**, **Y** and **Z** contain diagrams that represent the molecules in the reaction.

- (i) State the formula of the molecules shown in box **Z**.

.....

[1]

- (ii) Explain which box, **X** or **Y**, contains molecules that are oxidised in the reaction vessel.

box

explanation

.....[1]

- 3 (a) Three identical kettles have each been filled with the same volume of water at 25 °C.

Fig. 3.1 shows the three kettles a few minutes later.

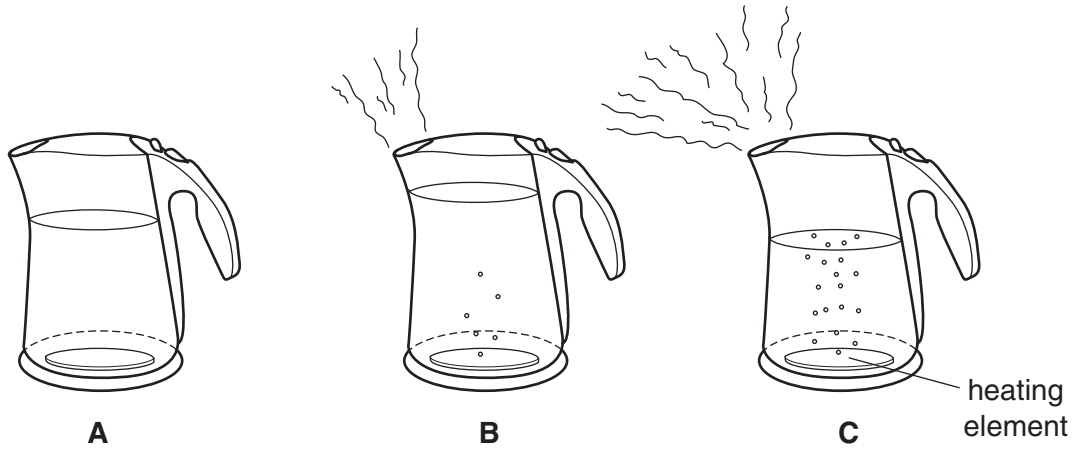

Fig. 3.1

Kettle **A** contains water that remains at 25 °C.

Kettle **B** contains water that is just starting to boil at 100 °C.

Kettle **C** contains water that has been boiling for a few minutes but is still at 100 °C.

- (i) The volume of water in kettle **A** stays the same. There is a small increase in the volume of water in kettle **B**.

Explain why the water volume increases in kettle **B**.

.....
[1]

- (ii) Explain why there is a large difference in the volume of water between kettles **B** and **C**.

.....
[1]

- (iii) Pure water has a boiling point of 100 °C.

State the meaning of the term *boiling point*.

.....
[1]

(iv) When the water boils, some becomes water vapour in the air.

Fig. 3.2 shows the arrangement of particles in a gas, liquid and solid.

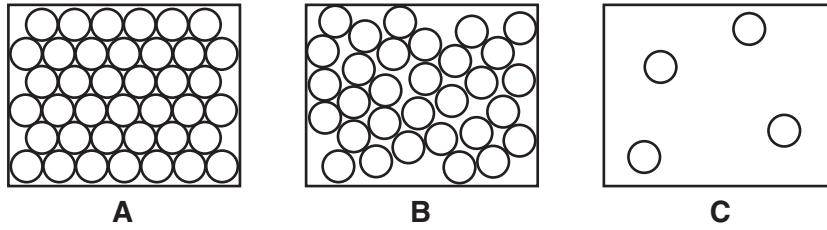

Fig. 3.2

State and explain which diagram, **A**, **B** or **C**, best represents:

water at 25 °C,

explanation

.....

water vapour.

explanation

.....

[2]

(b) The kettles shown in Fig. 3.1 each have a heating element at the bottom.

Name the method by which thermal energy is transferred through the water in the kettles.

..... [1]

(c) A kettle is connected to a 250 V supply. There is a current of 8 A in the heating element.

Calculate the resistance of the heating element.

State the formula you use, show your working and state the unit.

formula

working

resistance = unit = [3]

(d) Fig. 3.3 shows a kettle with a mains lead connected to a plug. Inside the plug there is a fuse.

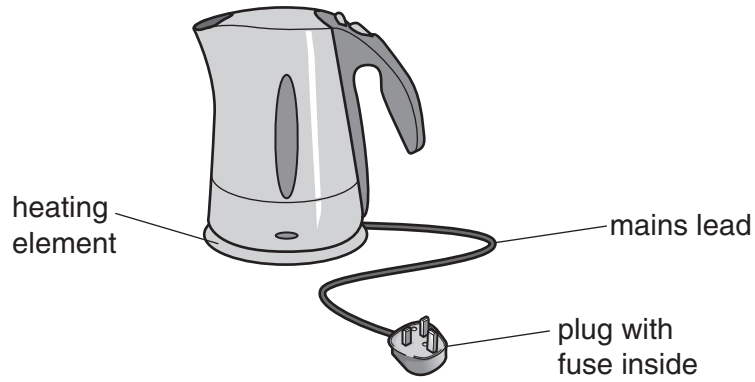

Fig. 3.3

A fuse in the plug protects a person using the kettle from an electric shock.

Describe what happens to the fuse when a short circuit occurs in the kettle.

Explain why this happens.

description

.....
.....

explanation

.....
.....

[2]

- 4 A gardener increases the number of trees by taking cuttings. The gardener cuts off part of a stem (the cutting) and places it in water, as shown in Fig. 4.1.

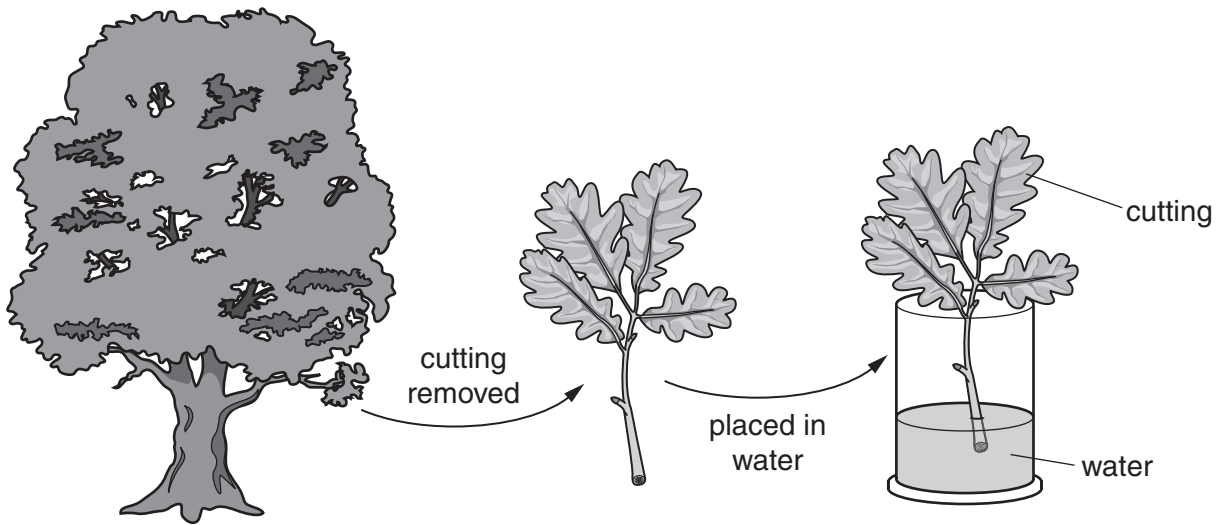

Fig. 4.1

The cutting develops roots as shown in Fig. 4.2. The gardener then plants the cutting in the ground.

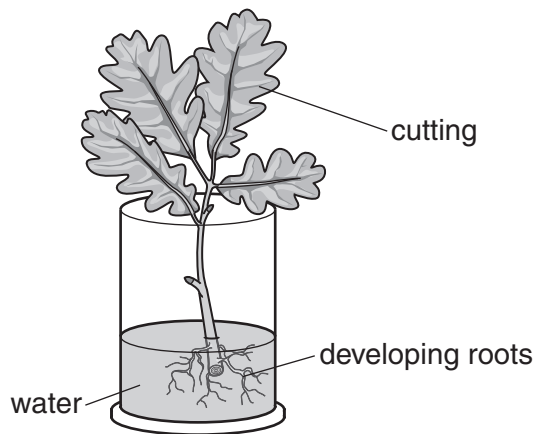

Fig. 4.2

- (a) The cutting grows into a new tree. This is an example of asexual reproduction.

- (i) Define the term *asexual reproduction*.

.....

 [2]

- (ii) For a particular gene, the parent plant has the genotype **Aa**.

Predict what would be the genotype of the cutting.

genotype [1]

- (b) Before the roots develop on a cutting, the gardener encloses the cutting in a plastic bag, as shown in Fig. 4.3. This prevents the cutting from losing too much water before its new roots have grown.

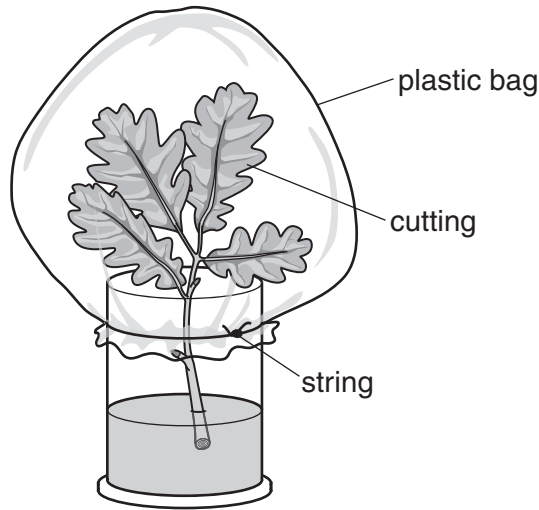

Fig. 4.3

- (i) State the name of
 the cells in the roots of a plant that absorb most of the water,

 the tissue that carries water up from the roots to the leaves,

 the process of evaporation of water from the surfaces of the cells in the leaves.

 [3]
- (ii) Explain why the plastic bag in Fig. 4.3 reduces the amount of water lost from the leaves of the cutting.

 [1]
- (iii) State **two** ways in which the cutting uses the water that it has absorbed.
 1
 2 [2]

- (c) As the cutting develops, it also needs nitrate ions and magnesium ions. These are added to the water.

Describe the importance to the developing cutting of

- (i) nitrate ions,

.....
.....[1]

- (ii) magnesium ions.

.....
.....[1]

- 5 (a) Fig. 5.1 shows the apparatus a teacher uses to demonstrate the reaction between hot magnesium and steam.

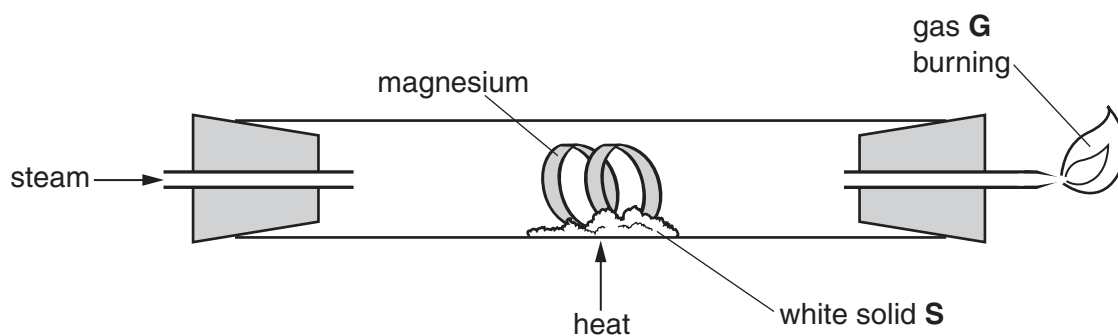

Fig. 5.1

During the reaction a white solid, **S**, and a flammable gas, **G**, are produced.

- (i) Name solid **S** and gas **G**.

solid **S**

gas **G**

[2]

- (ii) Predict and explain what is observed, if anything, when the teacher repeats the experiment using copper instead of magnesium.

observation

explanation

.....

[2]

- (b) Fig. 5.2 shows the apparatus and materials a student uses to study the reaction between magnesium ribbon and excess copper sulfate solution.

She measures the temperature of the solution for ten minutes.

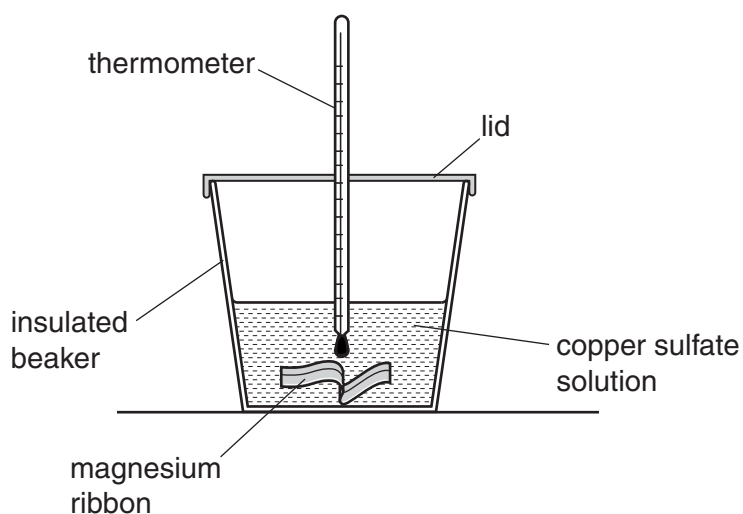

Fig. 5.2

Fig. 5.3 shows a graph of her results.

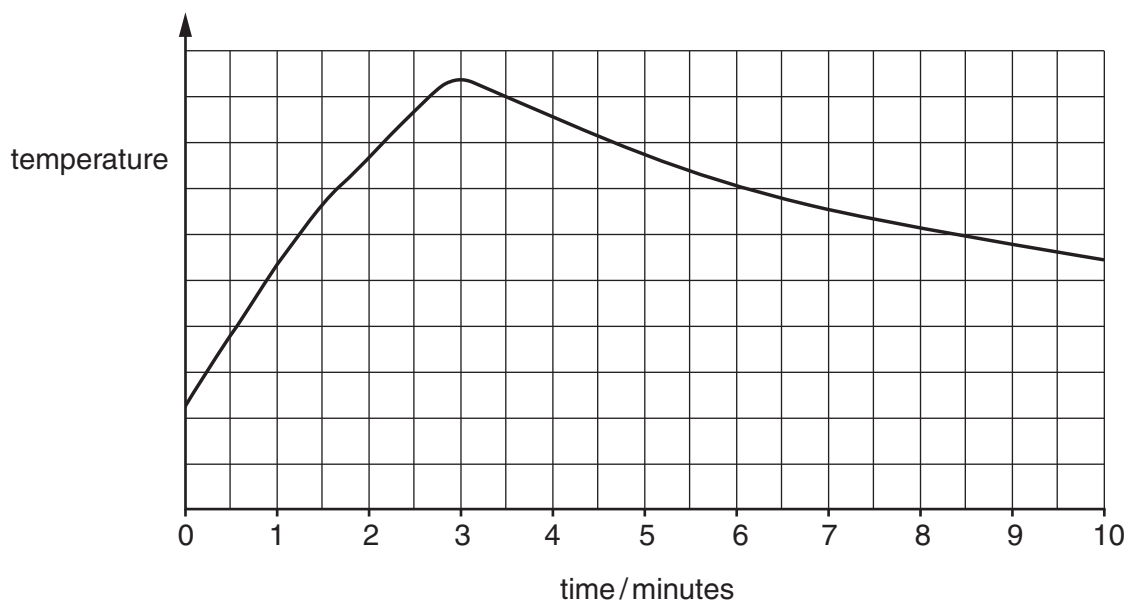

Fig. 5.3

- (i) Explain why the results in Fig. 5.3 show that an exothermic reaction occurs between the magnesium and the copper sulfate solution.

.....
[1]

- (ii) Suggest the time it takes for all of the magnesium to react in this experiment. Give a reason for your answer.

.....
.....
.....[2]

- (iii) Suggest **one** change the student could make, other than using a catalyst, to increase the rate of this reaction.

.....
.....[1]

6 Fig. 6.1 shows an electric train.

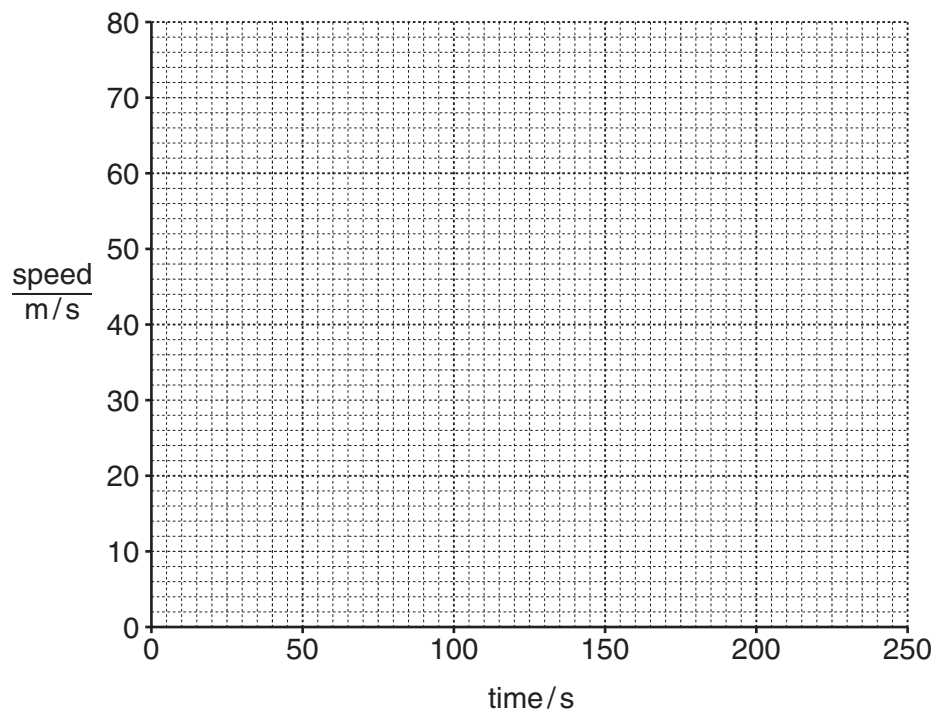

Fig. 6.1

The train starts from rest and accelerates with constant acceleration. The train reaches 45 m/s after 60 seconds.

The train then continues at this constant speed for 150 seconds.

(a) (i) On the grid below sketch a speed/time graph for the train.



[2]

- (ii) Calculate the distance travelled by the train between 60 seconds and 210 seconds.

Show your working.

distance =m [2]

- (b) The train track is made from lengths of steel rail. The steel rails are made from steel blocks.

Each rail is made using 512000cm^3 of steel.

The density of steel is 8.0g/cm^3 .

Calculate the mass of a steel rail.

State the formula you use and show your working.

formula

working

mass =g [2]

(c) Fig. 6.2 shows the two horizontal forces acting on the train when it is moving.

Force **D** is the driving force from the engine. Force **F** is the frictional force from air resistance and the wheels.

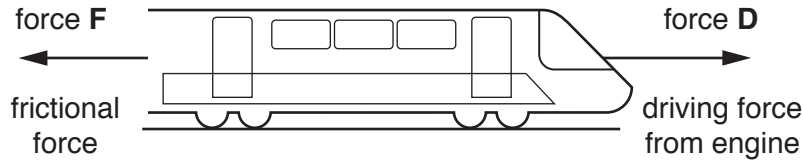

Fig. 6.2

State what can be said about the two forces **D** and **F** acting on the train when the train is accelerating,

.....

travelling at a constant speed.

.....

[2]

(d) The power station that supplies the electrical energy for the overhead cables on the railway uses natural gas as its energy source.

(i) Describe the processes and energy transfers involved in generating electrical energy from natural gas.

processes

.....

energy transfers

.....

[4]

(ii) Natural gas is a non-renewable energy source.

Name **one** other non-renewable energy source and **one** renewable energy source.

non-renewable source

renewable source

[1]

Please turn over for Question 7.

7 (a) Use the terms in the list to complete the sentences about homeostasis.

Each term may be used once, more than once, or not at all.

- arterioles capillaries environment shiver sweat
 temperature vasoconstriction vasodilation veins

Homeostasis is defined as the maintenance of a constant internal

If a person's body temperature gets too low, the person may
 to raise their temperature again. Also, in the skin, may
 undergo, reducing the blood flow to the near
 the skin surface.

[5]

(b) Fig. 7.1 shows how a person's body temperature changes over a period of three hours.

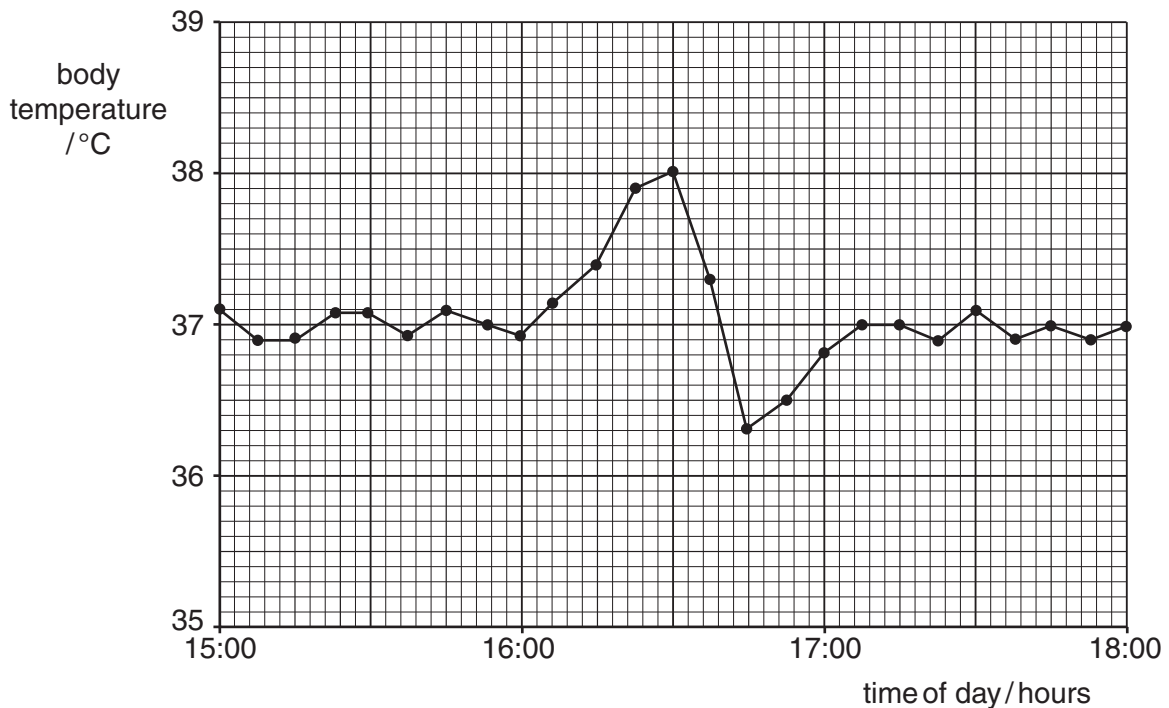

Fig. 7.1

(i) State the time at which the person's body temperature is highest.

.....

[1]

(ii) During the three hour period, the external environment stays the same.

Suggest why the person's body temperature

starts to rise at 16:00 hours,

.....

falls again after that.

.....

[2]

(iii) Describe the role of fatty tissue in the skin in the control of body temperature.

.....

.....

.....[2]

- 8 (a) Fig. 8.1 shows sodium burning in chlorine gas.

The product of this reaction is a white solid compound.

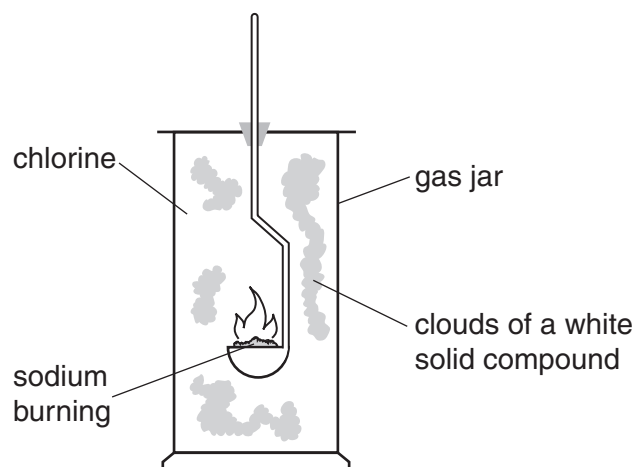

Fig. 8.1

- (i) Write the **word** equation for the reaction shown in Fig. 8.1.

..... [2]

- (ii) Fig. 8.2 shows some of the particles that are bonded together in the white solid.

These particles have electrical charges as shown.

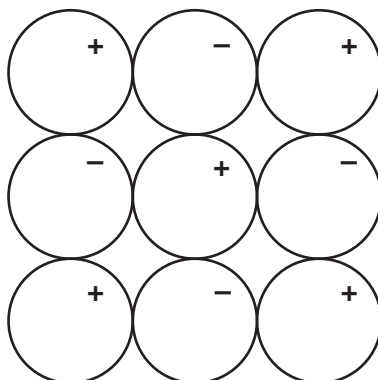

Fig. 8.2

Add the chemical symbols for the metal, Na, and non-metal, Cl, to the particles in Fig. 8.2. [1]

- (iii) Describe, in terms of electrons, how a chlorine atom becomes a chloride ion.

.....
 [1]

(b) A student was asked to produce some chlorine.

Fig. 8.3 shows the apparatus and most of the materials that he was given to complete the task.

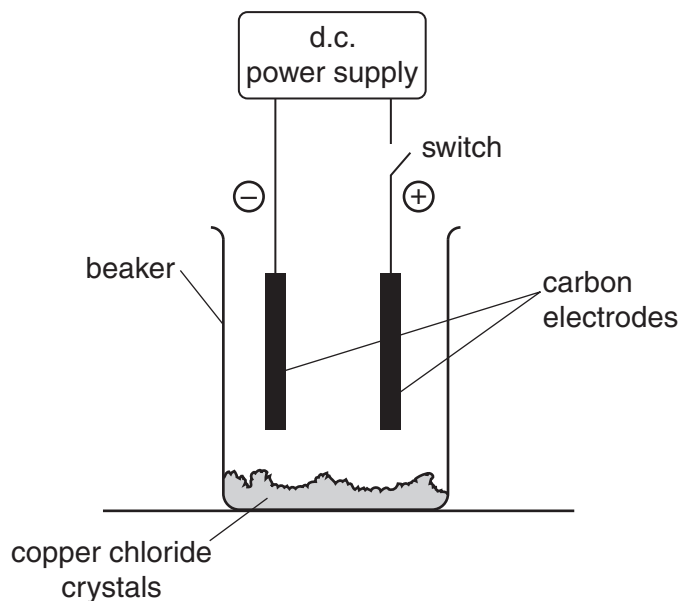

Fig. 8.3

(i) Describe how the student should use the apparatus and materials to produce chlorine. Include in your answer any other materials that are required.

.....

.....

.....

.....

.....

.....[3]

(ii) Describe how the appearance of the carbon cathode changes during the electrolysis of copper chloride.

Explain your answer.

change in appearance

.....

explanation

.....

[2]

(c) The bell in Fig. 8.4 is made from a mixture of copper and tin.

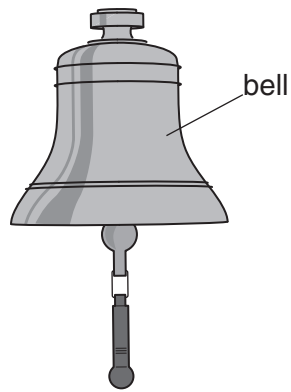

Fig. 8.4

(i) State the word that is used for a mixture of metals.

..... [1]

(ii) The metal used to make the bell is less malleable than pure copper and pure tin.

State the meaning of the term *malleable*.

.....
..... [1]

(iii) Suggest an advantage of making the bell from a metal that is **not** malleable.

.....
..... [1]

9 (a) A nuclear power station uses the energy from nuclear fission to generate electricity.

(i) Describe what happens to the nucleus of an atom when it undergoes nuclear fission.

.....
.....[1]

(ii) Place alpha (α), beta (β) and gamma (γ) radiations in order of their ionising ability.

most ionising least ionising [1]

(iii) Alpha radiation sources are more dangerous to humans, when they are breathed in or swallowed, than alpha radiation sources remaining outside the body.

Explain this observation.

.....
.....[1]

(b) An overhead power cable transmits electrical power from a power station to a town.

The resistance of the cable is $6\ \Omega$.

(i) State the effect on the resistance of the cable if the diameter of the cable is increased.

.....[1]

(ii) State **one** way to change the resistance of the cable, other than changing the diameter.

.....
.....[1]

10 (a) Fig. 10.1 shows the human female reproductive system.

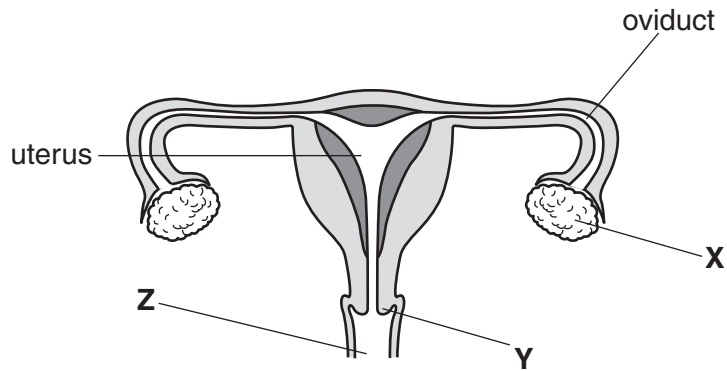

Fig. 10.1

(i) Name the parts labelled X, Y and Z.

X

Y

Z

[3]

(ii) State **one** function of part X.

.....[1]

(b) (i) State where in the female reproductive system the egg is fertilised.

.....[1]

(ii) Outline the early development of the zygote after fertilisation.

.....

[3]

11 Fig. 11.1 shows apparatus used to investigate the compounds produced when ethanol burns.

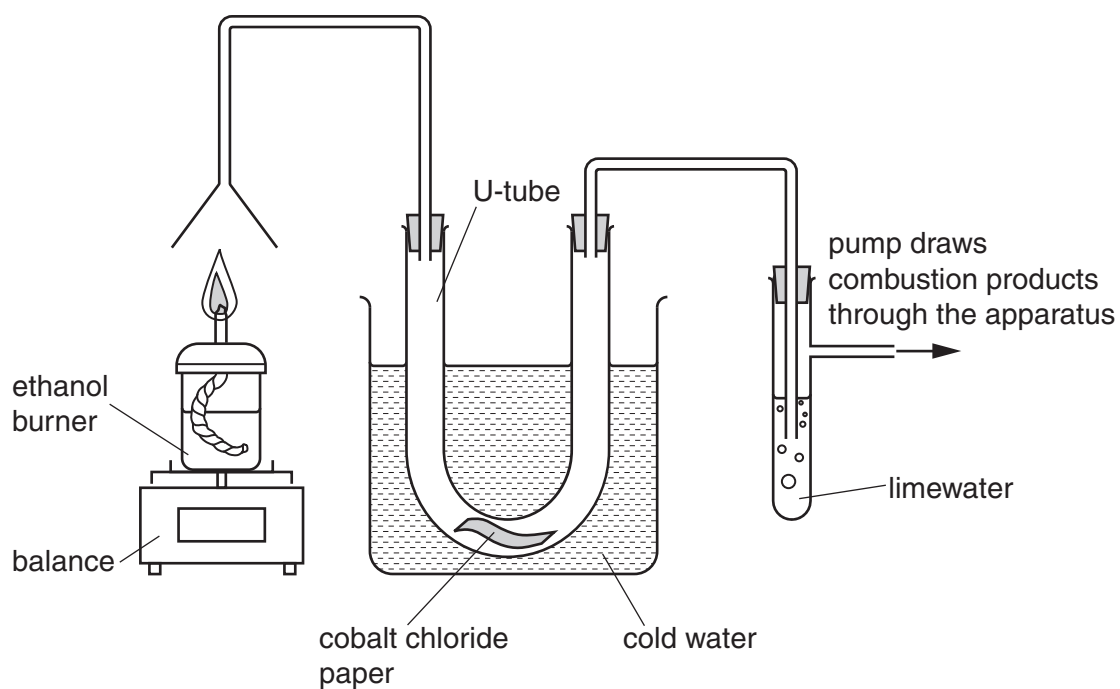

Fig. 11.1

- (a) (i) Before the ethanol burner is lit, the cobalt chloride paper is blue and the limewater is colourless.

Predict and explain the changes in appearance of the cobalt chloride paper and the limewater shortly after the burner is lit.

cobalt chloride paper

explanation

limewater

explanation

[4]

- (ii) Predict what happens to the reading on the balance during the experiment.

.....[1]

(b) Fig. 11.2 shows diagrams of molecules, **I**, **J** and **K**.

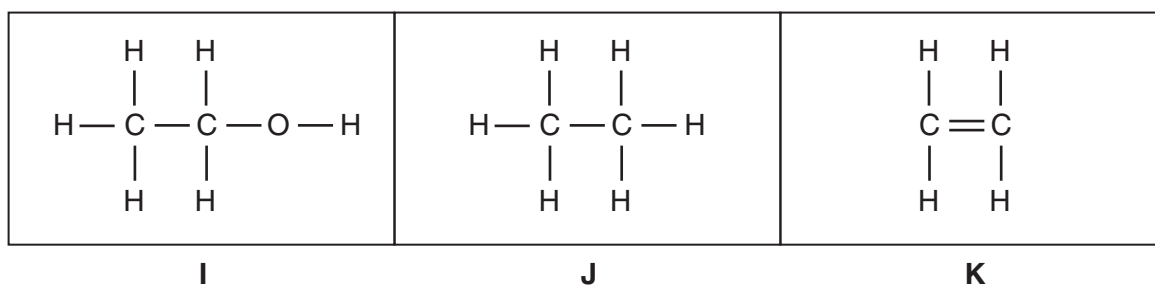

Fig. 11.2

(i) Molecule **J** is a saturated hydrocarbon.

State what is meant by the terms

hydrocarbon,

.....

saturated.

.....

[2]

(ii) Name molecules **I** and **K**.

I

K

[2]

(iii) State the chemical formula of the molecule that reacts with molecule **K** to form molecule **I**.

.....

[1]

12 (a) A star emits γ -rays and visible light.

γ -rays and visible light are parts of the electromagnetic spectrum.

Place γ -rays and visible light in their correct positions in the incomplete electromagnetic spectrum shown in Fig. 12.1. [1]

	X-rays			infra-red waves	microwaves	
--	--------	--	--	-----------------	------------	--

Fig. 12.1

(b) Below are four terms used to describe a wave. Draw a line from each term to its definition.

term	definition
amplitude	how far the wave travels in one second
frequency	the distance from any point on one wave to the same point on the next wave
speed	the distance from the centre of a wave to the top or to the bottom of the wave
wavelength	the number of waves passing a fixed point in one second

[2]

(c) Telescopes used to observe stars contain mirrors.

Fig. 12.2 shows a ray of light reflecting from a plane mirror.

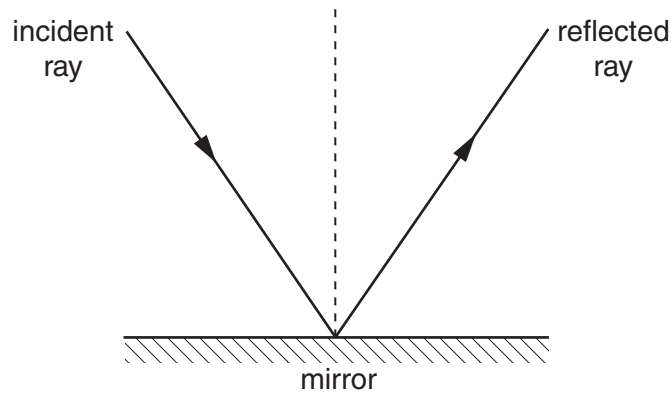

Fig. 12.2

(i) On Fig. 12.2 label with an r the angle of reflection. [1]

(ii) The angle of incidence is 36° .

State the angle of reflection. Explain your answer.

angle of reflection

explanation

.....

[1]

(d) Fig. 12.3 shows a comet seen in the sky by an astronomer.



Fig. 12.3

The astronomer observes the comet in a mirror.

Draw an image of the comet that the astronomer sees in the mirror.

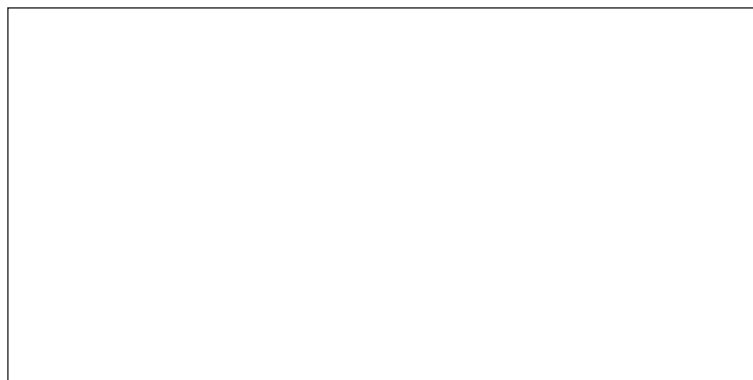

[1]

(e) Telescopes also contain lenses.

Rays of light from a star pass through a lens, as shown in Fig. 12.4.

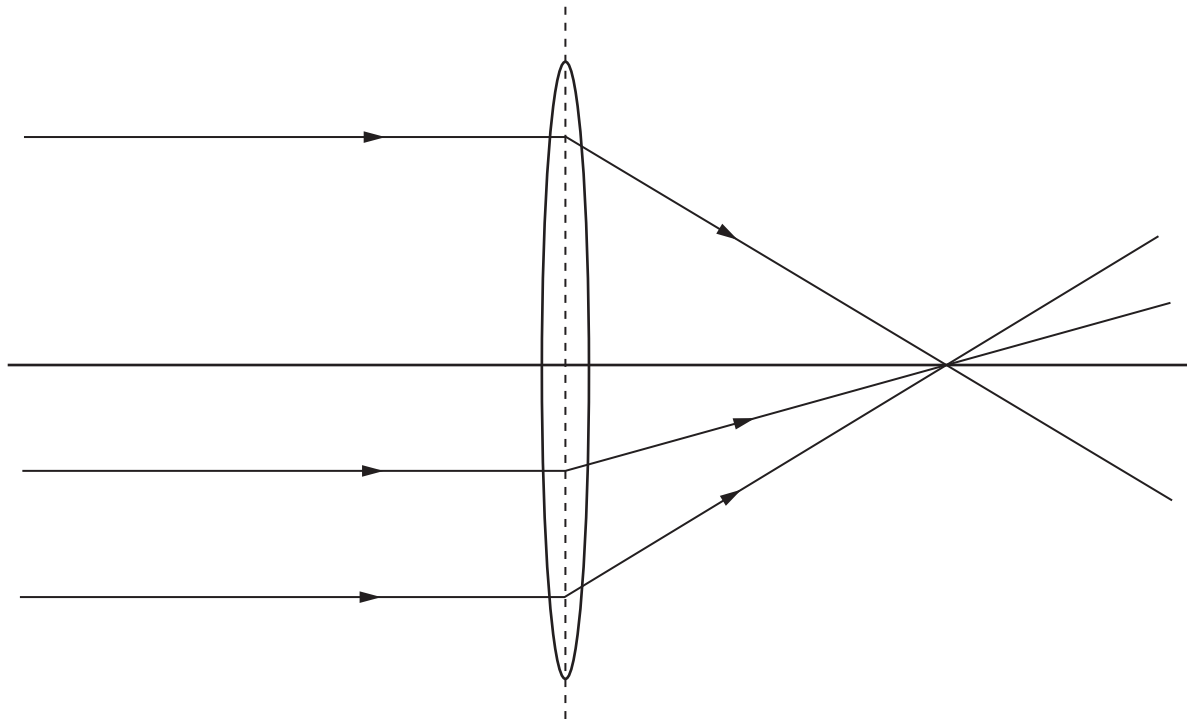

Fig. 12.4

- (i) On Fig. 12.4, label the principal focus of the lens with the letter **P**. [1]
 - (ii) On Fig. 12.4, use a double-headed arrow (\leftrightarrow) to indicate the focal length of the lens. [1]
 - (iii) As light passes through the lens, the direction of the light is changed. State the name of this process. [1]
-

(f) An explosion in space produces both light waves and sound waves.

- (i) Explain why an astronomer on Earth would be able to see the light wave through a telescope but would not be able to hear the sound wave produced by the explosion. [1]
-
-
-[1]
- (ii) State **one** other difference between a light wave and a sound wave. [1]
-
-[1]

The Periodic Table of Elements

Group																		
I	II											III	IV	V	VI	VII	VIII	
		Key atomic number atomic symbol name relative atomic mass										1 H hydrogen 1						2 He helium 4
3 Li lithium 7	4 Be beryllium 9											5 B boron 11	6 C carbon 12	7 N nitrogen 14	8 O oxygen 16	9 F fluorine 19	10 Ne neon 20	
11 Na sodium 23	12 Mg magnesium 24											13 Al aluminium 27	14 Si silicon 28	15 P phosphorus 31	16 S sulfur 32	17 Cl chlorine 35.5	18 Ar argon 40	
19 K potassium 39	20 Ca calcium 40	21 Sc scandium 45	22 Ti titanium 48	23 V vanadium 51	24 Cr chromium 52	25 Mn manganese 55	26 Fe iron 56	27 Co cobalt 59	28 Ni nickel 59	29 Cu copper 64	30 Zn zinc 65	31 Ga gallium 70	32 Ge germanium 73	33 As arsenic 75	34 Se selenium 79	35 Br bromine 80	36 Kr krypton 84	
37 Rb rubidium 85	38 Sr strontium 88	39 Y yttrium 89	40 Zr zirconium 91	41 Nb niobium 93	42 Mo molybdenum 96	43 Tc technetium –	44 Ru ruthenium 101	45 Rh rhodium 103	46 Pd palladium 106	47 Ag silver 108	48 Cd cadmium 112	49 In indium 115	50 Sn tin 119	51 Sb antimony 122	52 Te tellurium 128	53 I iodine 127	54 Xe xenon 131	
55 Cs caesium 133	56 Ba barium 137	57–71 lanthanoids	72 Hf hafnium 178	73 Ta tantalum 181	74 W tungsten 184	75 Re rhenium 186	76 Os osmium 190	77 Ir iridium 192	78 Pt platinum 195	79 Au gold 197	80 Hg mercury 201	81 Tl thallium 204	82 Pb lead 207	83 Bi bismuth 209	84 Po polonium –	85 At astatine –	86 Rn radon –	
87 Fr francium –	88 Ra radium –	89–103 actinoids	104 Rf rutherfordium –	105 Db dubnium –	106 Sg seaborgium –	107 Bh bohrium –	108 Hs hassium –	109 Mt meitnerium –	110 Ds darmstadtium –	111 Rg roentgenium –	112 Cn copernicium –	114 Fl flerovium –		116 Lv livermorium –				

lanthanoids	57 La lanthanum 139	58 Ce cerium 140	59 Pr praseodymium 141	60 Nd neodymium 144	61 Pm promethium –	62 Sm samarium 150	63 Eu europium 152	64 Gd gadolinium 157	65 Tb terbium 159	66 Dy dysprosium 163	67 Ho holmium 165	68 Er erbium 167	69 Tm thulium 169	70 Yb ytterbium 173	71 Lu lutetium 175
actinoids	89 Ac actinium –	90 Th thorium 232	91 Pa protactinium 231	92 U uranium 238	93 Np neptunium –	94 Pu plutonium –	95 Am americium –	96 Cm curium –	97 Bk berkelium –	98 Cf californium –	99 Es einsteinium –	100 Fm fermium –	101 Md mendelevium –	102 No nobelium –	103 Lr lawrencium –

The volume of one mole of any gas is 24 dm³ at room temperature and pressure (r.t.p.)