



UNIVERSITY OF CAMBRIDGE INTERNATIONAL EXAMINATIONS
International General Certificate of Secondary Education

CANDIDATE NAME

CENTRE NUMBER

CANDIDATE NUMBER

* 8 6 1 8 2 0 5 9 0 4 *

CO-ORDINATED SCIENCES **0654/53**
Paper 5 Practical Test **October/November 2012**
2 hours

Candidates answer on the Question Paper.
Additional Materials: As listed in Instructions to Supervisors

READ THESE INSTRUCTIONS FIRST

Write your Centre number, candidate number and name on all the work you hand in.
Write in dark blue or black pen.
You may use a pencil for any diagrams, graphs or rough working.
Do not use staples, paper clips, highlighters, glue or correction fluid.
DO NOT WRITE IN ANY BARCODES.

Answer **all** questions.
Chemistry practical notes for this paper are printed on page 12.

At the end of the examination, fasten all your work securely together.
The number of marks is given in brackets [] at the end of each question or part question.

For Examiner's Use	
1	
2	
3	
Total	

This document consists of **11** printed pages and **1** blank page.

1 You are supplied with two containers, **A** and **B**, containing leaves of two different species. You are going to investigate some of the properties of these leaves.

(a) There is air inside leaves. If a leaf is placed in hot water, this air expands so that some air escapes from the leaf.

(i) Follow the procedure below.

- Half-fill a beaker with water and use a Bunsen burner to bring it almost to the boil (80–100 °C).
- Once the water is hot enough, turn off the Bunsen burner.
- Using tweezers, take a leaf from dish **A**.
- Hold the leaf by the base and plunge it into the water.
- Keep the leaf under the water for 5–10 seconds, while watching its **lower surface**. You are looking for signs of air escaping from the leaf.
- Record your observations in Table 1.1.
- Repeat the process with another leaf from dish **A**, but this time concentrate on watching the **upper surface** of the leaf.
- Record your observations in Table 1.1.
- Repeat the above procedure on the two surfaces of leaves from dish **B** and record your observations in Table 1.1.

Table 1.1

leaves from dish A		leaves from dish B	
lower surface	upper surface	lower surface	upper surface

[3]

(ii) The main function of the leaves of a plant is to carry out photosynthesis. Explain how air inside the leaves helps with this function.

.....
 [1]

(iii) Name the structures in the surface of the leaf from which most of the air escapes.

..... [1]

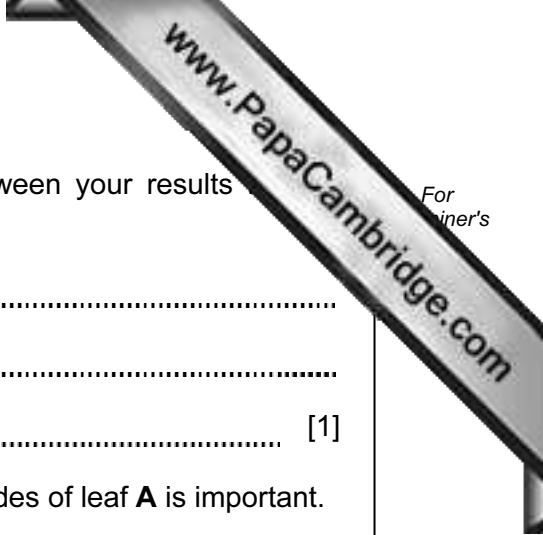

(iv) Explain, in terms of leaf structure, the differences between your results upper and lower surfaces of the leaf from dish **A**.

.....
.....
..... [1]

(v) Suggest why the structural difference between the two sides of leaf **A** is important.

.....
.....
..... [2]

(vi) Compare the results you obtained from leaves **A** and **B**, and suggest a reason for any differences.

.....
.....
..... [1]

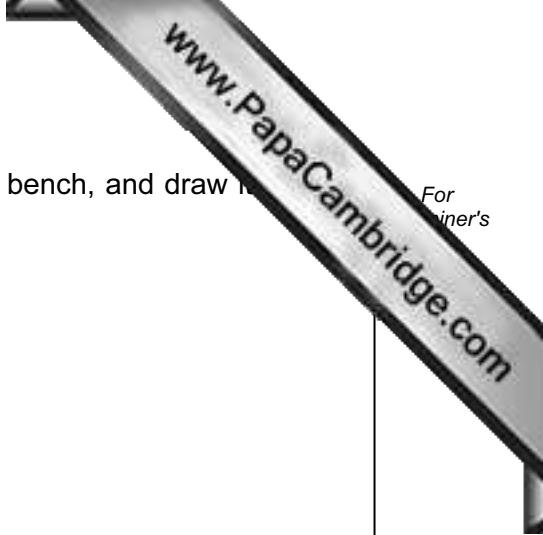

(b) (i) Take another leaf from dish **A**. Place the leaf flat on the bench, and draw it in the space below.

[2]

(ii) Measure the maximum width of

the original leaf, mm

your drawing of this leaf. mm

[1]

(iii) From your measurements in (b)(ii), calculate the magnification of your drawing.

magnification [1]

(iv) Explain **two visible** features of this leaf that help it to photosynthesise efficiently.

1
.....

2
..... [2]

- 2 (a) In this experiment you will be investigating the effect of a force acting at different angles.

Set up two smooth rods or pulleys 20 cm apart and at the same horizontal level at least 30 cm above the bench.

Attach 50 g masses to both ends of a piece of thread so that when the thread is placed over the two smooth rods or pulleys, the masses are clear of the bench. See Fig. 2.1.

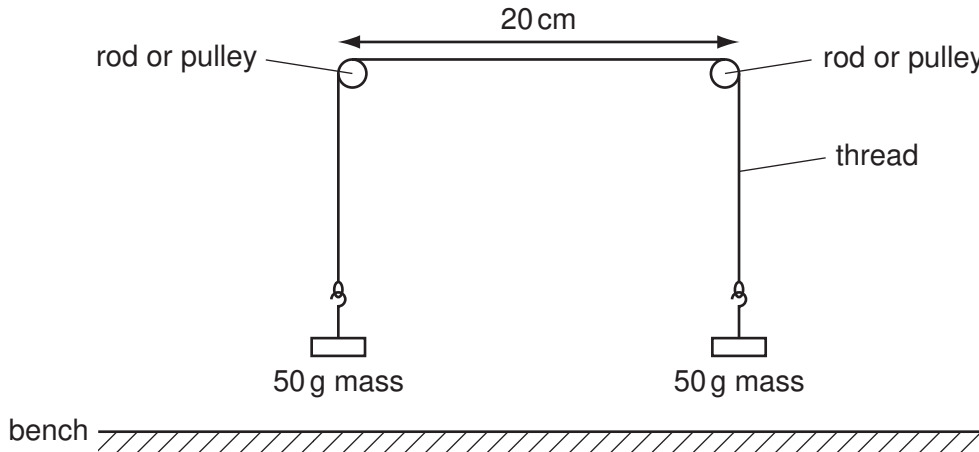

Fig. 2.1

- (i)
- Hang a 10 g mass, m , from a point **halfway** between the smooth rods or pulleys, ensuring that the thread moves smoothly over the rods.
 - Allow the mass to drop freely; do not pull it down.
 - Hold the protractor sheet behind the apparatus and adjust the position of the sheet so that the angle, θ , as shown in Fig. 2.2, is the same on both sides.
 - Measure angle, θ , and enter the value in column 2 of Table 2.1 on page 6. [1]

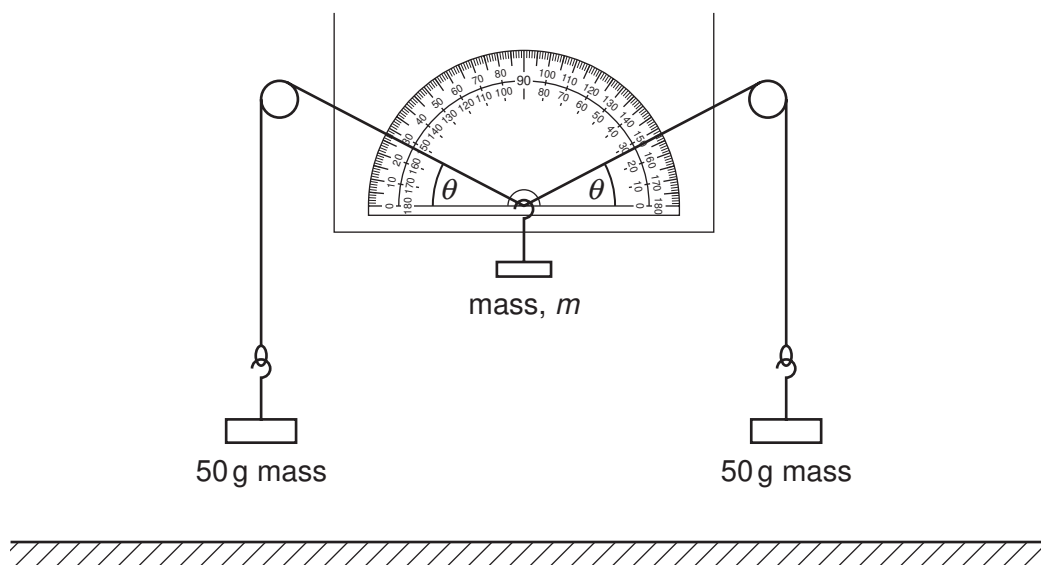

Fig. 2.2

Table 2.1

mass, m/g	angle $\theta/^\circ$	sine θ
0	0	0.00
10		
20		
40		
60		
80		

- (ii)
- Remove the 10 g mass, m .
 - Repeat (a)(i) for mass, m , equal to 20 g, 40 g, 60 g, and 80 g.
 - Measure and record the values of angle, θ , in column 2 of Table 2.1. [5]

Note that the value for θ when no mass is hung from the middle of the thread has been entered in Table 2.1 for you.

- (iii) Using the values in Table 2.2, or by using a calculator, find the sine of the angle, θ , for each mass used and enter the values in column 3 of Table 2.1. [1]

Table 2.2

angle $\theta/^\circ$	sine θ	angle $\theta/^\circ$	sine θ	angle $\theta/^\circ$	sine θ
0	0.00	35	0.57	70	0.94
5	0.09	40	0.64	75	0.97
10	0.17	45	0.71	80	0.98
15	0.26	50	0.77	85	1.00
20	0.34	55	0.82	90	1.00
25	0.42	60	0.87		
30	0.50	65	0.91		

- (b) (i) Plot a graph of $\sin \theta$ (vertical axis) against mass, m on the grid provided. The vertical scale should go to 1.0 and the horizontal scale should go to 120g.

Draw the best straight line.

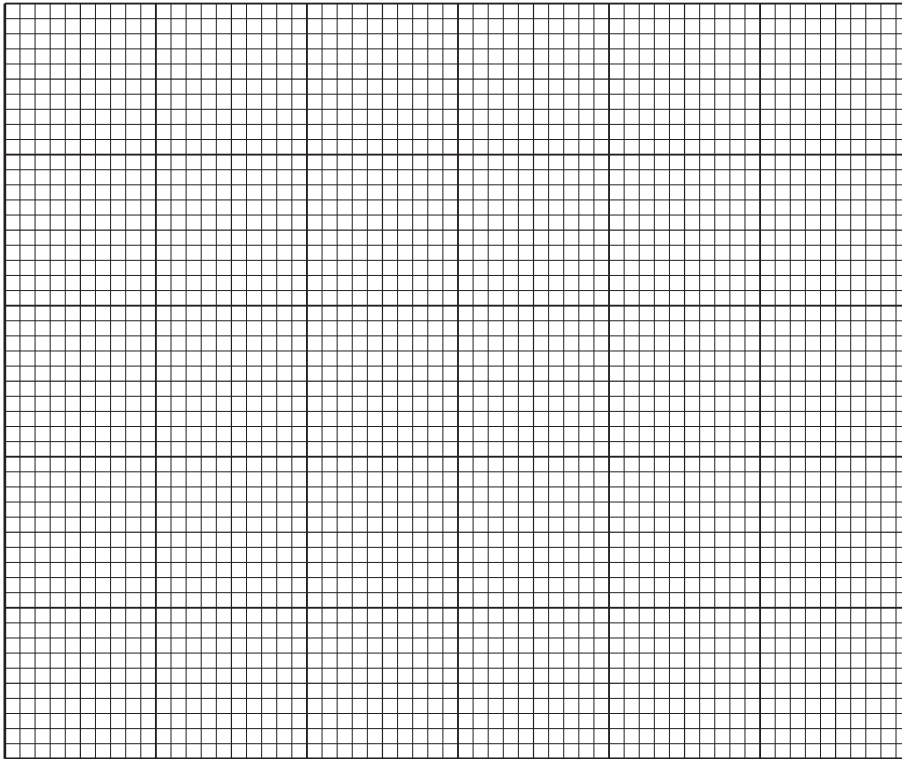

[5]

- (ii) Extend the line you have drawn so that it reaches a $\sin \theta$ value of 1.0.

Read the value of mass, m , which corresponds with the $\sin \theta$ value of 1.0.

$m = \dots\dots\dots$ g [2]

- (iii) In theory the value of the mass, m , in (b)(ii) should equal the sum of the two masses on the ends of the thread (100g).

In practice it is rarely equal to the sum of the two masses.

Suggest another force which could cause the difference.

.....
..... [1]

- 3 **Solid A** is an element. **Solution B** is an aqueous solution of a compound containing one cation and one anion.

Carry out the following experiments to identify **A** and **B**.

- (a) (i) Place a small spatula load of solid **A** in a test-tube and add about a half test-tube of dilute hydrochloric acid.

Keep your finger on the mouth of the test-tube for one minute. Test any gas produced with a lighted splint.

Record your observations.

.....
..... [2]

- (ii) Name the gas produced in this reaction.

name of gas is [1]

- (iii) Suggest a possible identity for **A**.

A is [1]

- (b) (i) Place about 2 cm³ solution **B** in a test-tube and add about 5 cm³ aqueous sodium hydroxide.

Record your observations.

.....
..... [1]

- (ii) Suggest the identity of the cation in **B**.

cation in **B** is [1]

- (c) (i) One-third fill (about 20 cm³) a large test-tube with solution **B** and add the remainder of solid **A**. Stopper the tube and shake gently from side to side for two minutes. Allow any solid to settle.

Keep the contents of the tube for (c)(ii).

Record your observations.

.....
..... [1]

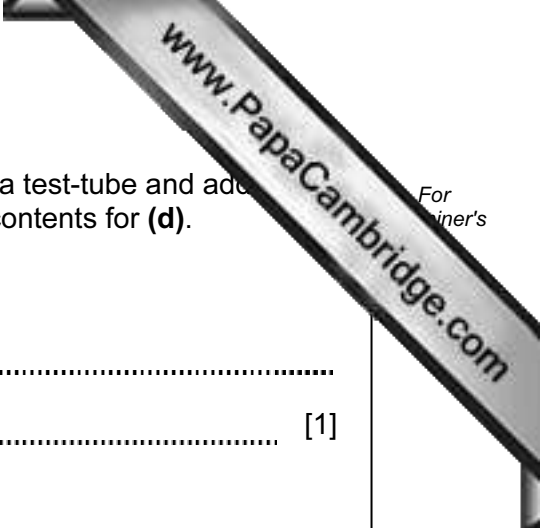

- (ii) Carefully pour off about 2 cm³ of the liquid from (c)(i) into a test-tube and add 5 cm³ aqueous sodium hydroxide. Keep the tube and its contents for (d).

Record your observations.

.....
..... [1]

- (iii) Suggest the identity of the cation in the mixture in (c)(ii).

cation in mixture is [1]

- (d) Stopper the tube from (c)(ii) and with a finger firmly on the stopper, shake vigorously for one minute.

Record your observations.

.....
..... [1]

- (e) Using the results from (b), (c) and (d), suggest what solid A has done to the cation in solution B.

.....
..... [1]

- (f) (i) To about 2 cm³ solution B add an equal volume of aqueous barium chloride.

Record your observations.

.....
..... [1]

- (ii) What can you conclude from the results of this test?

.....
..... [1]

(g) (i) To about 2 cm³ solution **B** add an equal volume of aqueous silver nitrate.

Record your observations.

.....
..... [1]

(ii) Name the anion in solution **B**.

anion in **B** is [1]

CHEMISTRY PRACTICAL NOTES

Test for anions

<i>anion</i>	<i>test</i>	<i>test result</i>
carbonate (CO_3^{2-})	add dilute acid	effervescence, carbon dioxide produced
chloride (Cl^-) [in solution]	acidify with dilute nitric acid, then add aqueous silver nitrate	white ppt.
nitrate (NO_3^-) [in solution]	add aqueous sodium hydroxide then aluminium foil; warm carefully	ammonia produced
sulfate (SO_4^{2-}) [in solution]	acidify then add aqueous barium chloride <i>or</i> aqueous barium nitrate	white ppt.

Test for aqueous cations

<i>cation</i>	<i>effect of aqueous sodium hydroxide</i>	<i>effect of aqueous ammonia</i>
ammonium (NH_4^+)	ammonia produced on warming	-
copper(II) (Cu^{2+})	light blue ppt., insoluble in excess	light blue ppt., soluble in excess giving a dark blue solution
iron(II) (Fe^{2+})	green ppt., insoluble in excess	green ppt., insoluble in excess
iron(III) (Fe^{3+})	red-brown ppt., insoluble in excess	red-brown ppt., insoluble in excess
zinc (Zn^{2+})	white ppt., soluble in excess giving a colourless solution	white ppt., soluble in excess giving a colourless solution

Test for gases

<i>gas</i>	<i>test and test results</i>
ammonia (NH_3)	turns damp red litmus paper blue
carbon dioxide (CO_2)	turns limewater milky
chlorine (Cl_2)	bleaches damp litmus paper
hydrogen (H_2)	"pops" with a lighted splint
oxygen (O_2)	relights a glowing splint