



UNIVERSITY OF CAMBRIDGE INTERNATIONAL EXAMINATIONS
International General Certificate of Secondary Education

CANDIDATE NAME

CENTRE NUMBER

CANDIDATE NUMBER

* 4 6 1 7 4 5 8 2 2 6 *

CO-ORDINATED SCIENCES

0654/61

Paper 6 Alternative to Practical

October/November 2010

1 hour

Candidates answer on the Question paper

No Additional Materials are required.

READ THESE INSTRUCTIONS FIRST

Write your Centre number, candidate number and name on all the work you hand in.

Write in dark blue or black pen.

You may use a soft pencil for any diagrams, graphs, tables or rough working.

Do not use staples, paper clips, highlighters, glue or correction fluid.

DO NOT WRITE IN ANY BARCODES.

Answer **all** questions.

At the end of the examination, fasten all your work securely together.

The number of marks is given in brackets [] at the end of each question or part question.

For Examiner's Use	
1	
2	
3	
4	
5	
6	
Total	

This document consists of **15** printed pages and **1** blank page.



- 1 (a) A student did an experiment to investigate the effect of light on the mass of seeds during germination and early growth of seedlings.

She used two batches of 10 seeds. Batch **A** was left in daylight. Batch **B** was kept in the dark throughout the experiment. Both batches were supplied with water.

She measured the mass of the two batches before the experiment, and then at intervals for one week. By this time both batches of seedlings had produced leaves. The seedlings that were grown in the dark were about twice as tall as those grown in the light.

Read the balance windows in Fig. 1.1. These show the initial masses of the seeds.

Enter the readings in Table 1.2.

[2]



Fig. 1.1

Table 1.2

time in days	batch A		batch B	
	mass of 10 seeds/g	average mass of one seed/g	mass of 10 seeds/g	average mass of one seed/g
0				
1	17.4		16.8	
4	25.7		32.2	
7	32.6		42.0	

- (b) The results of the experiment are shown in Table 1.2.

Calculate the average masses and complete Table 1.2.

[2]

(c) On the grid below, draw a graph of **average mass of one seed** against **time** for **batch A**.

On the same axes draw the same graph for batch **B**.

average
mass of
seed / g

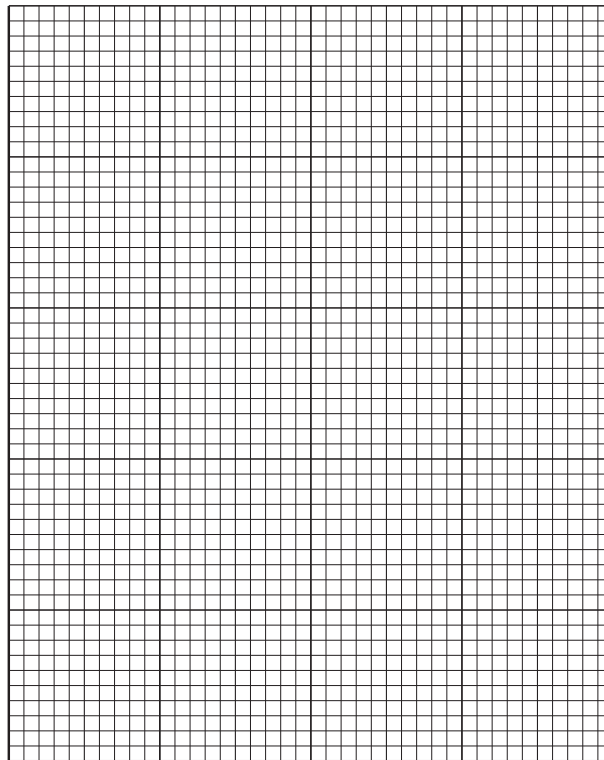

time / days

[3]

(d) (i) Explain why the seedlings in the dark were able to increase in mass even though they could not carry out photosynthesis.

.....
..... [1]

(ii) Suggest what will happen to the seedlings kept in the dark after a few weeks, and explain your answer.

.....
.....
..... [2]

- 2 A student wrote the following statement:
“When two lamps are connected in series, the total power output is half of the power output of a single lamp.”

He tested this statement by doing two experiments shown in Fig. 2.1 and Fig. 2.2.

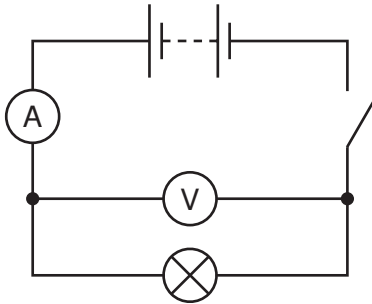

Fig. 2.1

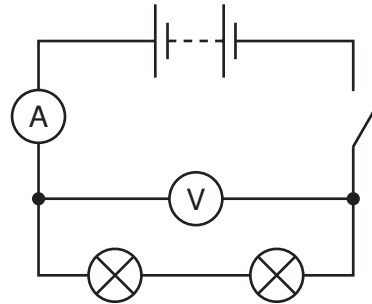

Fig. 2.2

- He connected up the circuit shown in Fig. 2.1.
- He closed the switch and read the ammeter and voltmeter, then recorded the readings in Table 2.3.
- He added another lamp, the same as the first lamp, as shown in Fig. 2.2.
- He closed the switch, read the ammeter and voltmeter again and recorded the readings in Table 2.3.

Table 2.3

	current / A	voltage / V	power output, equal to current x voltage
single lamp	0.25		
two lamps	0.12		

- (a) (i) Fig. 2.4 shows the voltmeters for the circuits in Fig. 2.1 and Fig. 2.2. Read the voltages and record them in Table 2.3. [2]

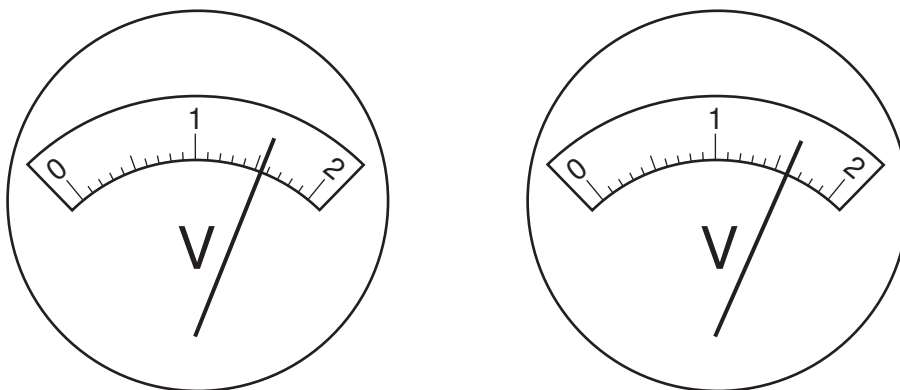

Fig. 2.4

- (ii) Find the value of the power for each circuit by multiplying the current by the voltage. Record the values in Table 2.3. [2]
- (iii) What is the unit of power for these values?

..... [1]

Another student wrote the following statement.

“When two lamps are connected in parallel, the total power output is double that of a single lamp.”

For
Trainer's

He altered the circuit shown in Fig. 2.2 so that the two lamps were in parallel.

(b) (i) Complete the circuit shown in Fig. 2.5 by drawing two lamps in parallel.

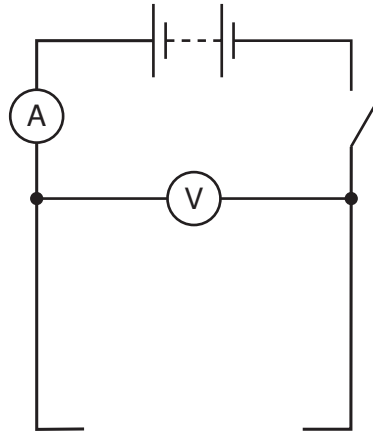

Fig. 2.5

[1]

(ii) Fig. 2.6 shows the ammeter in the circuit, Fig. 2.5.

[1]

Record the reading in Table 2.7.

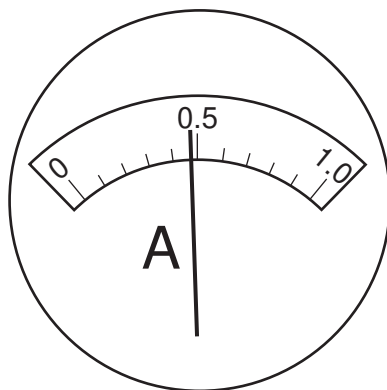

Fig. 2.6

Table 2.7

ammeter reading / A	voltmeter reading / V	power output, equal to current x voltage
	1.5	

(iii) Complete Table 2.7 by calculating the power output of the lamps.

[1]

(c) Compare the data in Table 2.3 and Table 2.7. Comment on the **two** statements made by the students.

.....
..... [1]

(d) What other piece of apparatus must be used in an experiment to find the total energy used by the lamps in a circuit?

..... [1]

- 3 The science teacher gives a student a sample of compound **X**. It is a light green crystalline solid. The student carries out the experiments shown in Table 3.1 to find out what compound **X** contains.

Complete Table 3.1.

Table 3.1

test	observations	conclusions
(a) Add compound X to aqueous sodium hydroxide and warm the mixture.	A strong smelling gas is given off. The gas turns litmus [1]	The gas is [1] Compound X contains [1] ions.
(b) Dissolve compound X in water. Divide the resulting solution X into three parts.		
(i) To the first part of solution X , add aqueous sodium hydroxide.	There is a green precipitate which turns brown after standing in air for a few minutes.	The precipitate is [1] hydroxide. This turns to [1] hydroxide by a process known as [1]
(ii) To the second part of solution X , add dilute hydrochloric acid followed by aqueous [1] [1]	Compound X contains sulfate ions.
(iii) To the third part of solution X , add dilute acid followed by aqueous [2]	No precipitate is formed.	Compound X does not contain chloride ions.

- 4 A science student visits a café and notices that a drink is heated by passing steam. He decides to do an experiment in the laboratory to find out how steam can heat up water. The apparatus is shown in Fig. 4.1.

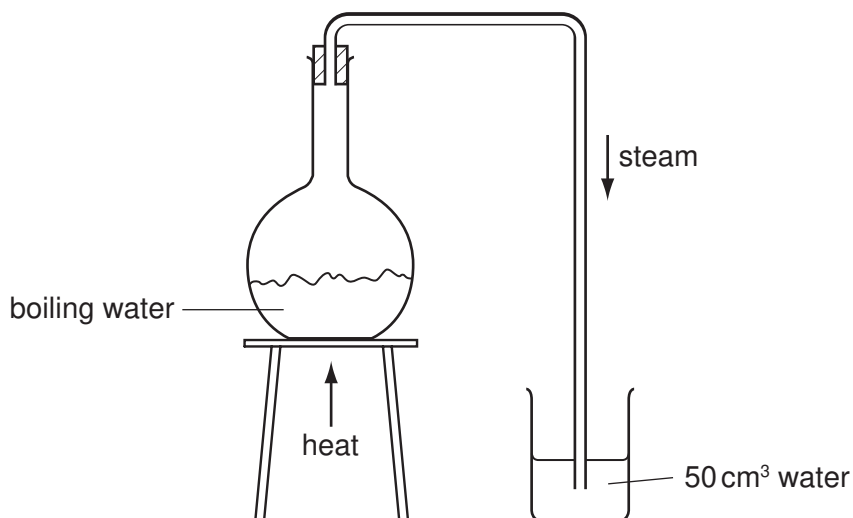

Fig. 4.1

- He places 50 cm³ of water in a beaker.
- He weighs the beaker containing the water, mass m_1 .
- He finds the temperature of the water, temperature t_1 .
- He passes steam into the water for a few minutes.
- He finds the temperature, t_2 , of the water after passing the steam.
- He weighs the beaker and water again, mass m_2 .

- (a) Read the thermometer scales shown in Fig. 4.2 and record the temperatures t_1 and t_2 in Table 4.4. [2]

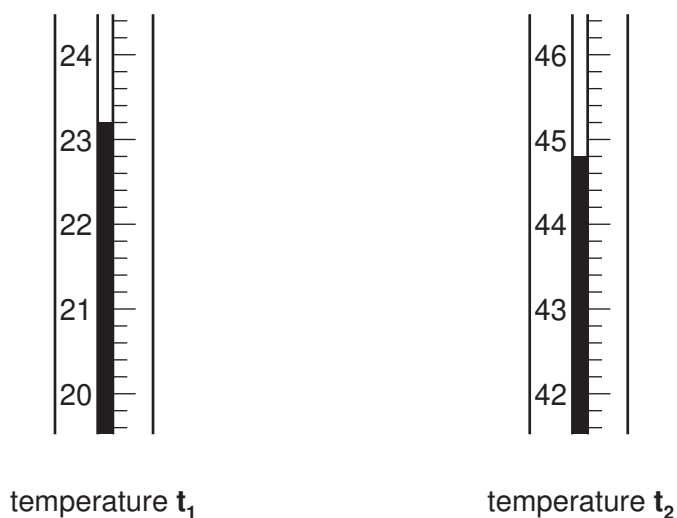

Fig. 4.2

- (b) Read the balance windows shown in Fig. 4.3 and record the masses m_1 and m_2 in Table 4.4.

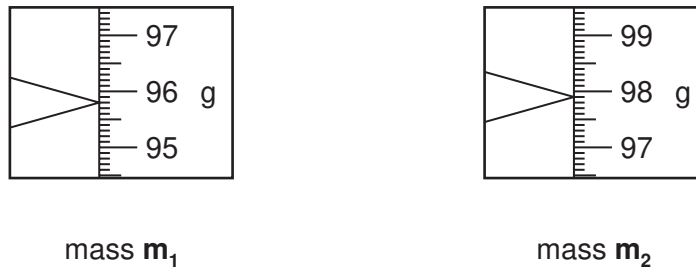

Fig. 4.3

Table 4.4

before passing steam		after passing steam	
temperature $t_1/^\circ\text{C}$		temperature $t_2/^\circ\text{C}$	
mass m_1/g		mass m_2/g	

- (c) Use data from Table 4.4 to calculate the increase in mass of the water in the beaker.

increase in mass = g [1]

- (d) Use data from Table 4.4 to calculate the increase in temperature of the water in the beaker.

increase in temperature = $^\circ\text{C}$ [1]

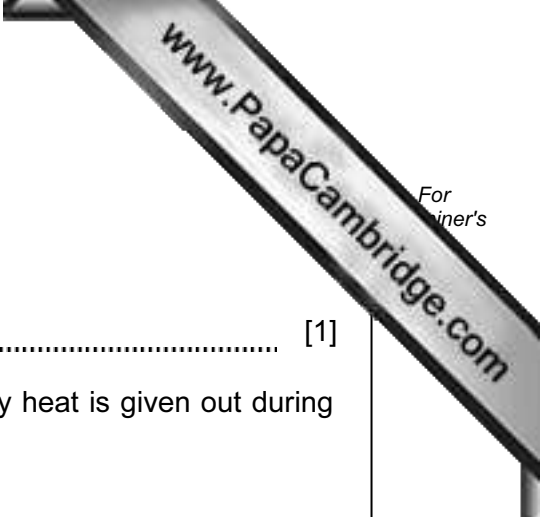

(e) (i) Name the physical change in the following process;

steam at 100 °C → water at 100 °C

..... [1]

(ii) Use your knowledge of the Kinetic Theory to explain why heat is given out during this process.

.....
.....
..... [2]

(f) The student decides that, in addition to the heat referred to in (e)(ii), some more heat was given to the water in the beaker to raise it from temperature t_1 to temperature t_2 .

Explain where this extra heat came from.

.....
..... [1]

5 This question is about the diseases kwashiorkor and diabetes, and how changes in diet can help sufferers.

(a) Kwashiorkor is caused by a lack of protein in the diet. A student was given five solutions, **A** to **E**, each of which contained either protein, starch or glucose. Two of them contained protein that may help a kwashiorkor sufferer.

She tested solutions **A** to **E** with biuret solution.

Table 5.1

solution	colour observed		
	biuret solution	iodine solution	Benedict's solution
A			blue
B			
C			
D			red
E			

In the second column of Table 5.1, record the colours she saw when the five tubes were tested with biuret solution. Solutions **C** and **E** contained protein. [2]

(b) Sufferers of diabetes are often advised to eat their carbohydrate in the form of starch rather than sugar.

The student tested the remaining solutions to find out which one contained starch by adding a few drops of iodine to fresh samples. Tube **B** produced a positive test for starch.

In the third column of Table 5.1, record the colours seen in all the tubes, tested with iodine solution. [2]

(c) There now remained **two** unidentified solutions, **A** and **D**. One of these contained the reducing sugar glucose. It is recommended that the diabetic should avoid eating large amounts of glucose.

She tested these two solutions for glucose using Benedict's solution.

The results of this test are shown in Table 5.1.

Which solution contained glucose?

Explain your answer.

..... [2]

- (d) One of the **two** protein solutions contained the enzyme amylase which catalyses the break-down of starch to sugar.

Plan an experiment to find which protein solution contained amylase.

.....

.....

.....

.....

..... [4]

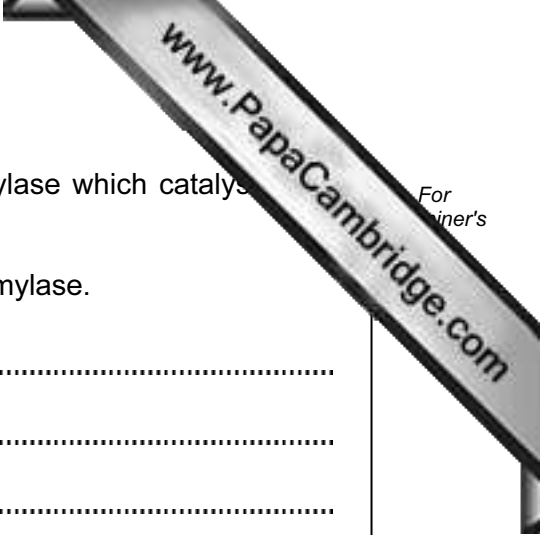

- 6 The science class is investigating the properties of the halogens chlorine, Cl_2 , bromine and iodine, I_2 . The teacher shows them samples of the three elements, shown in Fig. 6.



Fig. 6.1

- (a) State the colour of
- (i) liquid bromine,
- (ii) solid iodine. [2]
- (b) The teacher places a few cm^3 of water in the gas-jar of chlorine and quickly closes the lid. She shakes the jar to make the chlorine dissolve in the water. She pours the water out into a beaker and tests it with a piece of blue litmus paper.
- What happens to the colour of the litmus paper?
-
- [1]
- (c) The teacher places a few cm^3 of aqueous potassium iodide, KI , in a gas-jar of chlorine. The colourless liquid turns brown. Then she adds two drops of starch solution.
- (i) What is seen when the starch solution is added?
- [1]
- (ii) Write a balanced equation for the reaction between chlorine and potassium iodide.
- [2]

- (d) Fig. 6.2 shows the next experiment. The teacher places one drop of bromine in 10 cm³ of water in a beaker. She stirs the mixture to make the bromine dissolve.

She places 10 cm³ samples of the bromine water in each of three gas-jars. Each gas-jar contains one of the gases ethane, ethene and methane. She shakes the jars. The bromine water in one of the jars loses its colour.

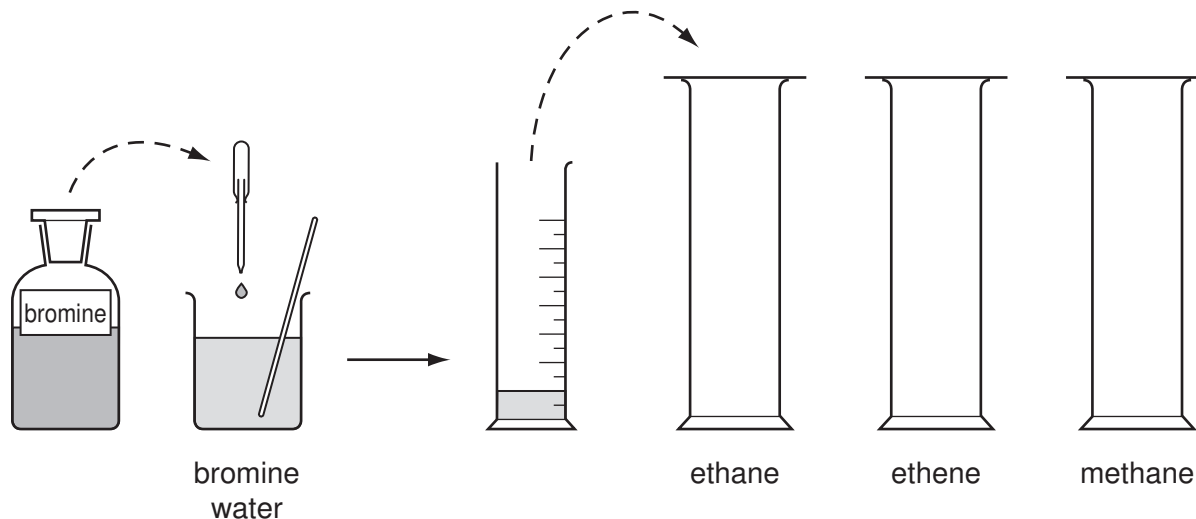

Fig. 6.2

- (i) Which gas, ethane, ethene or methane, reacts with the bromine?

..... [1]

- (ii) What does this show about the structure of the molecules of the gas that reacts?

.....
..... [1]

- (e) The teacher gives a student a crystal of iodine in a dry test-tube. She tells her to warm the test-tube using a small flame. Fig. 6.3 shows the student's diagram of the result.

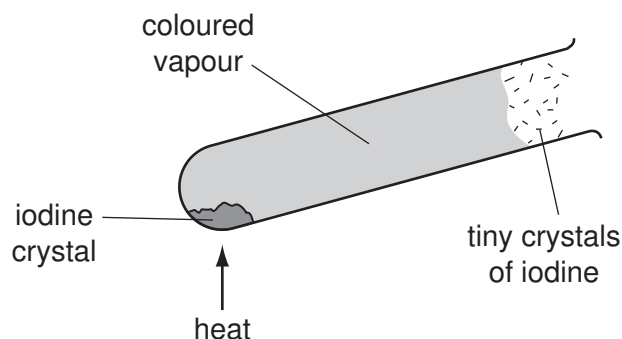

Fig. 6.3

- (i) What is the colour of the vapour?

..... [1]

(ii) What name is given to the change **from** a vapour **to** a solid?

..... [1]

