



UNIVERSITY OF CAMBRIDGE INTERNATIONAL EXAMINATIONS  
International General Certificate of Secondary Education

www.PapaCambridge.com

**CO-ORDINATED SCIENCES**

**0654/01**

Paper 1 Multiple Choice

**October/November 2007**

**45 minutes**

Additional Materials:      Multiple Choice Answer Sheet  
   Soft clean eraser  
   Soft pencil (type B or HB preferred)

\* 2 5 2 8 8 4 5 2 2 0 \*

**READ THESE INSTRUCTIONS FIRST**

Write in soft pencil.

Do not use staples, paper clips, highlighters, glue or correction fluid.

Write your name, Centre number and candidate number on the Answer Sheet in the spaces provided unless this has been done for you.

There are **forty** questions on this paper. Answer **all** questions. For each question there are four possible answers **A, B, C** and **D**.

Choose the **one** you consider correct and record your choice in **soft pencil** on the separate Answer Sheet.

**Read the instructions on the Answer Sheet very carefully.**

Each correct answer will score one mark. A mark will not be deducted for a wrong answer.

Any rough working should be done in this booklet.

A copy of the Periodic Table is printed on page 20.

This document consists of **18** printed pages and **2** blank pages.



1 Which feature is characteristic only of birds?

- A feathers and scales
- B fins and hard-shelled eggs
- C hair and scales
- D skin and soft-shelled eggs

2 The diagram shows a cork pinned to a leaf of a plant which is then exposed to light for 8 hours.

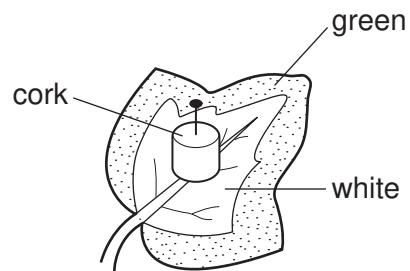

The leaf is then removed from the plant and a starch test carried out on it.

Which diagram shows the result of this starch test?

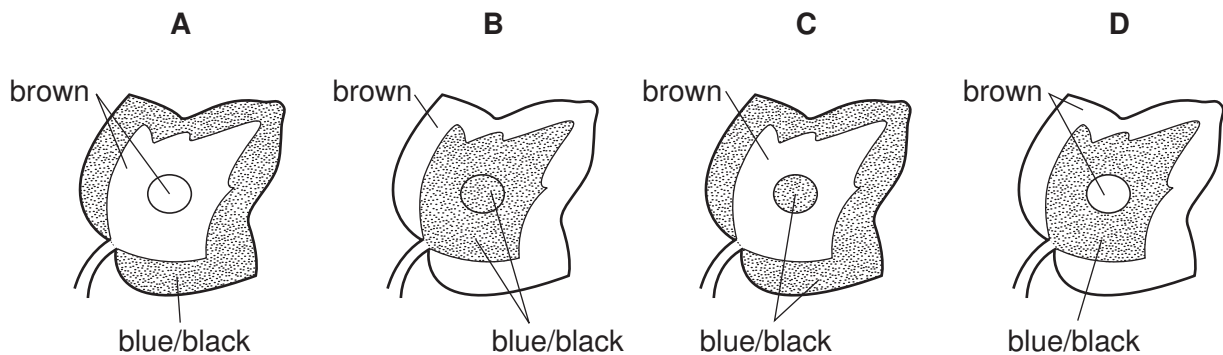

3 The diagram shows a section through the human thorax.

Which structure contains goblet cells and cilia?

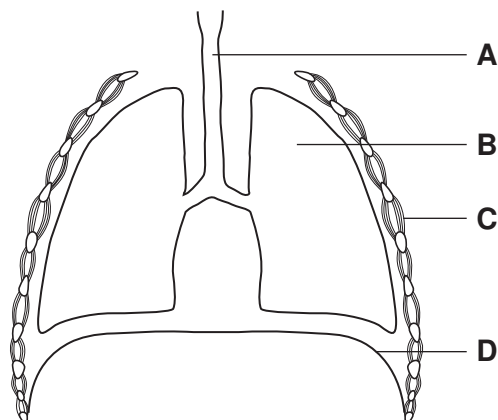

4 Which structures make up the nervous system?

- A brain, nerves, spinal cord
- B effectors, impulses, spinal cord
- C impulses, muscles, nerves
- D effectors, receptors, stimuli

5 The diagram shows a human heart, seen from the front.

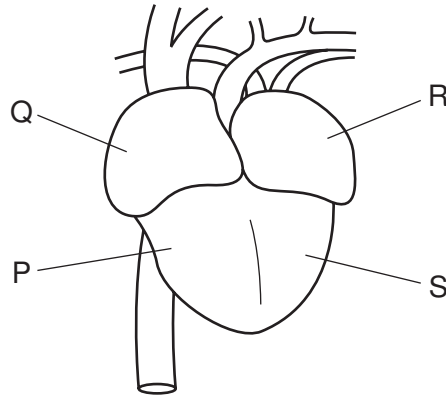

Which shows the sequence in which a blood cell passes through the four chambers of the heart?

- A  $P \rightarrow S \rightarrow R \rightarrow Q$
  - B  $Q \rightarrow P \rightarrow R \rightarrow S$
  - C  $R \rightarrow Q \rightarrow P \rightarrow S$
  - D  $S \rightarrow R \rightarrow Q \rightarrow P$
- 6 Which process in living organisms does **not** use energy from respiration?
- A growth
  - B movement
  - C photosynthesis
  - D temperature maintenance

7 Food tests are performed on four substances.

Which substance contains fat and protein?

	test reagent			
	Benedict's	biuret	ethanol	iodine
<b>A</b>	✓	x	x	✓
<b>B</b>	✓	✓	x	x
<b>C</b>	x	✓	✓	x
<b>D</b>	x	x	✓	✓

key

✓ = positive test result

x = negative test result

8 What is a cause and a symptom of scurvy?

	cause	symptom
<b>A</b>	lack of vitamin C	bleeding gums
<b>B</b>	lack of vitamin C	soft bones and teeth
<b>C</b>	lack of vitamin D	bleeding gums
<b>D</b>	lack of vitamin D	soft bones and teeth

9 What is most likely to happen if a diet contains excess proteins?

- A** Bacteria will form acids in the mouth.
- B** More amylase will be secreted by the pancreas.
- C** More fibre will be removed through the anus.
- D** More urea will be excreted by the kidneys.

10 Which graph shows the change in world population between 1750 and 2000?

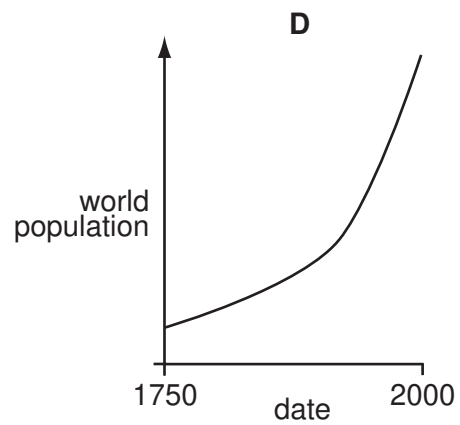
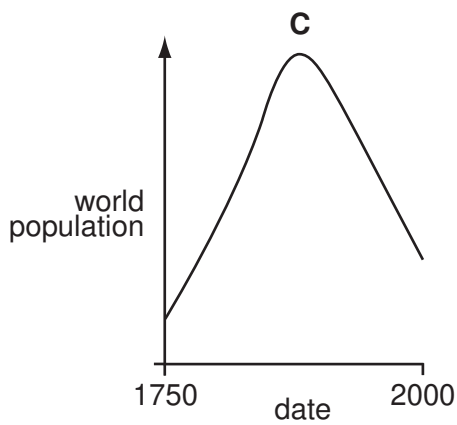
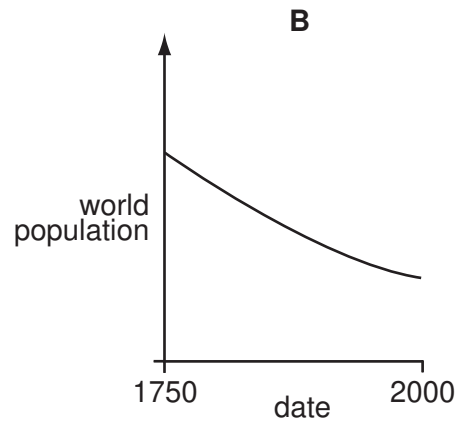
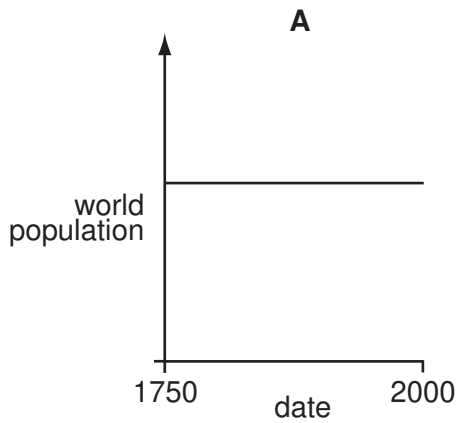

11 In human reproduction, where does fertilisation usually take place?

- A** ovary
- B** oviduct
- C** uterus
- D** vagina

12 Which shows the number of chromosomes in an organism and in its male and female gametes?

	organism	male gamete	female gamete
<b>A</b>	14	7	7
<b>B</b>	16	32	16
<b>C</b>	19	17	36
<b>D</b>	46	22	22

13 What can lead to global warming?

	nitrogen fixation	deforestation	denitrification	burning of fossil fuels
<b>A</b>	✓	✓	✓	x
<b>B</b>	x	x	✓	✓
<b>C</b>	✓	x	✓	x
<b>D</b>	x	✓	x	✓

14 The proton number of element X is 44. Its nucleon number is 145.

How many neutrons are there in an atom of X?

- A** 44                      **B** 101                      **C** 145                      **D** 189

15 An atom has 2 electrons in its outer shell.

Which element could this atom be?

	Ca	He
<b>A</b>	✓	✓
<b>B</b>	✓	x
<b>C</b>	x	✓
<b>D</b>	x	x

16 Which material is made from silicon(IV) oxide combined with metal oxides?

- A** brass  
**B** glass  
**C** polythene  
**D** steel

- 17 The apparatus shown is used to investigate the speed of reaction between hydrochloric acid and calcium carbonate.

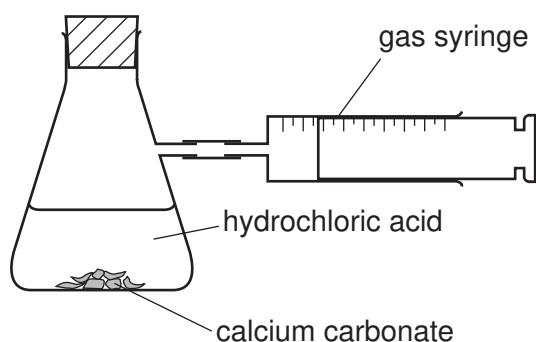

The time to collect  $50 \text{ cm}^3$  of gas is measured. Using concentrated acid and lumps of calcium carbonate, the time is 150 s.

In a second experiment, the time is 90 s.

Which change was made in the second experiment?

- A larger lumps of calcium carbonate
  - B less concentrated acid
  - C lower temperature
  - D powdered calcium carbonate
- 18 The table shows physical properties of some substances.

Which substance is metal?

	malleability	density	electrical conductivity
<b>A</b>	brittle	high density	high
<b>B</b>	brittle	low density	low
<b>C</b>	malleable	high density	high
<b>D</b>	malleable	low density	low

- 19 A petrochemical molecule undergoes the chemical change shown.

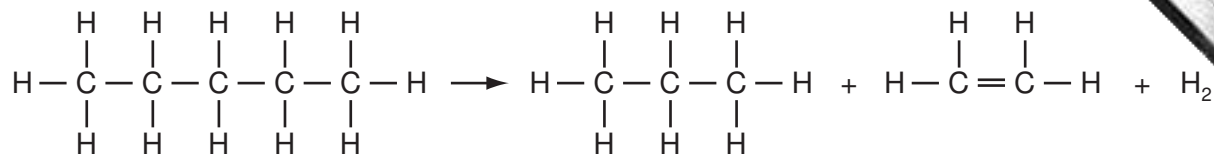

What is the chemical change?

- A cracking  
 B fractional distillation  
 C polymerisation  
 D reduction
- 20 Glucose gives a red precipitate when tested with reagent X.

Cellulose, a protein and starch are broken down into their monomers.

Which of these monomers also give a red precipitate when tested with reagent X?

	cellulose	protein	starch
A	✓	✓	✓
B	✓	✓	x
C	✓	x	✓
D	x	✓	✓

- 21 A reagent in solution is added to a solid sample of a fertiliser. The mixture is warmed and the gas given off changes the colour of damp litmus paper.

The test shows that the fertiliser contains ammonium ions.

What is the reagent and what is the **original** colour of the litmus paper used in the test?

	reagent	colour of litmus paper
A	acid	blue
B	acid	red
C	alkali	blue
D	alkali	red



22 A plant colour X is a mixture.

Chromatography is used to compare X with three other coloured mixtures, P, Q and R.

The results are shown in the diagram.

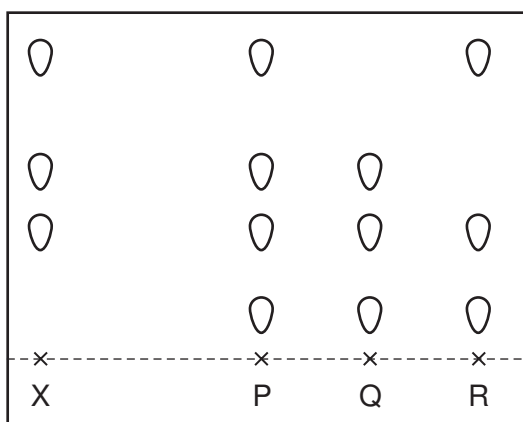

Which other mixtures contain the plant colour X?

- A P only
- B P and Q only
- C R only
- D P, Q and R

23 The element sulphur forms a colloid with water.

How are the sulphur particles held in the water and how do the particles affect a light beam shone on to the colloid?

	the particles are	the light beam is
<b>A</b>	dissolved	reflected
<b>B</b>	dissolved	scattered
<b>C</b>	suspended	reflected
<b>D</b>	suspended	scattered

24 The diagram shows a fire triangle.

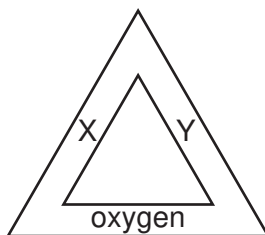

What are X and Y?

	X	Y
<b>A</b>	air	catalyst
<b>B</b>	air	heat
<b>C</b>	fuel	catalyst
<b>D</b>	fuel	heat

25 In which flask does iron rust?

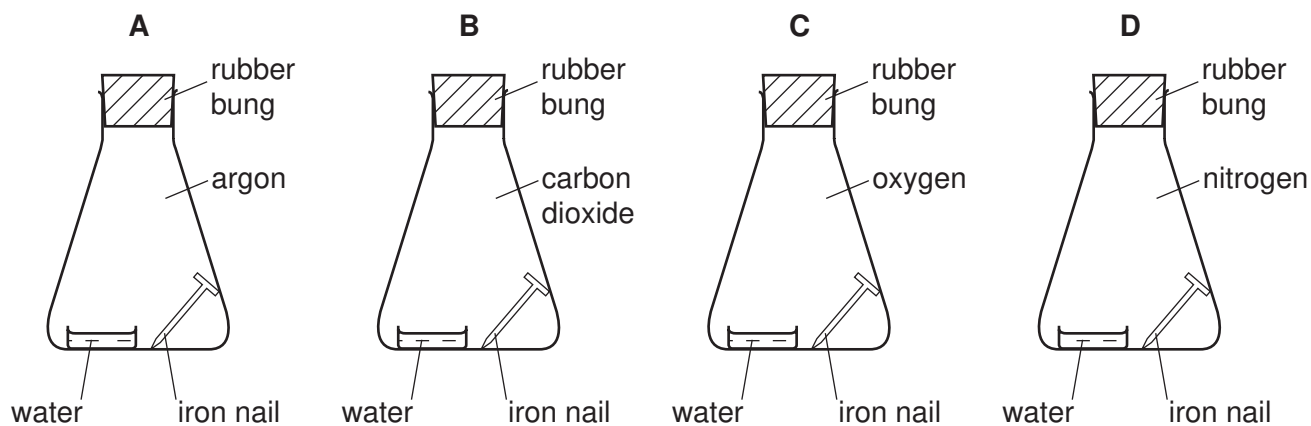

26 In separate experiments, an inert wire is dipped into two solutions, P and Q.

The wire is then placed in the flame of a Bunsen burner.

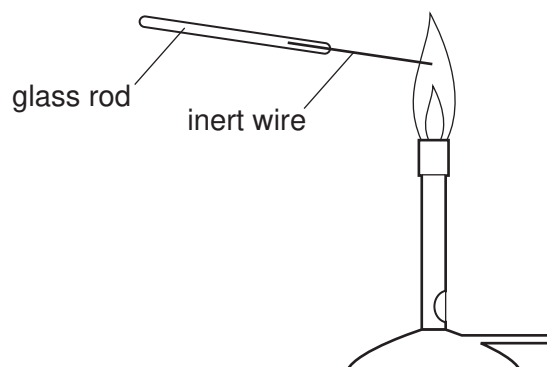

The table shows the results.

	solution P	solution Q
colour of Bunsen flame	green	yellow

Which metal ions are present in the solutions?

	P	Q
<b>A</b>	copper	potassium
<b>B</b>	copper	sodium
<b>C</b>	sodium	copper
<b>D</b>	sodium	potassium

27 Substance X is an ionic compound.

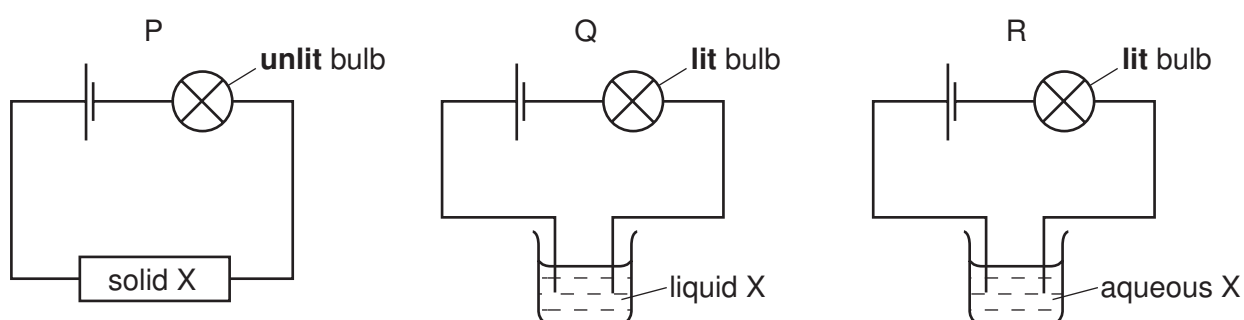

Which diagrams are correct for X?

- A** P and Q only
- B** P and R only
- C** R and Q only
- D** P, Q and R

28 Some water is poured into four tubes of different cross-sectional areas.

Which tube contains the largest volume of water?

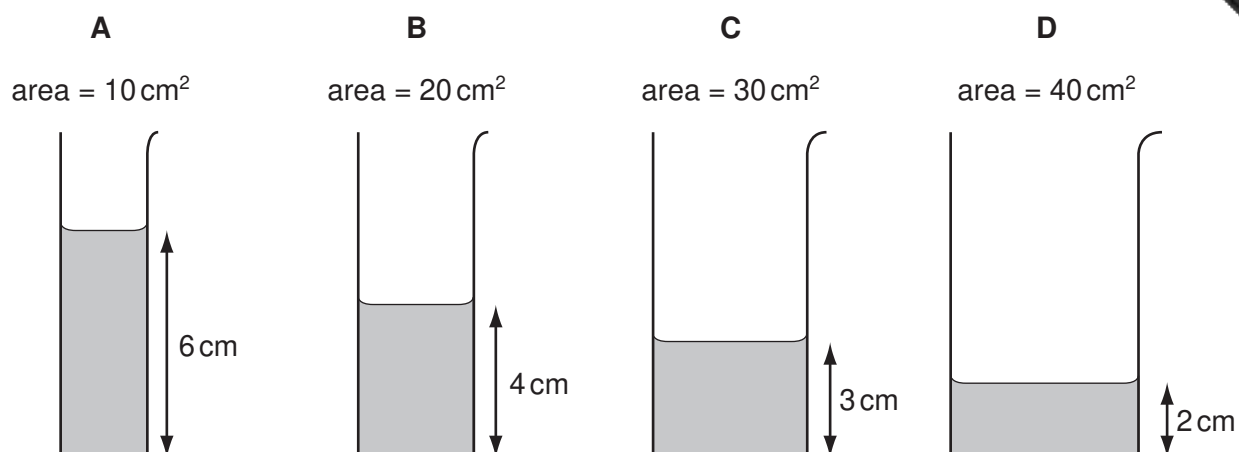

29 What are the correct units for force and for weight?

	force	weight
<b>A</b>	kg	kg
<b>B</b>	kg	N
<b>C</b>	N	kg
<b>D</b>	N	N

30 A metal drum has a mass of 200 kg when empty and 1000 kg when filled with  $1.0 \text{ m}^3$  of methylated spirit.

What is the density of methylated spirit?

- A**  $0.0050 \text{ kg/m}^3$
- B**  $0.11 \text{ kg/m}^3$
- C**  $800 \text{ kg/m}^3$
- D**  $1000 \text{ kg/m}^3$

- 31 A person uses chemical energy to run up some stairs.

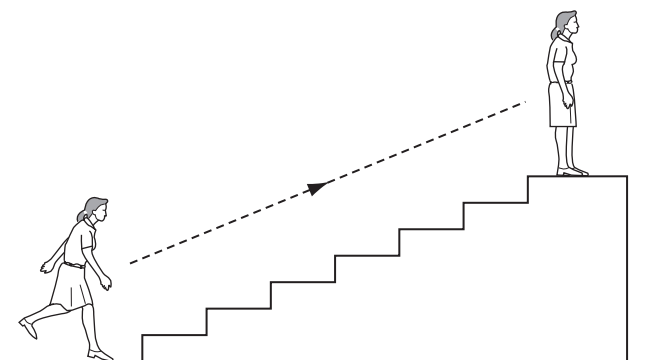

She stops at the top of the stairs.

What has the chemical energy been converted to when she is at the top of the stairs?

- A kinetic energy and gravitational potential energy
- B kinetic energy and nuclear energy
- C gravitational potential energy and heat energy
- D nuclear energy and heat energy

- 32 Some gas in a sealed plastic bag is cooled.

How do the gas molecules behave when this happens?

- A They move more quickly and become closer together.
- B They move more quickly and become further apart.
- C They move more slowly and become closer together.
- D They move more slowly and become further apart.

- 33 The diagram shows a section through a series of waves on water.

Which dotted line shows the position of the still water surface after the waves have passed?

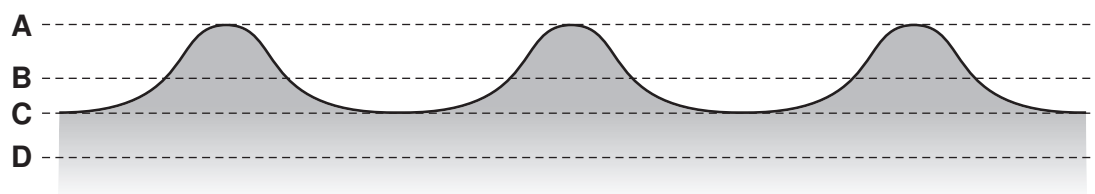

34 The diagram represents a sound wave.

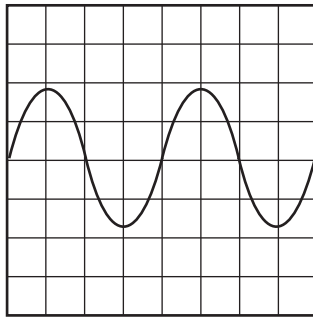

The frequency of the sound is increased.

The diagrams below are shown to the same scale. Which diagram represents the new sound wave?

**A**

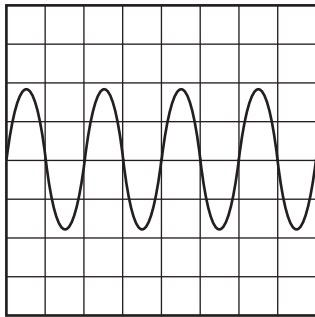

**B**

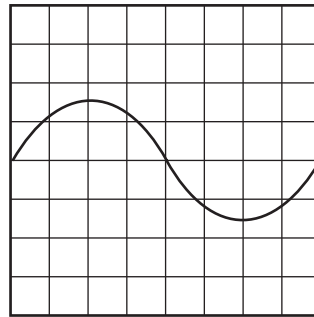

**C**

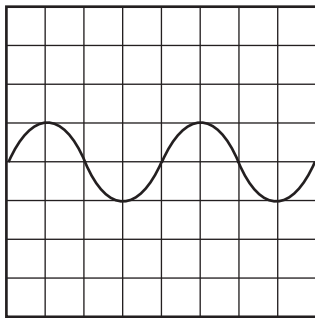

**D**

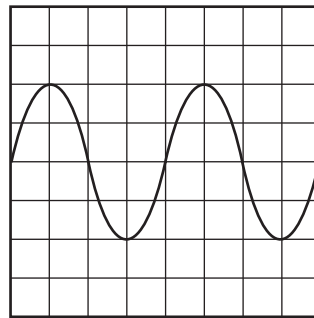

- 35 The circuit shows a current  $I$  in a resistor of resistance  $R$ .

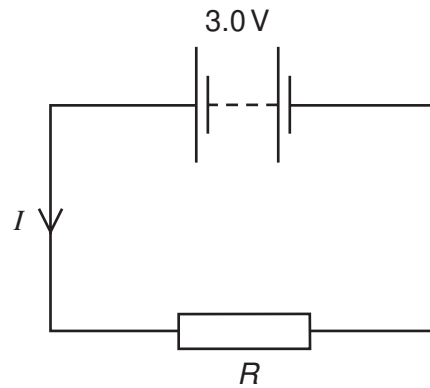

Which line gives possible values of  $I$  and  $R$ ?

	$I/A$	$R/\Omega$
<b>A</b>	1.5	1.5
<b>B</b>	1.5	2.0
<b>C</b>	6.0	2.0
<b>D</b>	4.0	12

- 36 A mains electrical circuit uses insulated copper cable and the cable overheats.

To prevent the cable overheating, how should the cable be changed, and why?

- A** Use thicker copper cable which has less resistance.
- B** Use thicker insulation which stops the heat escaping.
- C** Use thinner copper cable which has more resistance.
- D** Use thinner insulation which allows less heat to escape.

37 A sheet of paper is placed between a radioactive source and a detector.

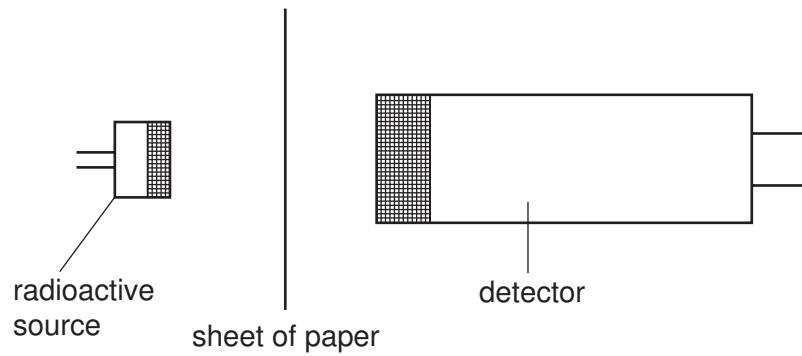

Which types of radiation can pass through the paper?

- A alpha radiation and beta radiation only
  - B alpha radiation and gamma radiation only
  - C beta radiation and gamma radiation only
  - D alpha radiation, beta radiation and gamma radiation
- 38 Which energy source is **not** renewable?
- A hydroelectric
  - B nuclear
  - C solar
  - D wind
- 39 The output from a power station is connected to the transmission cables through a transformer.
- What is the purpose of the transformer?
- A to change the frequency of the output
  - B to increase the current
  - C to increase the voltage
  - D to turn the current into alternating current



40 The diagram shows the use of a reed relay.

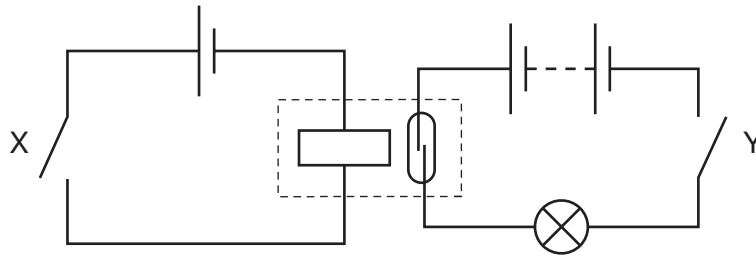

Which switch positions cause the lamp to light?

	X	Y
<b>A</b>	closed	closed
<b>B</b>	closed	open
<b>C</b>	open	closed
<b>D</b>	open	open





## DATA SHEET The Periodic Table of the Elements

Group																	
I	II											III	IV	V	VI	VII	0
											1 <b>H</b> Hydrogen 1						2 <b>He</b> Helium 2
7 <b>Li</b> Lithium 3	9 <b>Be</b> Beryllium 4											11 <b>B</b> Boron 5	12 <b>C</b> Carbon 6	14 <b>N</b> Nitrogen 7	16 <b>O</b> Oxygen 8	19 <b>F</b> Fluorine 9	20 <b>Ne</b> Neon 10
23 <b>Na</b> Sodium 11	24 <b>Mg</b> Magnesium 12											27 <b>Al</b> Aluminium 13	28 <b>Si</b> Silicon 14	31 <b>P</b> Phosphorus 15	32 <b>S</b> Sulphur 16	35.5 <b>Cl</b> Chlorine 17	40 <b>Ar</b> Argon 18
39 <b>K</b> Potassium 19	40 <b>Ca</b> Calcium 20	45 <b>Sc</b> Scandium 21	48 <b>Ti</b> Titanium 22	51 <b>V</b> Vanadium 23	52 <b>Cr</b> Chromium 24	55 <b>Mn</b> Manganese 25	56 <b>Fe</b> Iron 26	59 <b>Co</b> Cobalt 27	59 <b>Ni</b> Nickel 28	64 <b>Cu</b> Copper 29	65 <b>Zn</b> Zinc 30	70 <b>Ga</b> Gallium 31	73 <b>Ge</b> Germanium 32	75 <b>As</b> Arsenic 33	79 <b>Se</b> Selenium 34	80 <b>Br</b> Bromine 35	84 <b>Kr</b> Krypton 36
85 <b>Rb</b> Rubidium 37	88 <b>Sr</b> Strontium 38	89 <b>Y</b> Yttrium 39	91 <b>Zr</b> Zirconium 40	93 <b>Nb</b> Niobium 41	96 <b>Mo</b> Molybdenum 42	96 <b>Tc</b> Technetium 43	101 <b>Ru</b> Ruthenium 44	103 <b>Rh</b> Rhodium 45	106 <b>Pd</b> Palladium 46	108 <b>Ag</b> Silver 47	112 <b>Cd</b> Cadmium 48	115 <b>In</b> Indium 49	119 <b>Sn</b> Tin 50	122 <b>Sb</b> Antimony 51	128 <b>Te</b> Tellurium 52	127 <b>I</b> Iodine 53	131 <b>Xe</b> Xenon 54
133 <b>Cs</b> Caesium 55	137 <b>Ba</b> Barium 56	139 <b>La</b> Lanthanum 57 *	178 <b>Hf</b> Hafnium 72	181 <b>Ta</b> Tantalum 73	184 <b>W</b> Tungsten 74	186 <b>Re</b> Rhenium 75	190 <b>Os</b> Osmium 76	192 <b>Ir</b> Iridium 77	195 <b>Pt</b> Platinum 78	197 <b>Au</b> Gold 79	201 <b>Hg</b> Mercury 80	204 <b>Tl</b> Thallium 81	207 <b>Pb</b> Lead 82	209 <b>Bi</b> Bismuth 83	210 <b>Po</b> Polonium 84	210 <b>At</b> Astatine 85	210 <b>Rn</b> Radon 86
87 <b>Fr</b> Francium 87	226 <b>Ra</b> Radium 88	227 <b>Ac</b> Actinium 89 †															

\*58-71 Lanthanoid series  
†90-103 Actinoid series

Key

a
<b>X</b>
b

a = relative atomic mass  
X = atomic symbol  
b = proton (atomic) number

140 <b>Ce</b> Cerium 58	141 <b>Pr</b> Praseodymium 59	144 <b>Nd</b> Neodymium 60	<b>Pm</b> Promethium 61	150 <b>Sm</b> Samarium 62	152 <b>Eu</b> Europium 63	157 <b>Gd</b> Gadolinium 64	159 <b>Tb</b> Terbium 65	162 <b>Dy</b> Dysprosium 66	165 <b>Ho</b> Holmium 67	167 <b>Er</b> Erbium 68	169 <b>Tm</b> Thulium 69	173 <b>Yb</b> Ytterbium 70	175 <b>Lu</b> Lutetium 71
232 <b>Th</b> Thorium 90	<b>Pa</b> Protactinium 91	238 <b>U</b> Uranium 92	<b>Np</b> Neptunium 93	<b>Pu</b> Plutonium 94	<b>Am</b> Americium 95	<b>Cm</b> Curium 96	<b>Bk</b> Berkelium 97	<b>Cf</b> Californium 98	<b>Es</b> Einsteinium 99	<b>Fm</b> Fermium 100	<b>Md</b> Mendelevium 101	<b>No</b> Nobelium 102	<b>Lr</b> Lawrencium 103

The volume of one mole of any gas is 24 dm<sup>3</sup> at room temperature and pressure (r.t.p.).