



UNIVERSITY OF CAMBRIDGE INTERNATIONAL EXAMINATIONS
International General Certificate of Secondary Education

CANDIDATE
NAME

CENTRE
NUMBER

--	--	--	--	--

CANDIDATE
NUMBER

--	--	--	--

* 5 9 8 0 7 0 7 6 6 5 *

CO-ORDINATED SCIENCES

0654/02

Paper 2 (Core)

May/June 2009

2 hours

Candidates answer on the Question Paper.

No Additional Materials are required.

READ THESE INSTRUCTIONS FIRST

Write your Centre number, candidate number and name on all the work you hand in.

Write in dark blue or black pen.

You may use a soft pencil for any diagrams, graphs, tables or rough working.

Do not use staples, paper clips, highlighters, glue or correction fluid.

DO NOT WRITE IN ANY BARCODES.

Answer **all** questions.

A copy of the Periodic Table is printed on page 28.

At the end of the examination, fasten all your work securely together.

The number of marks is given in brackets [] at the end of each question or part question.

For Examiner's Use	
1	
2	
3	
4	
5	
6	
7	
8	
9	
10	
11	
Total	

This document consists of **25** printed pages and **3** blank pages.



- 1 (a) Many people have survived accidents where they have been exposed to radiation from radioactive materials. Such exposure can have serious effects on health.

The table and graph show how the dose (amount) of radiation received is linked to a type of cancer called leukaemia. The radiation dose is measured in units called grays.

Table 1.1

radiation dose/grays	incidences of leukaemia/cases per 10 000 people per year
1.0	1.0
2.5	2.3
5.0	
10.0	10.1
15.0	15.2

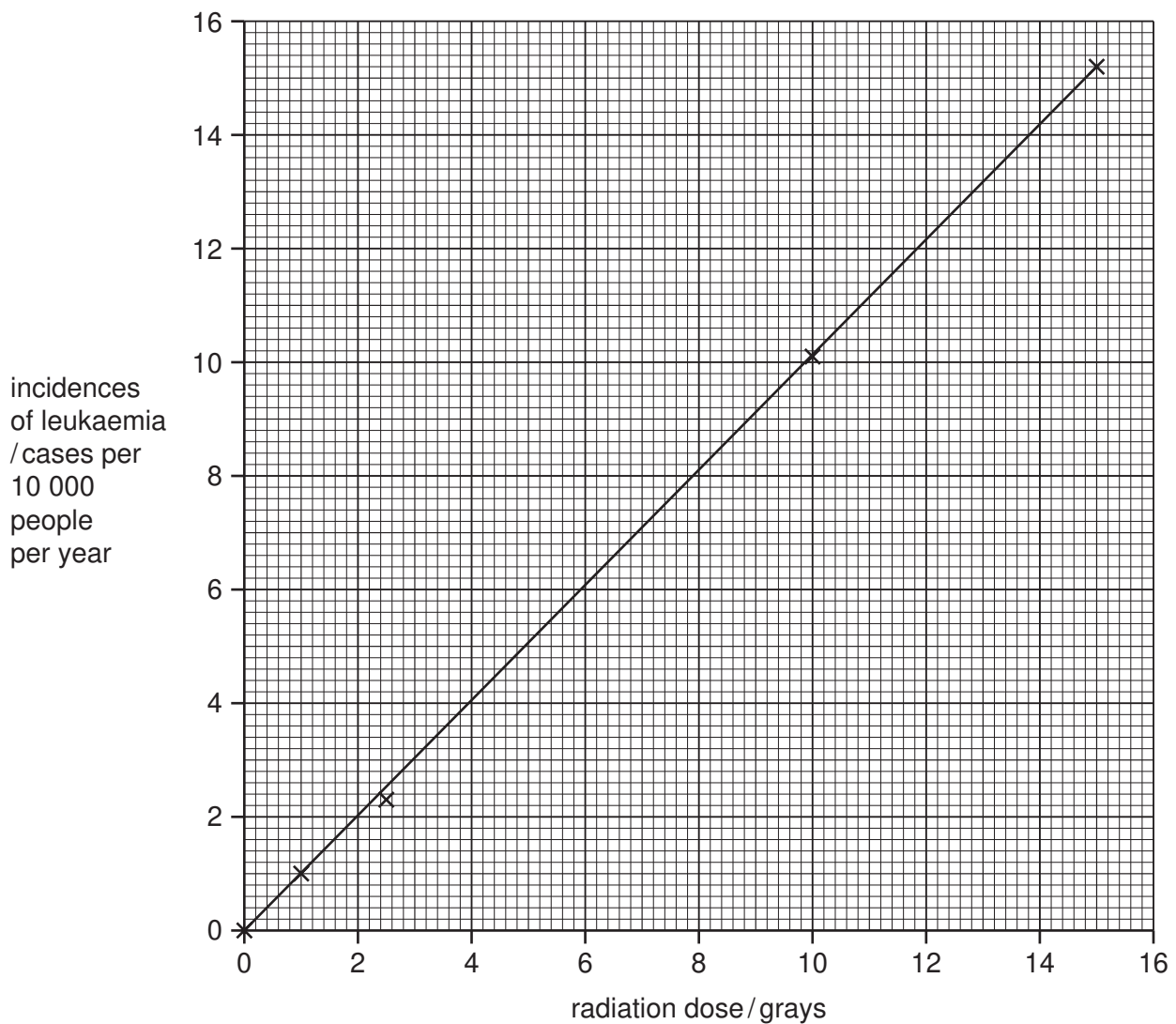

Fig. 1.1

(i) The result for 5.0 grays has been missed out of the table.

Use the graph to help you fill in the missing result in the table.

(ii) What is the relationship between the ionising radiation and the incidence of leukaemia?

.....
..... [1]

(iii) Name **one** other health hazard, apart from leukaemia and other cancers, caused by ionising radiation.

..... [1]

(b) The three types of nuclear radiation from naturally occurring sources are alpha, beta and gamma. They can be identified by their different penetrating powers.

Gamma radiation can pass through a thick layer of lead. Explain how you could identify alpha and beta radiation by their penetrating powers.

alpha radiation

beta radiation

..... [2]

(c) Radon-222 has a half-life of four days.

(i) What is meant by the term *half-life*?

.....
..... [1]

(ii) 1 milligram of radon-222 is allowed to decay.

Calculate after how many days there would be 0.125 milligrams of radon-222 remaining.

Show your working.

..... [2]

2 Fig. 2.1 shows the water cycle.

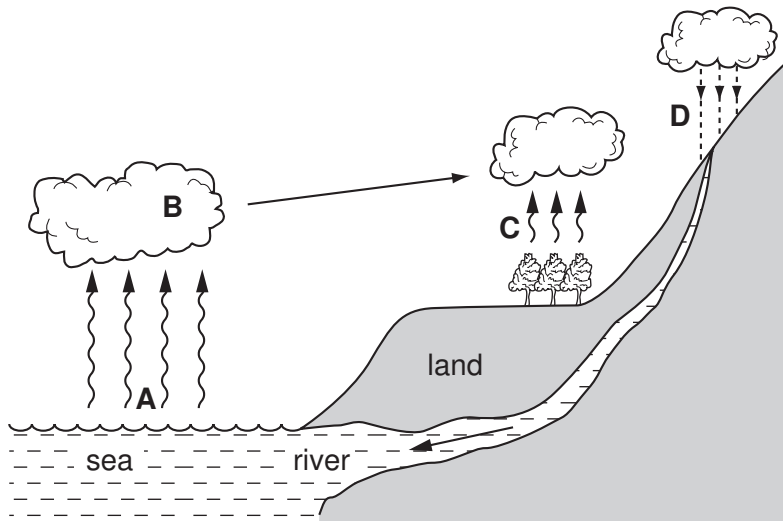

Fig. 2.1

(a) Choose the word from the list below that describes each of the stages A, B, C and D.

- | | | |
|--------------|---------------|---------------|
| condensation | evaporation | melting |
| osmosis | precipitation | transpiration |

- A
- B
- C
- D

[4]

(b) Describe **two** ways in which deforestation may affect the water cycle.

-
-
-

[2]

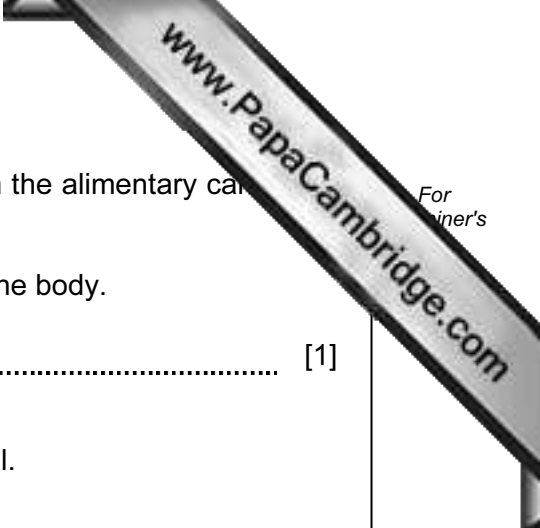

(c) Water is an essential part of the diet. Water is absorbed from the alimentary canal into the blood. It is transported around the body to every cell.

(i) Name the part of the blood that transports water around the body.

..... [1]

(ii) Describe how water moves from the blood into a body cell.

.....
.....
.....
..... [3]

(d) Water that is to be used for drinking is often treated with chlorine.

Explain why this is done.

.....
.....
..... [2]

3 Food colourings contain molecules which make food appear coloured.

(a) Explain the meaning of the term *molecule*.

.....
.....
..... [2]

(b) Fig. 3.1 shows two pieces of cloth, **A** and **B**, stained with the same food colouring.

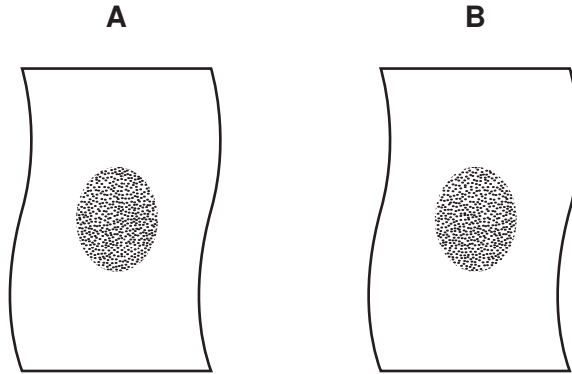

Fig. 3.1

Cloth **A** was washed with soap in hard water.

Cloth **B** was washed in the same way with the same amount of soap in soft water.

Fig. 3.2 shows the pieces of cloth after washing.

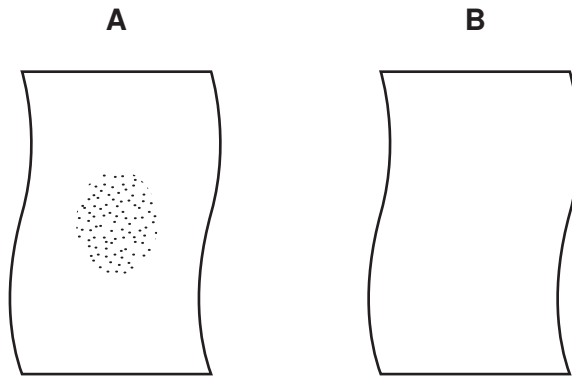
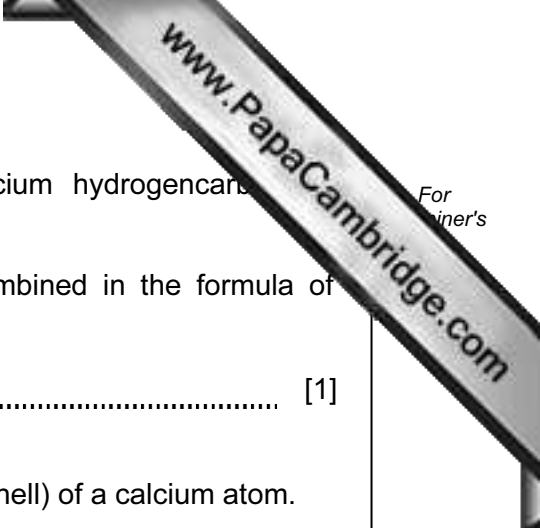

Fig. 3.2

Explain briefly, in terms of water hardness, why more of the food colouring was removed from cloth **B** than from cloth **A**.

.....
.....
.....
..... [3]



(c) One compound which causes hardness in water is calcium hydrogencarbonate, $\text{Ca}(\text{HCO}_3)_2$.

(i) State the total number of atoms which are shown combined in the formula of calcium hydrogencarbonate.

..... [1]

(ii) State the number of electrons in the outer energy level (shell) of a calcium atom.

Explain your answer briefly.

number of outer electrons

explanation

.....

..... [2]

- 4 (a) A student investigated how a change in potential difference across a lamp affects the current flowing through it.

She used wires to connect the components shown in Fig. 4.1 to make a circuit.

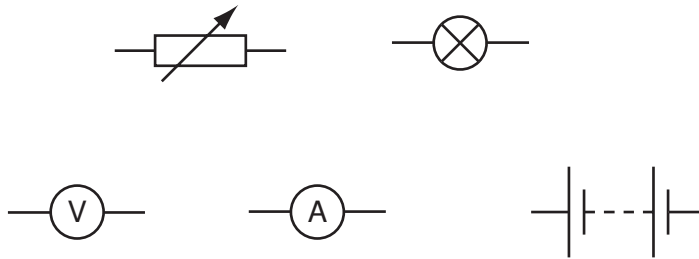

Fig. 4.1

- (i) Using the correct symbols from Fig. 4.1, draw a diagram to show the circuit she used.

[3]

- (ii) Explain why the variable resistor is included in the circuit.

.....
 [1]

- (iii) Her results are shown in Table 4.1.

Table 4.1

potential difference across lamp / V	current through lamp / A	resistance of lamp filament / Ω
4	1.2	3.3
8	1.5	
12	1.7	7.1

Complete the table by calculating the missing resistance and writing your answer in the empty box.

State the formula that you use and show your working.

formula

working

[2]

- (iv) The student concluded that the relationship between potential difference and current did not correspond to Ohm's law.

Explain why the relationship between potential difference and current for the lamp did not correspond to Ohm's law.

.....

.....

..... [2]

(b) Electricity can kill.

Identify and explain the electrical hazard shown in Fig. 4.2.

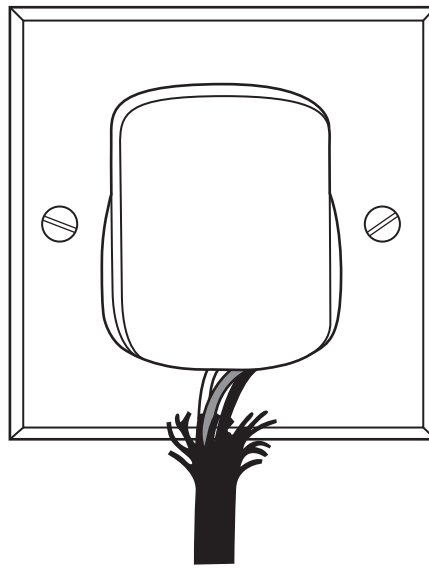

Fig. 4.2

.....

.....

.....

..... [2]

Please turn over for Question 5.

5 Fig. 5.1 shows three vertebrates.

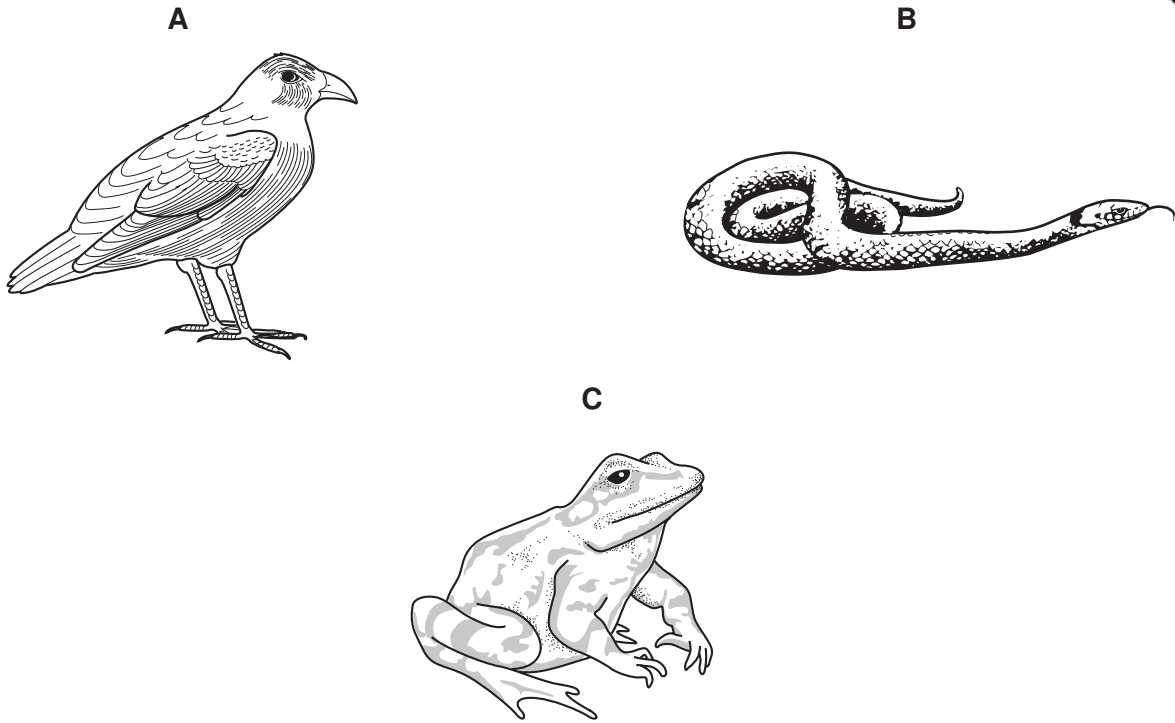

Fig. 5.1

(a) (i) Animal **A** is a bird. State two features, visible on Fig. 5.1, that are characteristic of birds.

- 1
- 2 [2]

(ii) Name the classes to which animals **B** and **C** belong.

- B**
- C** [2]

(iii) Animal **C** belongs to the genus *Rana* and the species *temporaria*.

Write the binomial for animal **C**.

..... [1]

(iv) Animal **C** spends part of its time in water.

Describe **one** way, visible in Fig. 5.1, in which animal **C** is adapted for life in water.

.....
..... [2]

(b) Fig. 5.2 shows how the temperatures of animal **A** and animal **C** change when the temperature of their environment changes.

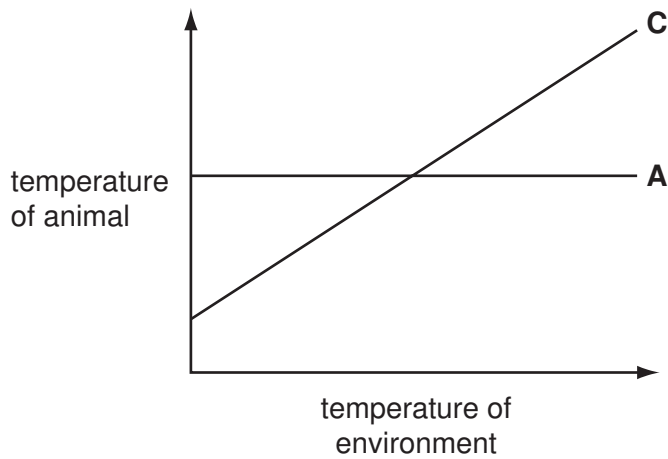

Fig. 5.2

(i) Explain how Fig. 5.2 shows that animal **A** regulates its temperature but animal **C** does not.

.....
..... [1]

(ii) Name **one** group of vertebrates, other than birds, that regulates body temperature.
..... [1]

(iii) Explain why it is useful to regulate body temperature.
.....
.....
..... [2]

(iv) Animals that regulate their body temperature need to eat much more food than animals that do not.
Suggest an explanation for this.
.....
.....
..... [2]

- 6 (a) Many metals react with dilute acids.

Complete the word equation for the reaction of magnesium with dilute sulfuric acid.

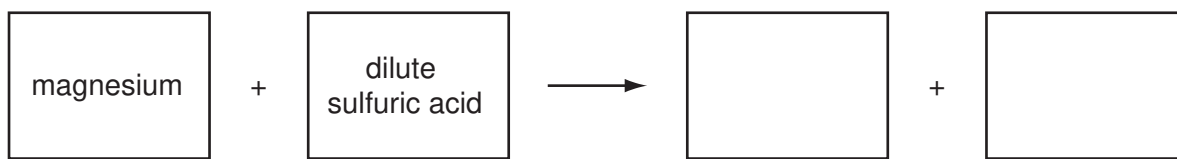

[2]

- (b) A student used the apparatus shown in Fig. 6.1 to investigate the rate of reaction between sulfuric acid and magnesium.

To start the reaction, she tilted the flask to mix the reactants.

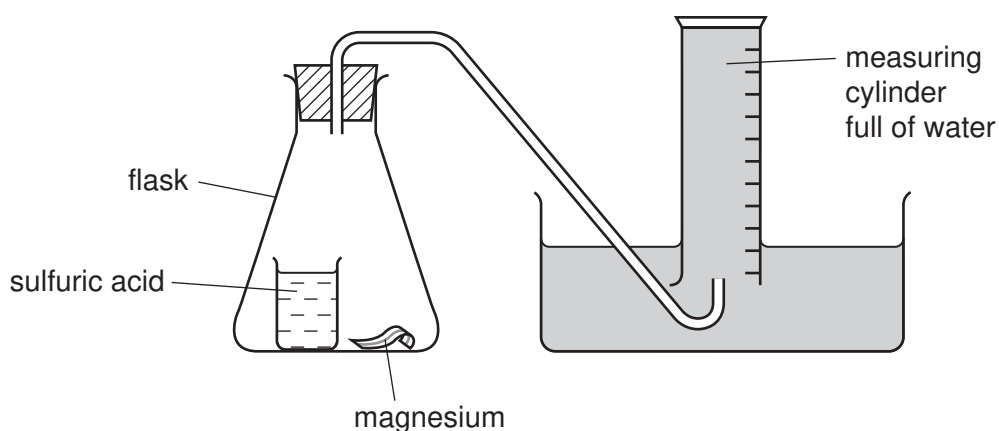

Fig. 6.1

She timed how long it took for 30.0 cm³ of gas to collect in the measuring cylinder.

Some of her results are shown in Table 6.1.

Table 6.1

experiment number	time to collect 30 cm ³ gas / seconds
1	73
2	41
3	119

- (i) Explain in which experiment, 1, 2 or 3, the rate of reaction was highest.

.....
 [1]

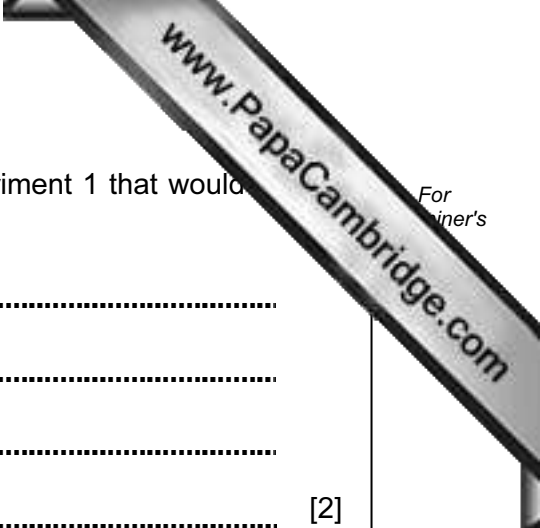

(ii) Suggest two changes to the reaction conditions in experiment 1 that would make the rate of reaction to decrease.

1
.....

2
.....

[2]

(iii) During experiment 1, the student noticed that the flask became warm.

Explain this observation.

.....
.....
.....

[2]

7 A diver is working under water, wearing a diving suit and helmet.

(a) The diving helmet has a plastic window of area 100 cm^2 . The air pressure inside the helmet is the same as the water pressure outside.

(i) At a depth of 40 m, the diver breathes air at a pressure of 50 N/cm^2 .

Calculate the force exerted by the air on the helmet window at this depth.

Use the formula

$$\text{pressure} = \text{force} / \text{area}$$

Show your working.

..... N [2]

(ii) At the surface of the sea, the pressure of the atmosphere is 10 N/cm^2 .

Suggest a value for the pressure at a depth of 10 m. Explain your answer.

..... N/cm^2

.....

..... [2]

(b) The diver sees a squid. A squid moves by forcing out a jet of water.

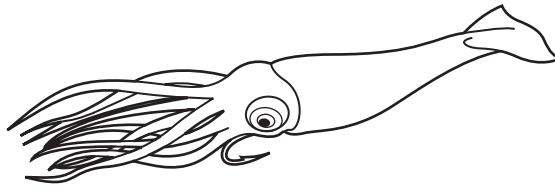

This moving water has momentum.

The mass of water forced out is 1.2kg and has a velocity of 10 m/s.

Calculate the momentum of the moving water.

State the formula that you use and show your working.

formula

working

..... kg m/s [2]

(c) Water waves on the surface of the sea are transverse waves.

(i) Give **one** other example of a transverse wave.

..... [1]

(ii) How does a transverse wave differ from a longitudinal wave?

..... [1]

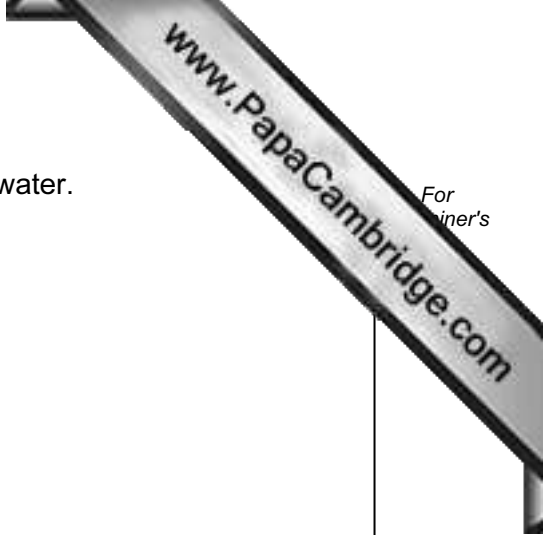

8 A student carried out an investigation into the response of plant shoots to light.

He grew four maize seedlings and treated them as follows.

- He did nothing to seedlings **A** and **B**.
- He cut the tip off seedling **C**.
- He covered the tips of seedling **D** with black paper.

He placed seedling **A** where it received light from all directions.

He placed seedlings **B**, **C** and **D** in a container where they received light from one side only.

Fig. 8.1 shows the appearance of the four seedlings when the experiment was first set up, and after one day.

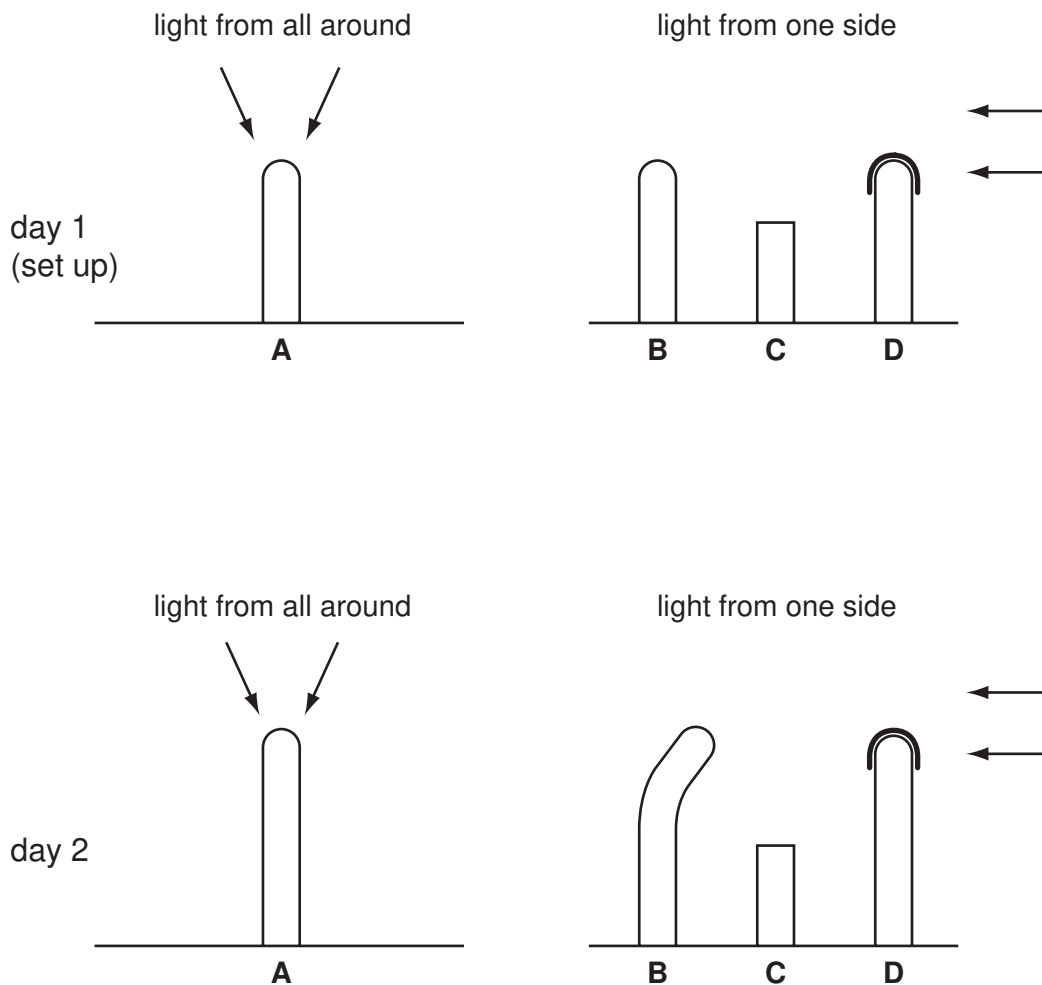

Fig. 8.1

(a) The student concluded that the tip of a shoot is needed for growth.

Describe the evidence in Fig. 8.1 that supports his conclusion.

.....
.....
..... [2]

(b) Compare the appearance of shoots **A** and **B** on day 2.

.....
.....
..... [2]

(c) Explain how the results of this experiment show that the receptor that is sensitive to light is at the tip of the shoot.

.....
.....
..... [2]

(d) Explain why it is useful for a plant to grow towards the light.

.....
.....
..... [2]

- 9 (a) Fig. 9.1 shows apparatus that a student used to investigate the electrolysis of concentrated sodium chloride solution.

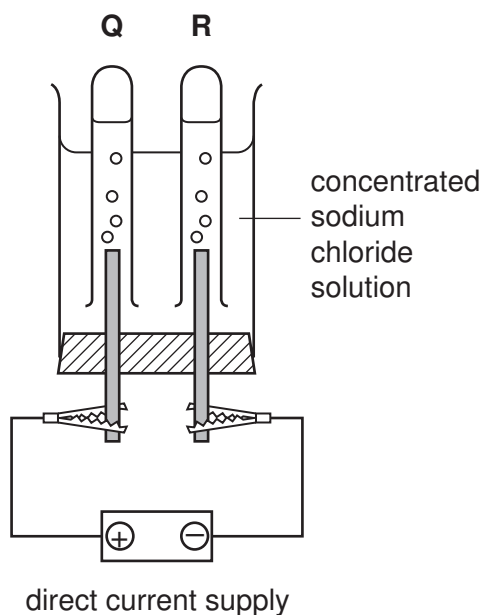

Fig. 9.1

When an electric current flowed through the circuit, gases collected in tubes **Q** and **R**.

- (i) Label the cathode in Fig. 9.1. [1]

- (ii) The gas in tube **Q** bleached damp litmus paper.

Name the gas which collected in tube **Q**. [1]

- (iii) Name the gas which collected in tube **R**. [1]

- (iv) During this electrolysis, the pH of the solution increased.

Explain why this occurred.

.....

 [2]

(b) When chlorine gas is bubbled through a colourless solution of potassium iodide, the solution turns dark brown because the element iodine is formed.

(i) Name this type of chemical reaction and explain briefly why it has occurred.

name of chemical reaction

why the reaction occurred

.....

..... [2]

(ii) Write a **word** equation for the reaction.

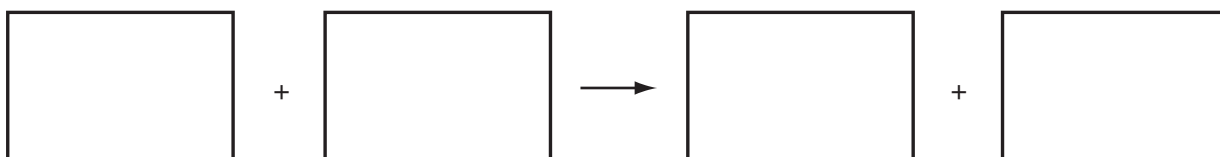

[1]

10 (a) A plate on the back of an electric cooker gives this information.

power	5000 W
voltage	250 V
a.c. frequency	50 Hz

Fig. 10.1

(i) Explain what is meant by an *a.c. frequency of 50 Hz*.

.....

 [2]

(ii) Calculate the current which would flow when the cooker was using 5000 W of power.

Use the formula

$$\text{power} = \text{voltage} \times \text{current}$$

Show your working.

..... A [1]

(b) The manufacturers of the cooker claim that it has an *efficiency of 50%*.

Explain what this means.

.....

 [2]

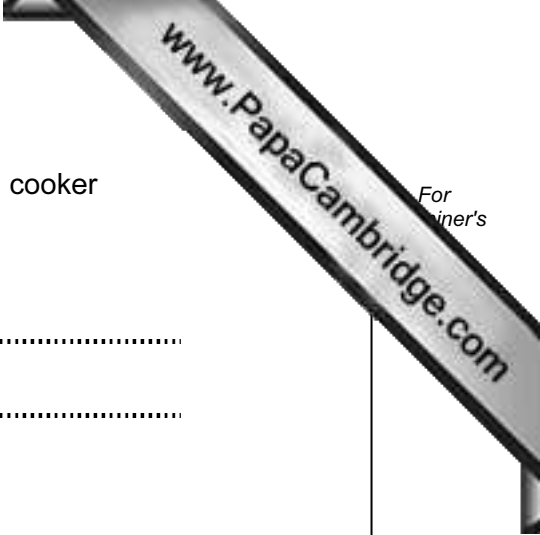

(c) Explain, in terms of heat transfer, why saucepans used on the cooker are made of aluminium,

.....
.....

have wooden handles.

.....
.....

[2]

11 Soybeans (soya beans) provide amino acids, which humans need for growth and repair.

(a) (i) Name the type of compound that is formed when amino acids link together in polymer molecules.

..... [1]

(ii) Write the chemical symbol of the element that is found in all amino acids, but which is **not** found in carbohydrates.

..... [1]

(b) Soybeans contain soybean oil. This is extracted by crushing the beans and then adding the hydrocarbon solvent, hexane. The oil dissolves in hexane which is then separated from the solution by heating.

(i) Suggest why it is possible to remove hexane from the soybean oil by heating the solution.

.....
..... [1]

(ii) Hexane is a saturated hydrocarbon.

Explain the meaning of the term *saturated hydrocarbon*.

.....
.....
..... [2]

(iii) Hexane molecules contain covalent bonds.

Describe briefly, in terms of electrons, what happens when a covalent bond forms between two atoms.

.....
.....
..... [2]

- (c) Increasing amounts of soybean oil are being used to produce biodiesel. Biodiesel is an alternative fuel to diesel, obtained from petroleum (crude oil).

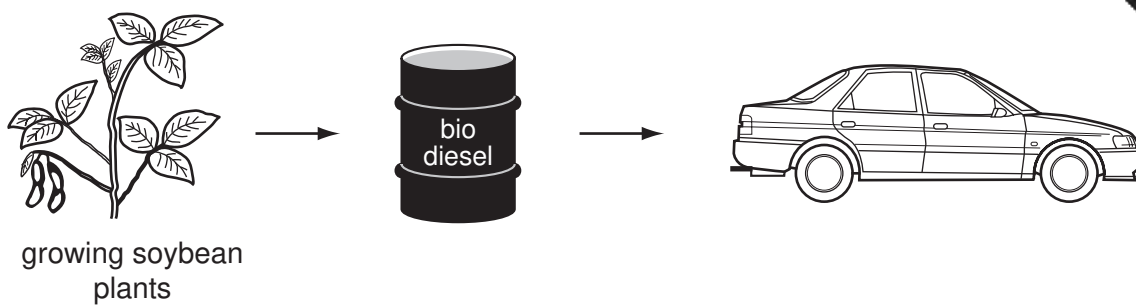

Fig. 11.1

Burning diesel and biodiesel produces similar amounts of carbon dioxide.

However, it is believed that burning biodiesel will cause less increase in the carbon dioxide concentration in the atmosphere.

Suggest the reason for this.

.....
.....
..... [2]

- (d) Biodiesel contains hardly any sulfur compounds.

Explain why this is an advantage of biodiesel when compared to diesel.

.....
.....
.....
..... [2]

DATA SHEET

The Periodic Table of the Elements

Group																					
I	II											III	IV	V	VI	VII	0				
										1 H Hydrogen 1											4 He Helium 2
7 Li Lithium 3	9 Be Beryllium 4											11 B Boron 5	12 C Carbon 6	14 N Nitrogen 7	16 O Oxygen 8	19 F Fluorine 9	20 Ne Neon 10				
23 Na Sodium 11	24 Mg Magnesium 12											27 Al Aluminium 13	28 Si Silicon 14	31 P Phosphorus 15	32 S Sulfur 16	35.5 Cl Chlorine 17	40 Ar Argon 18				
39 K Potassium 19	40 Ca Calcium 20	45 Sc Scandium 21	48 Ti Titanium 22	51 V Vanadium 23	52 Cr Chromium 24	55 Mn Manganese 25	56 Fe Iron 26	59 Co Cobalt 27	59 Ni Nickel 28	64 Cu Copper 29	65 Zn Zinc 30	70 Ga Gallium 31	73 Ge Germanium 32	75 As Arsenic 33	79 Se Selenium 34	80 Br Bromine 35	84 Kr Krypton 36				
85 Rb Rubidium 37	88 Sr Strontium 38	89 Y Yttrium 39	91 Zr Zirconium 40	93 Nb Niobium 41	96 Mo Molybdenum 42	96 Tc Technetium 43	101 Ru Ruthenium 44	103 Rh Rhodium 45	106 Pd Palladium 46	108 Ag Silver 47	112 Cd Cadmium 48	115 In Indium 49	119 Sn Tin 50	122 Sb Antimony 51	128 Te Tellurium 52	127 I Iodine 53	131 Xe Xenon 54				
133 Cs Caesium 55	137 Ba Barium 56	139 La Lanthanum 57 *	178 Hf Hafnium 72	181 Ta Tantalum 73	184 W Tungsten 74	186 Re Rhenium 75	190 Os Osmium 76	192 Ir Iridium 77	195 Pt Platinum 78	197 Au Gold 79	201 Hg Mercury 80	204 Tl Thallium 81	207 Pb Lead 82	209 Bi Bismuth 83	209 Po Polonium 84	209 At Astatine 85	209 Rn Radon 86				
87 Fr Francium	226 Ra Radium	227 Ac Actinium †																			

*58-71 Lanthanoid series

†90-103 Actinoid series

a	a = relative atomic mass
X	X = atomic symbol
b	b = proton (atomic) number

140 Ce Cerium 58	141 Pr Praseodymium 59	144 Nd Neodymium 60	144 Pm Promethium 61	150 Sm Samarium 62	152 Eu Europium 63	157 Gd Gadolinium 64	159 Tb Terbium 65	162 Dy Dysprosium 66	165 Ho Holmium 67	167 Er Erbium 68	169 Tm Thulium 69	173 Yb Ytterbium 70	175 Lu Lutetium 71
232 Th Thorium 90	238 Pa Protactinium 91	238 U Uranium 92	238 Np Neptunium 93	238 Pu Plutonium 94	238 Am Americium 95	238 Cm Curium 96	238 Bk Berkelium 97	238 Cf Californium 98	238 Es Einsteinium 99	238 Fm Fermium 100	238 Md Mendelevium 101	238 No Nobelium 102	238 Lr Lawrencium 103

The volume of one mole of any gas is 24 dm³ at room temperature and pressure (r.t.p.).

Permission to reproduce items where third-party owned material protected by copyright is included has been sought and cleared where possible. Every reasonable effort has been made by the publisher (UCLES) to trace copyright holders, but if any items requiring clearance have unwittingly been included, the publisher will be pleased to make amends at the earliest possible opportunity.

University of Cambridge International Examinations is part of the Cambridge Assessment Group. Cambridge Assessment is the brand name of University of Cambridge International Examinations.