



UNIVERSITY OF CAMBRIDGE INTERNATIONAL EXAMINATIONS
International General Certificate of Secondary Education

www.PapaCambridge.com

CO-ORDINATED SCIENCES

0654/11

Paper 1 Multiple Choice

May/June 2010

45 minutes

Additional Materials: Multiple Choice Answer Sheet
Soft clean eraser
Soft pencil (type B or HB is recommended)

* 2 3 9 2 5 5 7 3 0 6 *

READ THESE INSTRUCTIONS FIRST

Write in soft pencil.

Do not use staples, paper clips, highlighters, glue or correction fluid.

Write your name, Centre number and candidate number on the Answer Sheet in the spaces provided unless this has been done for you.

There are **forty** questions on this paper. Answer **all** questions. For each question there are four possible answers **A, B, C** and **D**.

Choose the **one** you consider correct and record your choice in **soft pencil** on the separate Answer Sheet.

Read the instructions on the Answer Sheet very carefully.

Each correct answer will score one mark. A mark will not be deducted for a wrong answer.

Any rough working should be done in this booklet.

A copy of the Periodic Table is printed on page **20**.

This document consists of **17** printed pages and **3** blank pages.



- 1 The diagram shows a section through a flower.

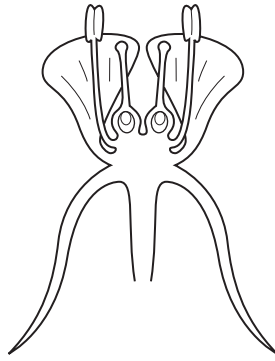

Use the key to identify the flower.

- | | | |
|---|---|----------|
| 1 | flower with many ovules in each ovary | go to 2 |
| | flower with one ovule in each ovary | go to 3 |
| 2 | filaments longer than styles | A |
| | filaments shorter than styles | B |
| 3 | petals shorter than sepals | C |
| | petals longer than sepals | D |

- 2 The diagram shows part of a plant cell.

In which region does most of the cell's respiration occur?

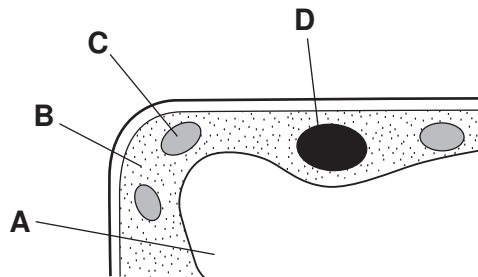

- 3 A plant, each leaf of which is green and white, is destarched. It is then placed in light and black paper is placed over part of one leaf as shown.

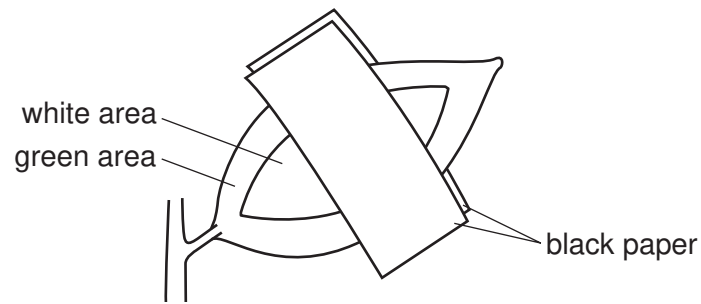

After 12 hours, the leaf is tested for starch using iodine solution. The diagram below shows the leaf after this test.

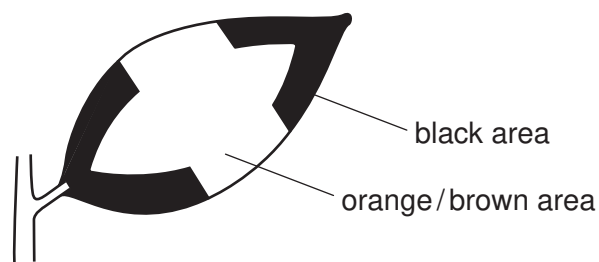

Where has photosynthesis occurred?

- A all areas covered by black paper
 - B all areas not covered by black paper
 - C green areas covered by black paper
 - D green areas not covered by black paper
- 4 Which part of the gut is in the form of a coiled tube?
- A large intestine
 - B oesophagus
 - C rectum
 - D small intestine
- 5 In a balanced diet, which constituents provide most energy?
- A carbohydrate and protein
 - B fat and carbohydrate
 - C fat and fibre
 - D vitamins and protein

- 6 The graph shows changes in his rate of breathing as a boy first walks on the level to the top of a long stair and then walks on the level again.

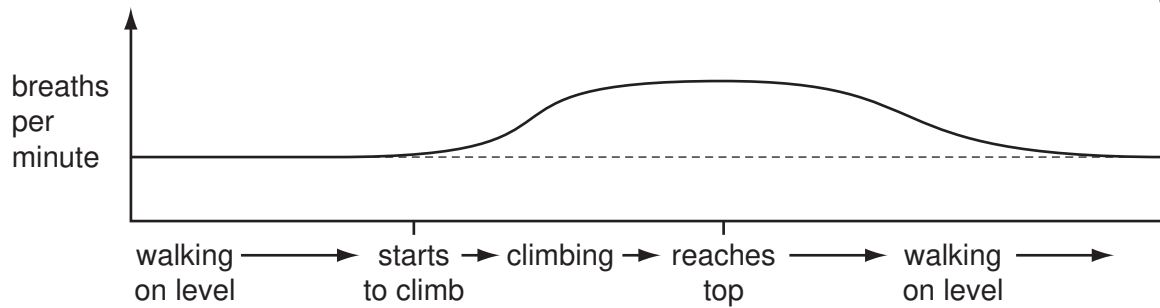

Why does his breathing continue for a while at the higher rate after he reaches the top of the stairs?

- A** He is oxidising lactic acid.
B He still needs more energy.
C His breathing muscles respond slowly.
D More glucose is being used up.
- 7 What would be the effect on the blood of an over-secretion of insulin?
- A** high levels of glucose
B high levels of urea
C low levels of glucose
D low levels of urea
- 8 The diagram shows a person holding an apple.

If the person decides to lift the apple, which labelled part is the effector?

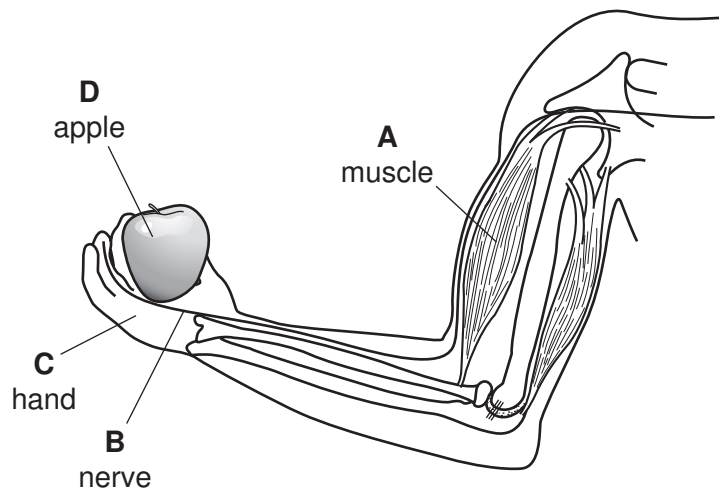

- 9 The diagram shows a flower whose stamens are dying.

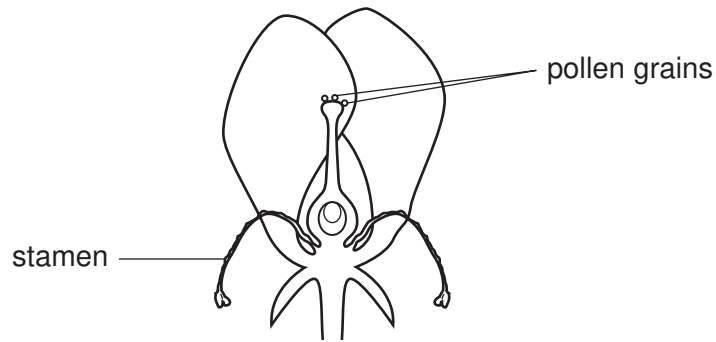

Which process has occurred in this flower?

- A fruit formation
 - B pollination
 - C seed formation
 - D wind dispersal
- 10 The diagram shows a human embryo inside a uterus.

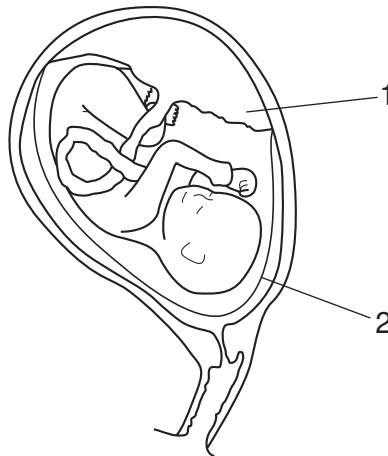

What are the functions of the numbered parts?

	1	2
A	hold the embryo in place	make blood for the embryo
B	protect the embryo	remove waste
C	provide food	provide food
D	remove waste	protect the embryo

11 The allele for red hair is recessive.

If a girl has red hair, which statement about her parents must be correct?

- A Both parents must carry a recessive allele.
- B Both parents must have red hair.
- C One parent must carry a dominant allele.
- D The father must have red hair.

12 The diagram shows a food chain.

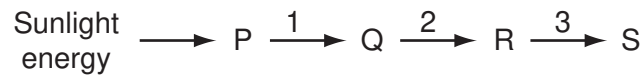

Where do energy losses occur?

- A 1 only
- B 1 and 2 only
- C 2 and 3 only
- D 1, 2 and 3

13 The diagram shows a simple carbon cycle.

Which line should have an arrowhead at both ends?

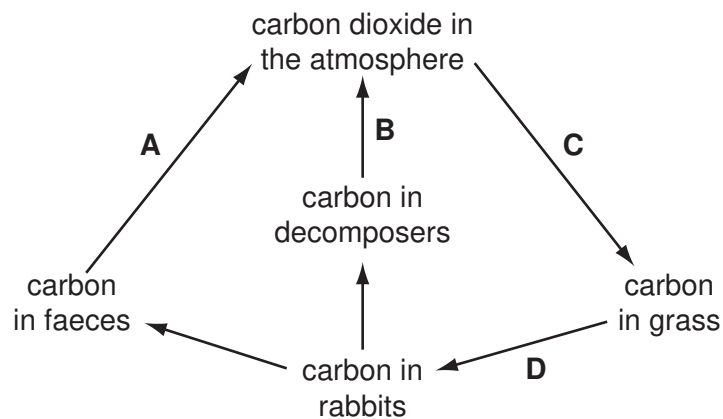

- 14 The graph shows the changes in temperature when a substance is cooled.

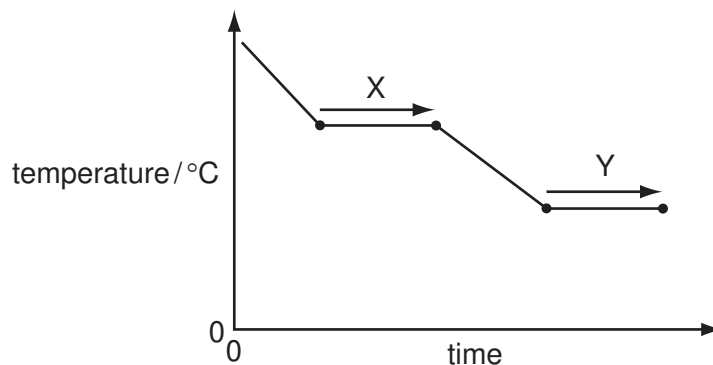

Which row in the table describes X and Y?

	X	Y
A	boiling	freezing
B	boiling	melting
C	condensing	freezing
D	condensing	melting

- 15 Which property of an element suggests that it is a metal?

- A** It conducts electricity.
- B** It forms covalent compounds.
- C** It has a low density.
- D** It has a low melting point.

- 16 What is an important use of the diesel fraction obtained from crude oil?

- A** fuel for lorries and buses
- B** lubricant for door hinges
- C** propellant gas for spray cans
- D** wax for waterproofing car bodies

- 17 Which material is combined with a metal oxide to make glass?

- A** carbon
- B** carbon dioxide
- C** silicon
- D** silicon(IV) oxide

18 The table shows the name and formula of four metal ores.

	name	formula
1	chalcopyrite	CuFeS_2
2	ilmenite	FeTiO_3
3	malachite	$\text{Cu}_2\text{CO}_3(\text{OH})_2$
4	wolframite	FeWO_4

Which metal ores contain two different metals?

- A 1 and 3 only
- B 2 and 4 only
- C 1, 2 and 4 only
- D 2, 3 and 4 only

19 When concentrated salt solution is electrolysed, two gases X and Y are formed.

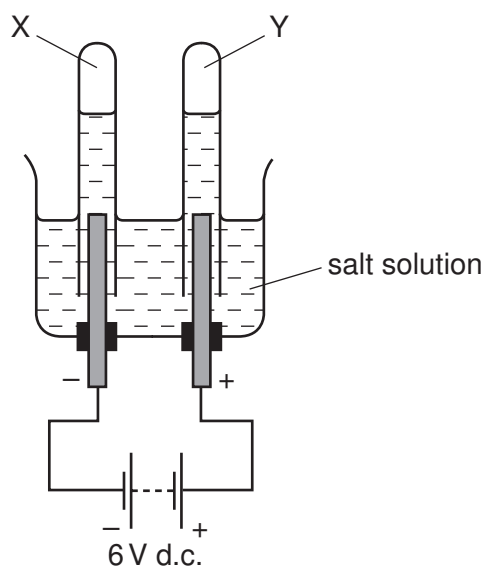

One of the gases explodes when tested with a burning splint and the other turns moist Universal Indicator paper red then white.

What are X and Y?

	X	Y
A	chlorine	hydrogen
B	hydrogen	chlorine
C	hydrogen	oxygen
D	oxygen	chlorine

20 During the weathering of rocks, which process does **not** take place?

- A chemical change
- B fixation of nitrogen
- C physical change
- D release of salts into the soil

21 Ammonium sulfate is heated with solution X and ammonia gas is given off.

A piece of moist red litmus paper and a piece of moist blue litmus paper are held in the gas.

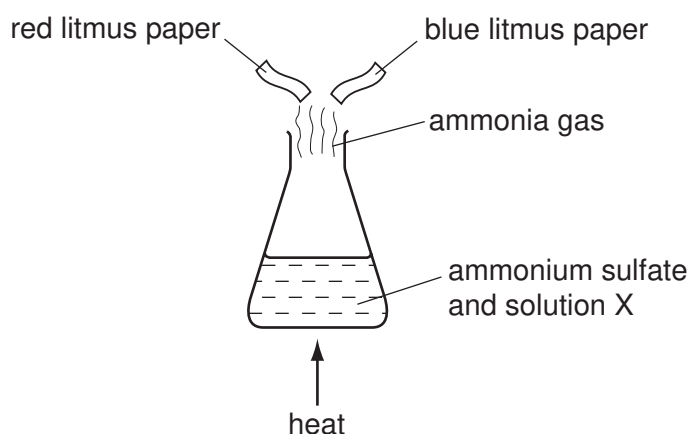

What is solution X and what will be the colour change of the litmus paper?

	solution X	colour change of litmus paper
A	hydrochloric acid	blue to red
B	hydrochloric acid	red to blue
C	sodium hydroxide	blue to red
D	sodium hydroxide	red to blue

22 Chlorophyll is extracted from green plants.

Which method should be used to separate chlorophyll from other coloured substances?

- A chromatography
- B cracking
- C distillation
- D neutralisation

23 The contents of a beaker scatter a beam of light.

What does the beaker contain?

- A aqueous copper(II) sulfate
- B ethanol
- C milk
- D water

24 Nitrogen oxides are formed when car engines burn fossil fuels.

Which row shows why nitrogen oxides are unwanted products?

	acidic	pollutant
A	no	no
B	no	yes
C	yes	no
D	yes	yes

25 The diagram shows an experiment using a lemon.

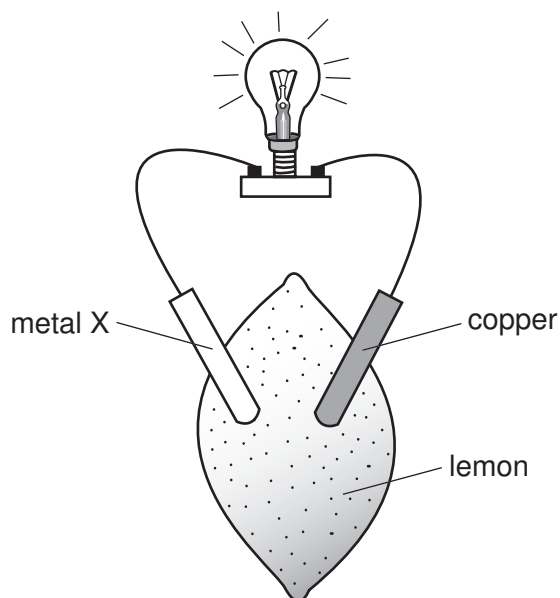

Which statements are correct?

	lemon juice is an electrolyte	X could be copper	X could be zinc
A	✓	✓	✓
B	✓	✓	✗
C	✓	✗	✓
D	✗	✓	✓

26 An aqueous solution of a compound of metal M is tested.

- It does not give a characteristic flame colour.
- It forms a precipitate with aqueous ammonia; the precipitate is soluble in excess ammonia.

What is metal M?

- A** copper
- B** iron
- C** potassium
- D** zinc

- 27 When element X reacts with element Y, X donates an electron to Y.

Which row correctly shows the type of ion that Y forms and how its position in the Periodic Table changes?

	type of ion	effect on position of element Y in Periodic Table
A	negative	moves one place to the right
B	negative	no change
C	positive	moves one place to the right
D	positive	no change

- 28 The cubes shown are made of different materials, but they have the same mass.

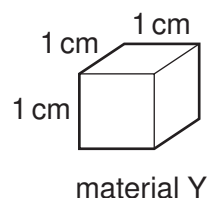
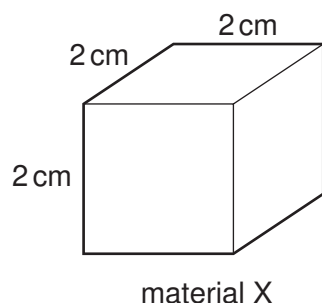

The density of material X is 1 g/cm^3 .

What is the density of material Y?

- A** $\frac{1}{8} \text{ g/cm}^3$ **B** $\frac{1}{2} \text{ g/cm}^3$ **C** 2 g/cm^3 **D** 8 g/cm^3
- 29 The winner of a 1500 m race takes 4 minutes to run the race.

What is his average speed in m/s?

- A** $1500 \times \frac{60}{4}$
- B** $1500 \times 4 \times 60$
- C** $\frac{1500}{4 \times 60}$
- D** $\frac{1500 \times 4}{60}$

- 30 A rod is acted upon by two forces as shown in the diagram.

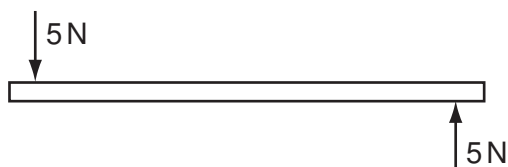

Which effect will be produced by these two forces?

- A** both rotation and movement in a straight line
B rotation only
C no effect, because the forces are balanced
D movement in a straight line only
- 31 The table gives four pairs of values of force and the surface area on which the force acts.

Which pair of values gives the largest pressure on the surface?

	force / N	area / m ²
A	20	2
B	40	2
C	20	4
D	40	4

- 32 Liquid X has a higher specific heat capacity than liquid Y.

What does this mean?

- A** 1 kg of liquid X needs to be given more energy than 1 kg of liquid Y to make it evaporate.
B 1 kg of liquid X releases more energy than 1 kg of liquid Y when it freezes.
C More energy needs to be supplied to 1 kg of liquid X than to 1 kg of liquid Y for their temperatures to rise by the same amount.
D The temperature of 1 kg of liquid X rises more than the temperature of 1 kg of liquid Y when they are given the same amount of energy.
- 33 Which is the correct equation for resistance?
- A** resistance = current \div voltage
B resistance = power \div current
C resistance = power \div voltage
D resistance = voltage \div current

- 34 A householder asks an electrician to install a mains electrical socket in her bathroom. She may use a hairdryer there. The electrician refuses to do this because it would be dangerous.

Why would installing the socket be dangerous?

- A The current drawn by the hairdryer would cause overheating in the cables.
 - B The handling of electrical equipment in damp conditions could cause an electric shock.
 - C The hot air produced by the hairdryer would cause the fuse to melt.
 - D The temperature in the bathroom would damage the insulation.
- 35 A student has four pieces of resistance wire made of the same material. Each piece is connected in turn between the terminals X and Y in the circuit.

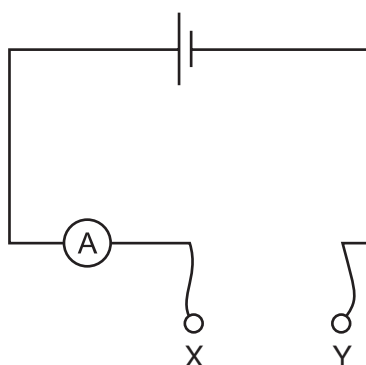

In which wire will the current be the smallest?

	length / m	diameter / mm
A	0.5	0.5
B	0.5	1.0
C	1.0	0.5
D	1.0	1.0

- 36 A stone is thrown into a pool and waves spread out from where it hits the water.

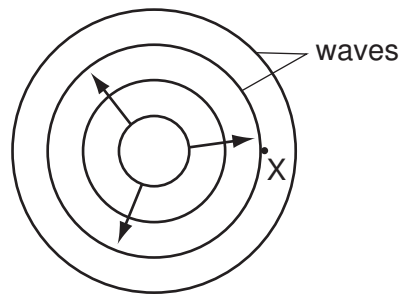

What is the name given to the number of waves passing point X per second?

- A the amplitude
 - B the frequency
 - C the wavelength
 - D the wave speed
- 37 Which ray diagram shows a converging lens producing a real image of object O?

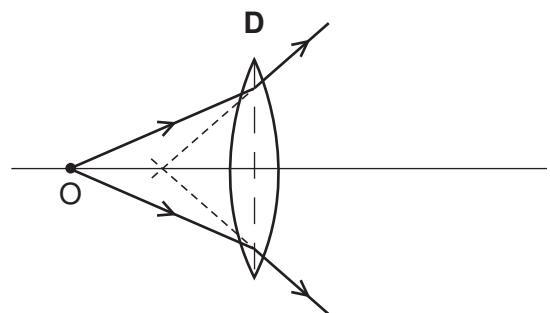
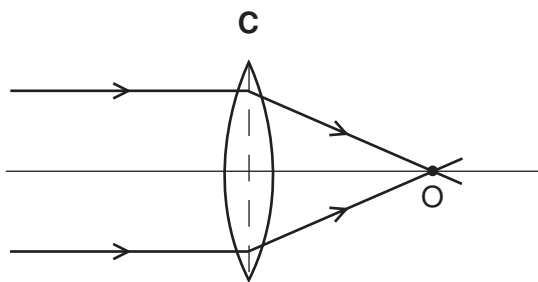
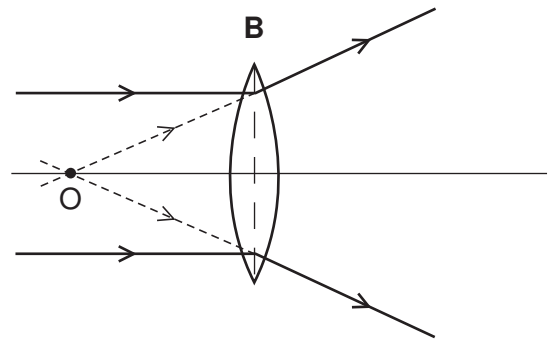
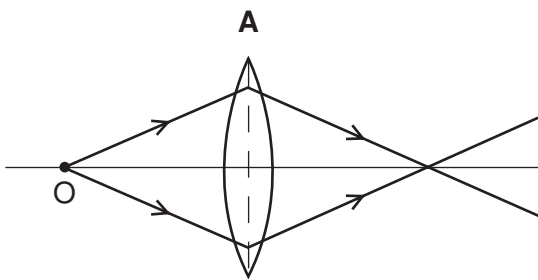

38 A magnet and a charged plastic rod are held near each other.



magnet



charged plastic rod

What happens?

- A Both poles of the magnet attract both ends of the plastic rod.
 - B Neither pole of the magnet attracts either end of the plastic rod.
 - C Only the north pole of the magnet attracts the positive end of the plastic rod.
 - D Only the south pole of the magnet attracts the positive end of the plastic rod.
- 39 Which statement about radioactive emissions is correct?
- A Alpha-particles are the least penetrating and are positively charged.
 - B Alpha-particles are the most penetrating and are positively charged.
 - C Gamma-rays are the least penetrating and are positively charged.
 - D Gamma-rays are the most penetrating and are positively charged.
- 40 A sample of radioactive material has a mass of 64 mg and a half-life of 16 years.
- What is the time taken for the mass of the sample to decrease to 8 mg?
- A 2 years
 - B 4 years
 - C 48 years
 - D 128 years

DATA SHEET

The Periodic Table of the Elements

Group																					
I	II											III	IV	V	VI	VII	0				
										1 H Hydrogen 1											4 He Helium 2
7 Li Lithium 3	9 Be Beryllium 4											11 B Boron 5	12 C Carbon 6	14 N Nitrogen 7	16 O Oxygen 8	19 F Fluorine 9	20 Ne Neon 10				
23 Na Sodium 11	24 Mg Magnesium 12											27 Al Aluminium 13	28 Si Silicon 14	31 P Phosphorus 15	32 S Sulfur 16	35.5 Cl Chlorine 17	40 Ar Argon 18				
39 K Potassium 19	40 Ca Calcium 20	45 Sc Scandium 21	48 Ti Titanium 22	51 V Vanadium 23	52 Cr Chromium 24	55 Mn Manganese 25	56 Fe Iron 26	59 Co Cobalt 27	59 Ni Nickel 28	64 Cu Copper 29	65 Zn Zinc 30	70 Ga Gallium 31	73 Ge Germanium 32	75 As Arsenic 33	79 Se Selenium 34	80 Br Bromine 35	84 Kr Krypton 36				
85 Rb Rubidium 37	88 Sr Strontium 38	89 Y Yttrium 39	91 Zr Zirconium 40	93 Nb Niobium 41	96 Mo Molybdenum 42	96 Tc Technetium 43	101 Ru Ruthenium 44	103 Rh Rhodium 45	106 Pd Palladium 46	108 Ag Silver 47	112 Cd Cadmium 48	115 In Indium 49	119 Sn Tin 50	122 Sb Antimony 51	128 Te Tellurium 52	127 I Iodine 53	131 Xe Xenon 54				
133 Cs Caesium 55	137 Ba Barium 56	139 La Lanthanum 57 *	178 Hf Hafnium 72	181 Ta Tantalum 73	184 W Tungsten 74	186 Re Rhenium 75	190 Os Osmium 76	192 Ir Iridium 77	195 Pt Platinum 78	197 Au Gold 79	201 Hg Mercury 80	204 Tl Thallium 81	207 Pb Lead 82	209 Bi Bismuth 83	209 Po Polonium 84	209 At Astatine 85	209 Rn Radon 86				
87 Fr Francium	226 Ra Radium	227 Ac Actinium †																			

*58-71 Lanthanoid series

†90-103 Actinoid series

a	a = relative atomic mass
X	X = atomic symbol
b	b = proton (atomic) number

140 Ce Cerium 58	141 Pr Praseodymium 59	144 Nd Neodymium 60	Pm Promethium 61	150 Sm Samarium 62	152 Eu Europium 63	157 Gd Gadolinium 64	159 Tb Terbium 65	162 Dy Dysprosium 66	165 Ho Holmium 67	167 Er Erbium 68	169 Tm Thulium 69	173 Yb Ytterbium 70	175 Lu Lutetium 71
232 Th Thorium 90	238 Pa Protactinium 91	238 U Uranium 92	Np Neptunium 93	Pu Plutonium 94	Am Americium 95	Cm Curium 96	Bk Berkelium 97	Cf Californium 98	Es Einsteinium 99	Fm Fermium 100	Md Mendelevium 101	No Nobelium 102	Lr Lawrencium 103

The volume of one mole of any gas is 24 dm³ at room temperature and pressure (r.t.p.).

Permission to reproduce items where third-party owned material protected by copyright is included has been sought and cleared where possible. Every reasonable effort has been made by the publisher (UCLES) to trace copyright holders, but if any items requiring clearance have unwittingly been included, the publisher will be pleased to make amends at the earliest possible opportunity.

University of Cambridge International Examinations is part of the Cambridge Assessment Group. Cambridge Assessment is the brand name of University of