



UNIVERSITY OF CAMBRIDGE INTERNATIONAL EXAMINATIONS
International General Certificate of Secondary Education

CANDIDATE
NAME

CENTRE
NUMBER

--	--	--	--	--

CANDIDATE
NUMBER

--	--	--	--

* 0 9 8 3 6 1 9 8 7 9 *

CO-ORDINATED SCIENCES

0654/22

Paper 2 (Core)

May/June 2011

2 hours

Candidates answer on the Question Paper.

No Additional Materials are required.

READ THESE INSTRUCTIONS FIRST

Write your Centre number, candidate number and name on all the work you hand in.

Write in dark blue or black pen.

You may use a soft pencil for any diagrams, graphs, tables or rough working.

Do not use staples, paper clips, highlighters, glue or correction fluid.

DO NOT WRITE IN ANY BARCODES.

Answer **all** questions.

A copy of the Periodic Table is printed on page 28.

At the end of the examination, fasten all your work securely together.

The number of marks is given in brackets [] at the end of each question or part question.

For Examiner's Use	
1	
2	
3	
4	
5	
6	
7	
8	
9	
10	
Total	

This document consists of **27** printed pages and **1** blank page.



- 1 Fig. 1.1 shows layers of sedimentary rocks lying under the sea bed near a coast. The diagram is not drawn to scale.

Some of these rock layers are permeable and contain fossil fuels trapped inside them.

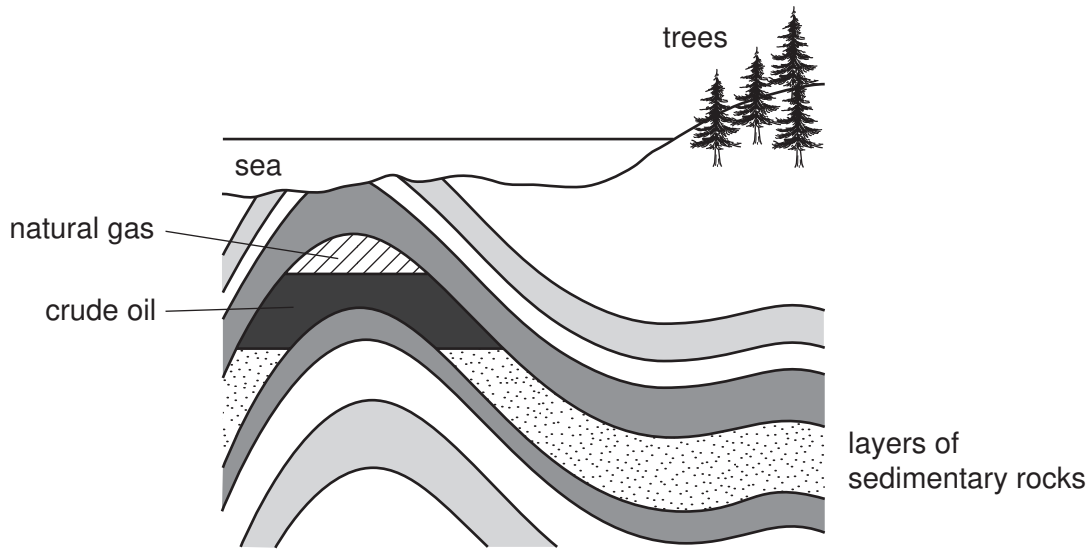

Fig. 1.1

- (a) (i) Wood obtained from trees and compounds obtained from crude oil and natural gas can be used as fuels.

State **two** reasons why crude oil and natural gas are examples of *fossil fuels* but wood is not.

1

.....

2

..... [2]

- (ii) Fossil fuels contain mainly hydrocarbons. Wood contains cellulose which is a carbohydrate.

Name an element which is combined in carbohydrate molecules but **not** in hydrocarbons.

..... [1]

(iii) Plants produce both glucose and cellulose.

Describe briefly how cellulose molecules are formed from glucose molecules.

.....
.....
..... [2]

(b) The molecular formulae of three hydrocarbon molecules are shown below.

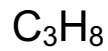
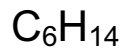

Suggest and explain briefly which **one** of these formulae is of a hydrocarbon **least** likely to be found in natural gas.

formula

explanation

..... [1]

- (c) In a car engine, the combustion of hydrocarbons produces a mixture of very hot (exhaust) gases.

These gases are released from the car into the atmosphere, and some of them cause pollution because they are poisonous.

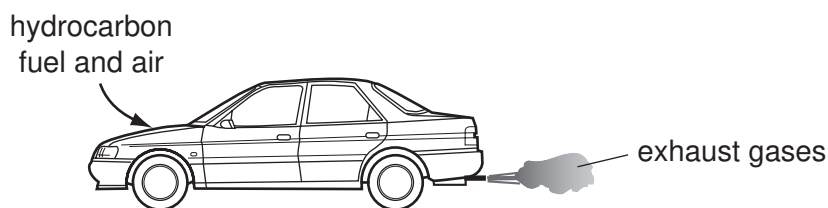

Some of the gases in a car's exhaust are listed in Table 1.1.

Table 1.1

substance in exhaust gases
carbon dioxide
carbon monoxide
nitrogen
nitrogen dioxide
oxygen
water vapour

- (i) Write the names of gases chosen from Table 1.1 which match the following descriptions.

unreactive element which makes up most of the atmosphere

.....

condenses when cooled to form a colourless liquid compound

..... [2]

(ii) Suggest how a sample of the exhaust gases from a car could be tested to detect the presence of carbon dioxide.

.....
.....
..... [2]

(iii) **Two** of the gases in Table 1.1 are hazardous air pollutants because even small amounts can have harmful effects on humans who inhale them.

Name these hazardous air pollutants.

1
2 [2]

- 2 (a) A builder does 8000 J of work in ten minutes.

Calculate the average power he produces.

State the formula that you use and show your working.

State the units in your answer.

formula used

working

..... [3]

- (b) A brick falls from a crane on a building site. It hits the ground at a speed of 40 m/s. The air resistance on the brick can be ignored.

- (i) The brick has a mass of 2 kg.

Calculate the kinetic energy of the brick as it hits the ground.

State the formula that you use and show your working.

formula used

working

..... J [2]

(ii) State the value for the potential energy of the brick before it fell from the crane.

Explain your answer.

potential energy J

explanation

..... [2]

(c) Fig. 2.1 shows the structure of the walls of a house in a cold climate.

Heat can escape through the walls of the house. Explain how the structure of the wall in Fig. 2.1 reduces heat loss.

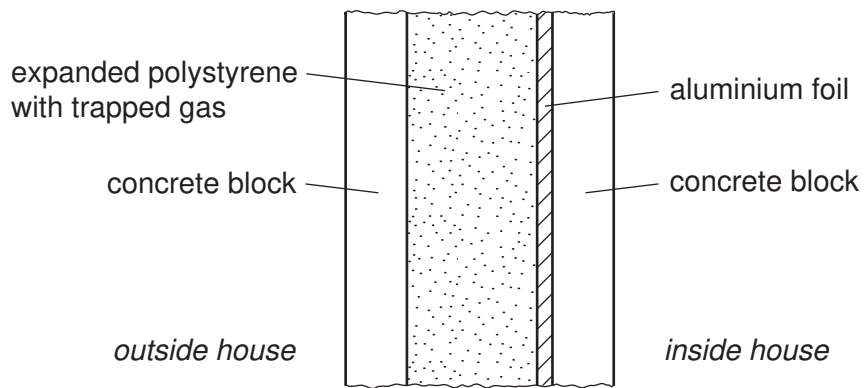

Fig. 2.1

.....

.....

.....

.....

.....

.....

..... [3]

- 3 Fig. 3.1 shows some of the bones and muscles in the human arm.

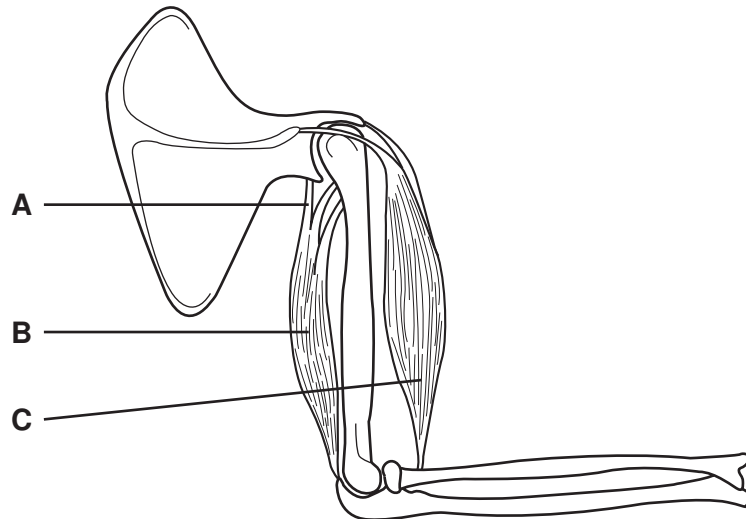

Fig. 3.1

- (a) (i) Name the structures labelled **B** and **C**.

B

C [2]

- (ii) State how each of these structures, shown in Fig. 3.1, helps to cause the arm to straighten.

structure **B**

structure **A**

structure **C** [3]

(b) Bone contains the mineral calcium phosphate.

A study was carried out in Brazil into the mineral content of the leg bones of school children between the ages of 10 and 19 years. The mineral content was measured as the mass of mineral per cm³ of bone. Some of the results are shown in Fig. 3.2.

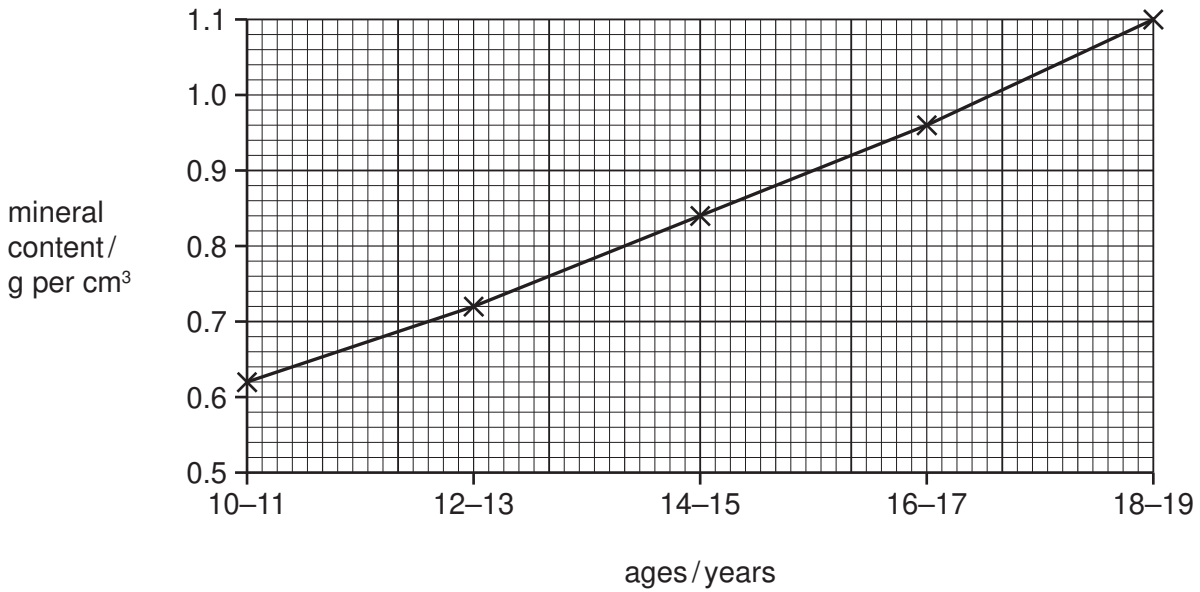

Fig. 3.2

(i) Describe how the mineral content of bone changes between the ages of 10 and 19 years.

.....
.....
..... [2]

(ii) Suggest why a teenager should have a diet containing plenty of dairy products such as milk and cheese.

.....
.....
..... [2]

(iii) Bone also contains a protein called collagen. Vitamin C is required to make collagen.

Name **one** food that contains large amounts of vitamin C.

..... [1]

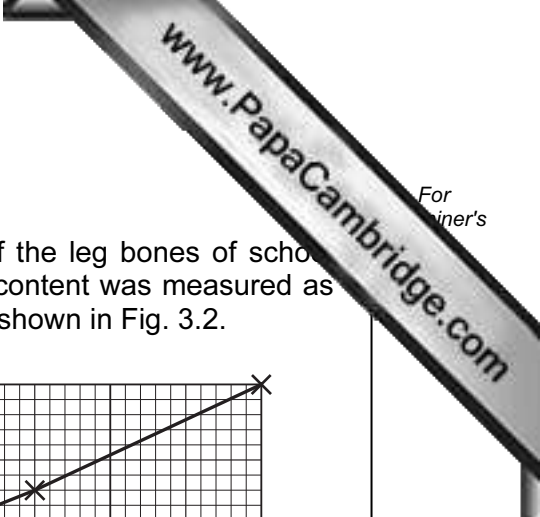

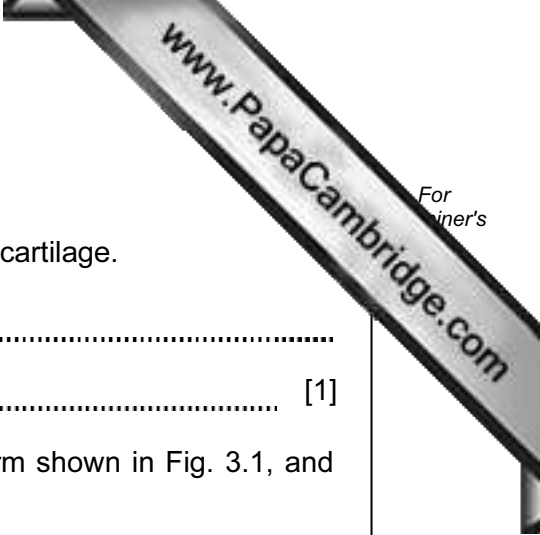

(c) Some parts of the human skeleton are made of cartilage.

(i) State **one** difference between the properties of bone and cartilage.

.....
..... [1]

(ii) State precisely where cartilage is found in the human arm shown in Fig. 3.1, and describe its function.

.....
.....
..... [2]

Please turn over for Question 4.

4 (a) Fig. 4.1 shows a skier being pulled up a mountain slope by a cable (lift).

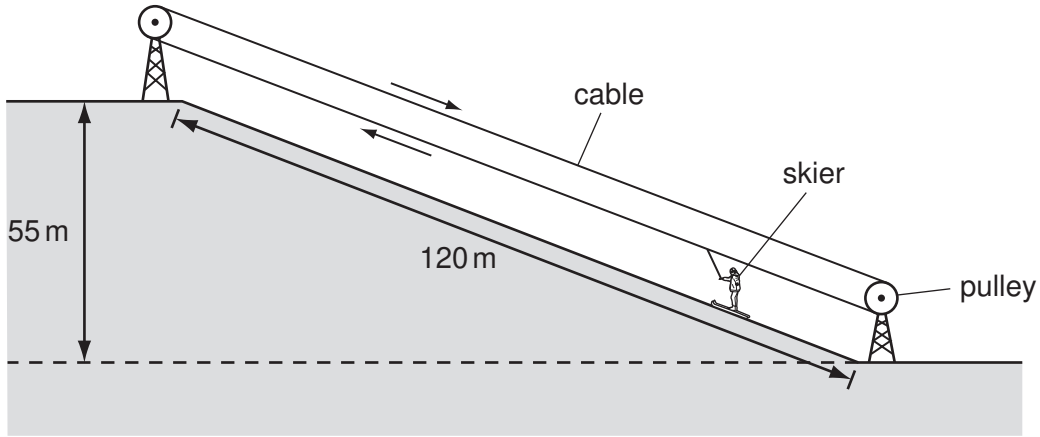

Fig. 4.1

The skier weighs 700 N. She travels 120 m along the slope and rises by a vertical height of 55 m.

Calculate the work done lifting the skier from the bottom to the top of the slope. You should ignore the work done against friction.

State the formula that you use and show your working.

formula used

working

..... J [2]

(b) Fig. 4.2 shows the speed-time graph for a skier competing in a race.

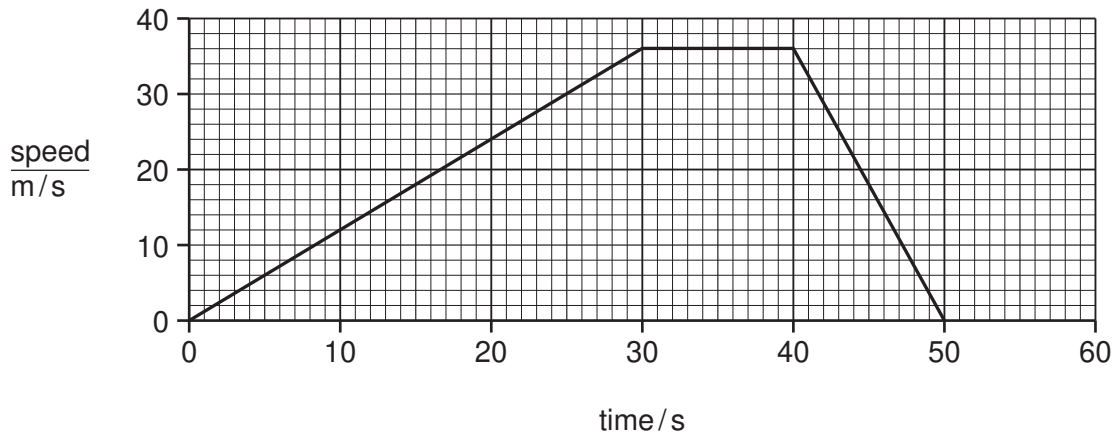

Fig. 4.2

(i) State the length of time the skier was moving.

..... [1]

(ii) Describe the motion of the skier between 30 and 40 seconds.

.....
..... [2]

- (c) Skiers use a ski pole in each hand to help control their motion. The ski poles work when they only go into the snow for a few centimetres.

Fig. 4.3 shows a skier using ski poles.

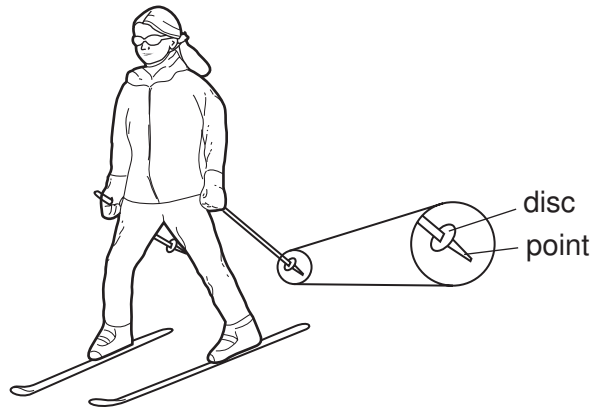

Fig 4.3

Explain, in terms of pressure, force and area, why the ski pole has a pointed end and a large disc a few centimetres above this.

.....
.....
..... [2]

- (d) Explain why a skier keeps the lower surface of her skis smooth and well polished.

.....
..... [1]

- 5 Guanacos are relatives of camels and live in the Andes mountains in South America. They feed on grasses and other plants. They are hunted by pumas, and young guanacos may be killed by foxes.

Fig. 5.1 shows a guanaco.



Fig. 5.1

- (a) (i) State **one** feature, visible on Fig. 5.1, that indicates that guanacos are mammals.

..... [1]

- (ii) State **one** feature, visible on Fig. 5.1, that could help guanacos to avoid being killed by pumas.

..... [1]

- (b) Guanacos can live at very high altitudes, above 4000 metres, where there is less oxygen in the air than at sea level.

- (i) Describe how oxygen from the air enters the blood of a mammal, such as a guanaco.

.....

 [2]

- (ii) The blood of a guanaco contains four times as many red blood cells per cm³ of blood of a human.

This helps the guanaco to adapt to its environment. Suggest an explanation for this.

.....
.....
..... [2]

- (c) Guanacos are an endangered species. Their numbers have fallen because of loss of suitable habitat and because of hunting by humans. Several countries in South America have conservation programmes to try to increase the numbers of guanacos.

In one conservation programme, five male and five female guanacos were introduced into a suitable habitat of about 25 km². They were protected from humans.

Fig. 5.2 shows what happened to the guanaco population over the next few years.

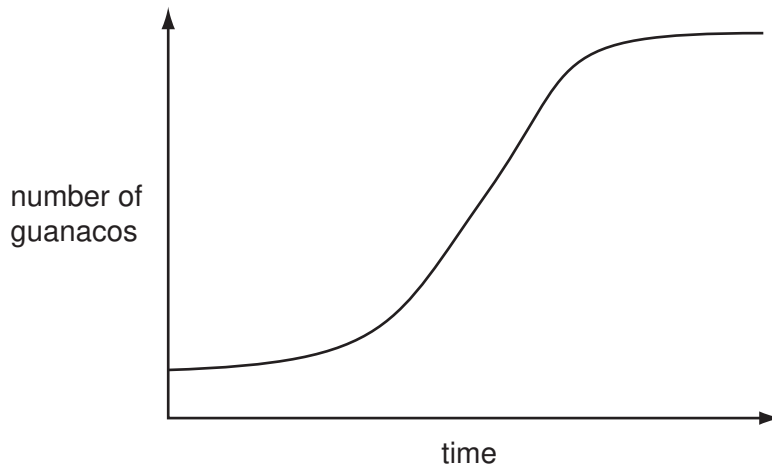
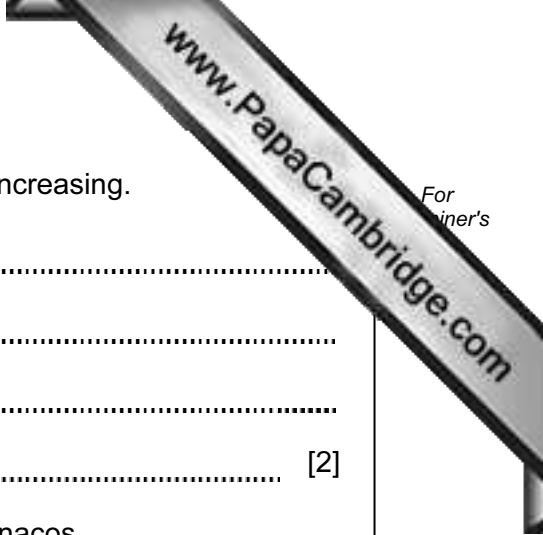

Fig. 5.2



(i) Explain why the guanaco population eventually stopped increasing.

.....
.....
.....
..... [2]

(ii) Suggest **two** reasons why it is important to conserve guanacos.

1
.....
2
..... [2]

6 Lithium and its compounds have many important uses.

(a) (i) State the group number and period number of lithium in the Periodic Table.

group number

period number

[1]

(ii) Fig. 6.1 shows how pieces of lithium metal are stored.

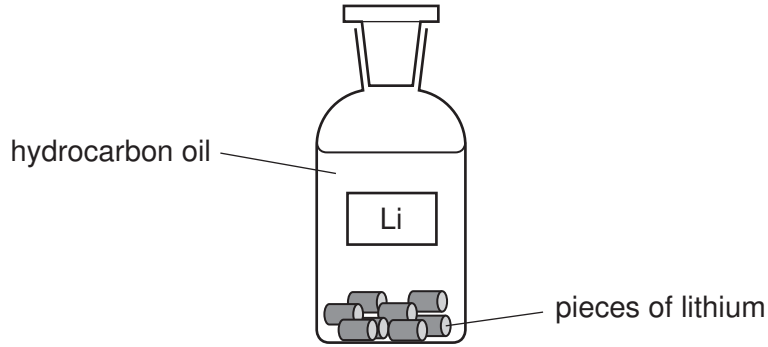

Fig. 6.1

State and explain why it is necessary to store lithium in this way.

.....

.....

..... [2]

(iii) Fig. 6.2 shows a student's attempt to draw the arrangement of all the electrons in a lithium atom.

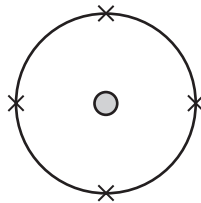

Fig. 6.2

State **two** mistakes that the student has made.

1

.....

2

..... [2]

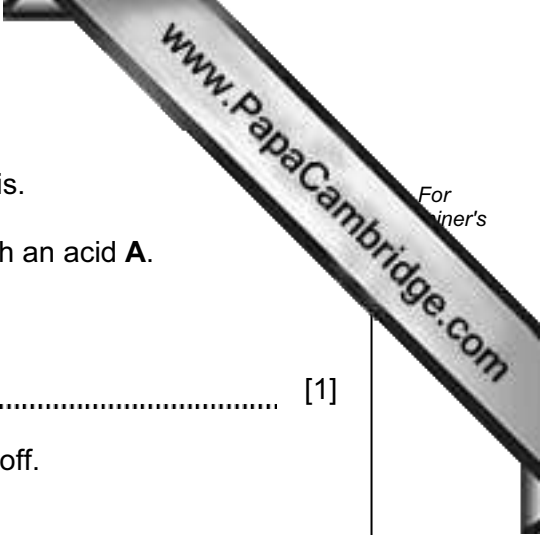

(b) Lithium is extracted from the salt lithium chloride by electrolysis.

Lithium chloride is first made by reacting lithium carbonate with an acid **A**.

(i) Suggest the name of acid **A**.

..... [1]

(ii) When acid **A** reacts with lithium carbonate a gas is given off.

Name this gas.

..... [1]

(iii) Complete the word equation below which describes the electrolysis of lithium chloride.

lithium chloride → lithium + [1]

(c) Lithium carbonate is widely used as a drug to treat some types of mental illness.

(i) State the general meaning of the term *drug*.

.....
..... [1]

(ii) It is very important that compounds for use as drugs are made to high standards of purity.

State **one** important reason for this requirement.

.....
..... [1]

- 7 (a) Optical fibres are used to see inside the human body. Light is sent along some fibres to enable doctors to see what is there.

Fig. 7.1 shows an optical fibre with a ray of light travelling down part of it.

Draw the path of the ray of light as it travels down the fibre.

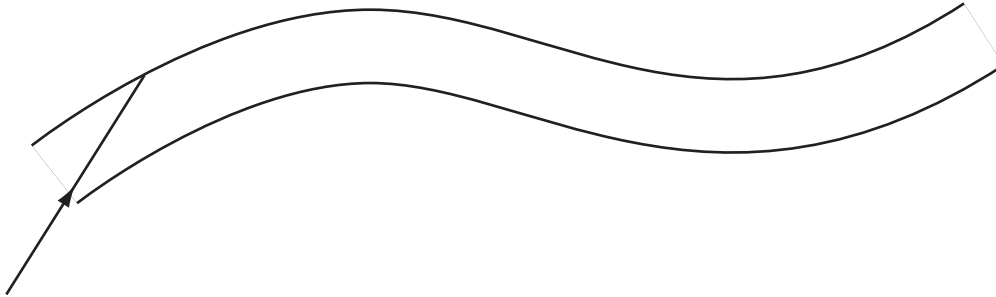

Fig. 7.1

[2]

- (b) A doctor wants to use a small torch to look down a patient's throat.

The torch does not work.

Fig. 7.2 shows the circuit diagram for the torch.

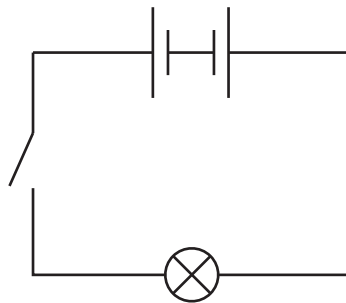
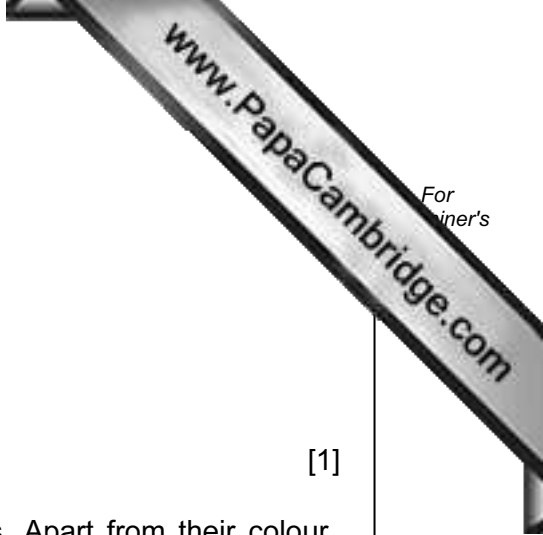

Fig. 7.2

Draw the correct circuit diagram to make the torch work.

[1]



(c) Human eyes are able to detect the three primary colours.

(i) Name these colours.

1

2

3

[1]

(ii) These three colours of light are electromagnetic waves. Apart from their colour, state **one** other way in which they differ from each other.

.....

..... [1]

8 Many plants can reproduce sexually. The parts of a plant that carry out sexual reproduction are the flowers.

(a) Name the part of a flower that carries out each of the following functions.

- (i) attracts insects to the flower [1]
- (ii) makes pollen [1]
- (iii) contains the female gametes [1]

(b) Explain the differences between *pollination* and *fertilisation*.

.....
.....
.....
..... [2]

(c) The cells of a sunflower plant contain 34 chromosomes.

- (i) How many chromosomes will there be in a male gamete of a sunflower?
..... [1]
- (ii) State the part of a cell in which chromosomes are found.
..... [1]
- (iii) Name the chemical that stores coded instructions in chromosomes.
..... [1]

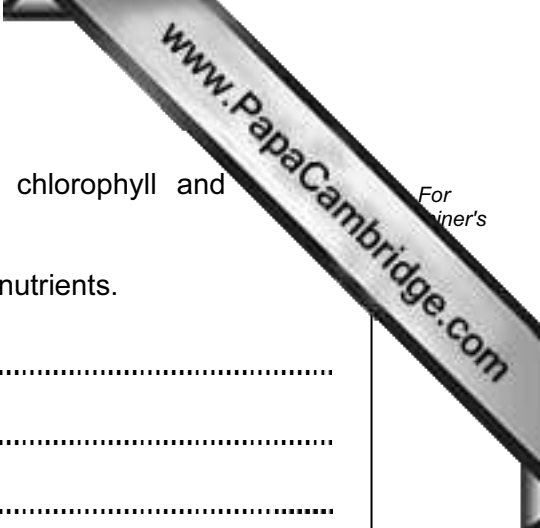

(d) The cells in the petals of most flowers do not contain chlorophyll and photosynthesise.

(i) Suggest how the cells in flowers obtain sugars and other nutrients.

.....
.....
.....
..... [2]

(ii) Suggest **one** reason why cells in flowers need sugars.

..... [1]

- 9 A student investigated the reactivity of four metals **A**, **B**, **C** and **D**, by comparing the which these metals reacted in dilute acid.

Fig. 9.1 shows what the student observed during the experiment.

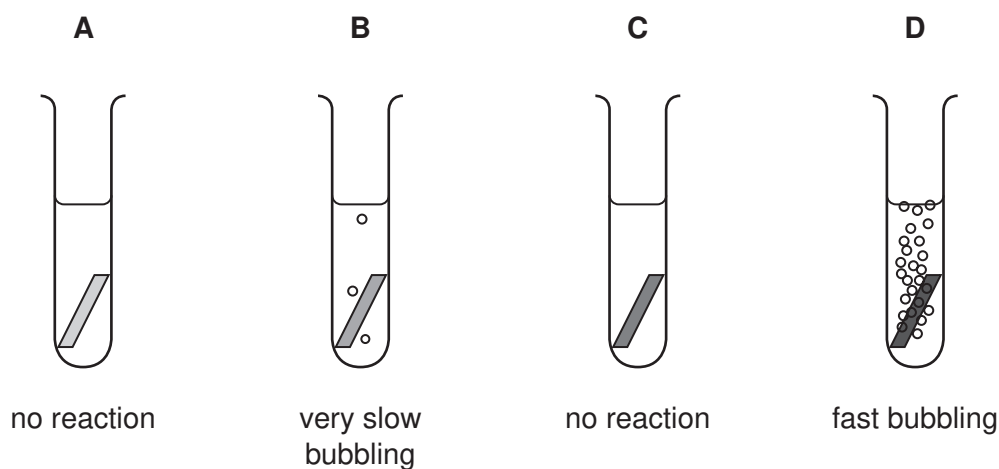

Fig. 9.1

- (a) (i) State **three** variables (experimental conditions) that the student must keep the same if her assessment of the relative reactivity of the four metals is to be reliable.

1

2

3 [3]

- (ii) Predict and explain what would be observed if a lighted splint is held in the mouth of the test-tube in which metal **D** is reacting.

.....

.....

..... [2]

- (iii) Explain briefly why the student's observations did **not** allow her to place all four metals into order based on their reactivity.

.....

..... [1]

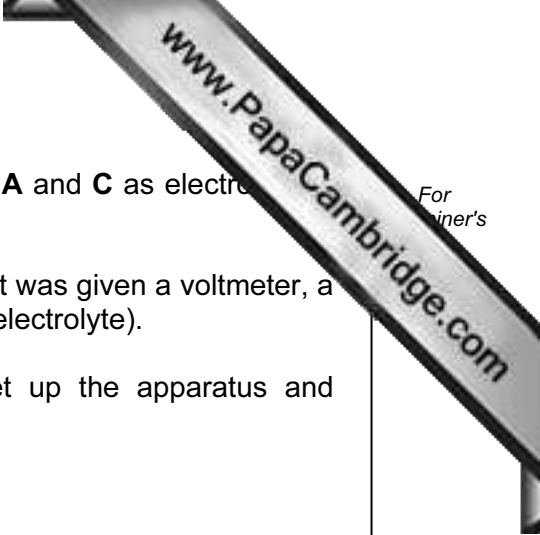

- (b) The student was asked to use some larger pieces of metals **A** and **C** as electrodes to set up an electrochemical cell.

In addition to the electrodes and connecting wires, the student was given a voltmeter, a beaker and a bottle containing potassium nitrate solution (an electrolyte).

- (i) Draw a diagram to show how the student should set up the apparatus and materials to produce an electrochemical cell.

[3]

- (ii) The student successfully set up the electrochemical cell using metals **A** and **C** as electrodes. She measured the voltage of this cell.

She then replaced the electrode made of metal **A** by one made of metal **B**.

State and explain the effect, if any, that this had on the electrochemical cell.

.....

.....

..... [2]

10 (a) Nuclear reactors in power stations released energy through nuclear fission.

- (i) Plutonium is a fuel used in nuclear reactors. Another element used as nuclear fuel has the symbol U.

Name this element. [1]

- (ii) Using words from the list below, complete the flow chart to show the stages of generating electrical energy in a nuclear power station.

energy generator nuclear nuclei turbine

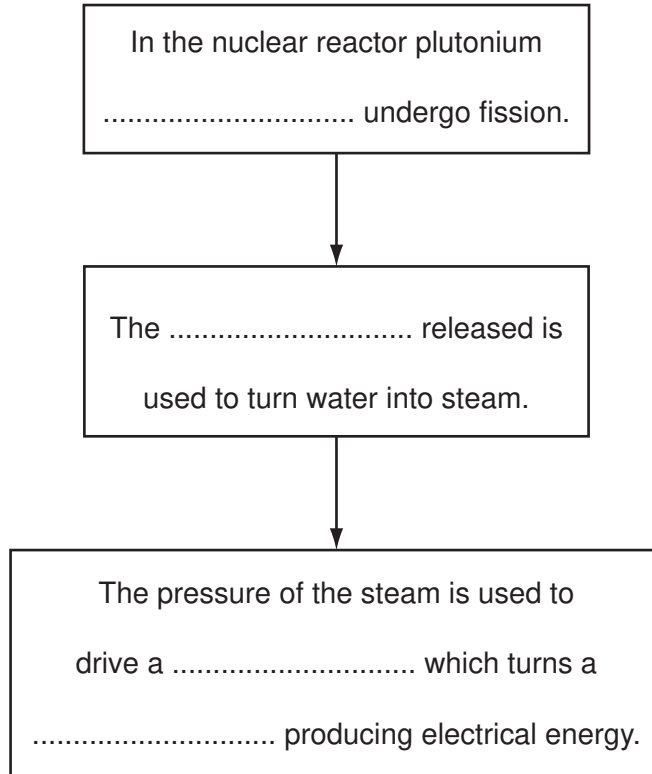

[3]

(b) A nuclear reactor can also be used to power a submarine.

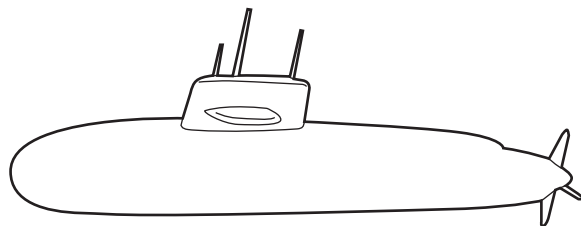

Radiation is released during nuclear fission. The reactor has to be shielded to protect the crew from this radiation.

(i) Suggest **one** material which could shield a nuclear reactor to stop radiation escaping.

..... [1]

(ii) Describe how exposure to ionising radiation can affect the human body.

.....
.....
..... [2]

(c) Waste from a nuclear reactor contains radioactive material with a half-life of 100 years.

A sample of this material gives a count rate of 3200 counts per minute.

(i) What instrument could be used to measure the count rate?

..... [1]

(ii) Calculate the time taken for the count rate to drop to 400 counts per minute.

Show your working.

..... years [2]

DATA SHEET

The Periodic Table of the Elements

Group																				
I	II											III	IV	V	VI	VII	0			
												1 H Hydrogen 1								4 He Helium 2
7 Li Lithium 3	9 Be Beryllium 4											11 B Boron 5	12 C Carbon 6	14 N Nitrogen 7	16 O Oxygen 8	19 F Fluorine 9	20 Ne Neon 10			
23 Na Sodium 11	24 Mg Magnesium 12											27 Al Aluminium 13	28 Si Silicon 14	31 P Phosphorus 15	32 S Sulfur 16	35.5 Cl Chlorine 17	40 Ar Argon 18			
39 K Potassium 19	40 Ca Calcium 20	45 Sc Scandium 21	48 Ti Titanium 22	51 V Vanadium 23	52 Cr Chromium 24	55 Mn Manganese 25	56 Fe Iron 26	59 Co Cobalt 27	59 Ni Nickel 28	64 Cu Copper 29	65 Zn Zinc 30	70 Ga Gallium 31	73 Ge Germanium 32	75 As Arsenic 33	79 Se Selenium 34	80 Br Bromine 35	84 Kr Krypton 36			
85 Rb Rubidium 37	88 Sr Strontium 38	89 Y Yttrium 39	91 Zr Zirconium 40	93 Nb Niobium 41	96 Mo Molybdenum 42	98 Tc Technetium 43	101 Ru Ruthenium 44	103 Rh Rhodium 45	106 Pd Palladium 46	108 Ag Silver 47	112 Cd Cadmium 48	115 In Indium 49	119 Sn Tin 50	122 Sb Antimony 51	128 Te Tellurium 52	127 I Iodine 53	131 Xe Xenon 54			
133 Cs Caesium 55	137 Ba Barium 56	139 La Lanthanum 57	178 Hf Hafnium 72	181 Ta Tantalum 73	184 W Tungsten 74	186 Re Rhenium 75	190 Os Osmium 76	192 Ir Iridium 77	195 Pt Platinum 78	197 Au Gold 79	201 Hg Mercury 80	204 Tl Thallium 81	207 Pb Lead 82	209 Bi Bismuth 83	210 Po Polonium 84	210 At Astatine 85	210 Rn Radon 86			
87 Fr Francium	88 Ra Radium	89 Ac Actinium †																		

*58-71 Lanthanoid series
†90-103 Actinoid series

Key

a	X	a = relative atomic mass
b		b = proton (atomic) number

140 Ce Cerium 58	141 Pr Praseodymium 59	144 Nd Neodymium 60	147 Pm Promethium 61	150 Sm Samarium 62	152 Eu Europium 63	157 Gd Gadolinium 64	159 Tb Terbium 65	162 Dy Dysprosium 66	165 Ho Holmium 67	167 Er Erbium 68	169 Tm Thulium 69	173 Yb Ytterbium 70	175 Lu Lutetium 71
232 Th Thorium 90	234 Pa Protactinium 91	238 U Uranium 92	238 Np Neptunium 93	244 Pu Plutonium 94	247 Am Americium 95	251 Cm Curium 96	257 Bk Berkelium 97	261 Cf Californium 98	265 Es Einsteinium 99	267 Fm Fermium 100	271 Md Mendelevium 101	277 No Nobelium 102	289 Lr Lawrencium 103

The volume of one mole of any gas is 24 dm³ at room temperature and pressure (r.t.p.).

Permission to reproduce items where third-party owned material protected by copyright is included has been sought and cleared where possible. Every reasonable effort has been made by the publisher (UCLES) to trace copyright holders, but if any items requiring clearance have unwittingly been included, the publisher will be pleased to make amends at the earliest possible opportunity.

University of Cambridge International Examinations is part of the Cambridge Assessment Group. Cambridge Assessment is the brand name of University of