



UNIVERSITY OF CAMBRIDGE INTERNATIONAL EXAMINATIONS  
International General Certificate of Secondary Education

www.PapaCambridge.com

**CO-ORDINATED SCIENCES**

**0654/12**

Paper 1 Multiple Choice

**May/June 2012**

**45 minutes**

Additional Materials: Multiple Choice Answer Sheet  
Soft clean eraser  
Soft pencil (type B or HB is recommended)

\* 5 1 1 3 2 4 4 8 5 7 \*

**READ THESE INSTRUCTIONS FIRST**

Write in soft pencil.

Do not use staples, paper clips, highlighters, glue or correction fluid.

Write your name, Centre number and candidate number on the Answer Sheet in the spaces provided unless this has been done for you.

There are **forty** questions on this paper. Answer **all** questions. For each question there are four possible answers **A, B, C** and **D**.

Choose the **one** you consider correct and record your choice in **soft pencil** on the separate Answer Sheet.

**Read the instructions on the Answer Sheet very carefully.**

Each correct answer will score one mark. A mark will not be deducted for a wrong answer.

Any rough working should be done in this booklet.

A copy of the Periodic Table is printed on page 20.

This document consists of **17** printed pages and **3** blank pages.



- 1 The diagram shows an incomplete plant cell.

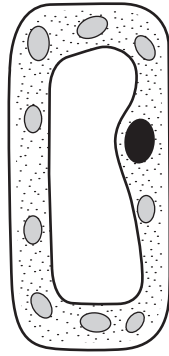

Which structure is **not** shown?

- A cell membrane
  - B cell wall
  - C chloroplast
  - D vacuole
- 2 The diagram shows some red blood cells.

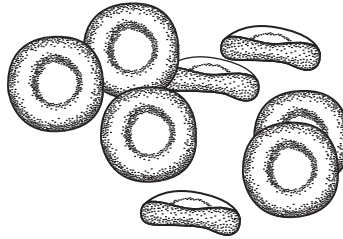

What is the function of these cells?

- A antibody formation
- B carry oxygen
- C make glucose
- D phagocytosis

- 3 A plant has leaves which are green and white. One of the leaves is partly covered by a piece of black card. The plant is left under a lamp for two days.

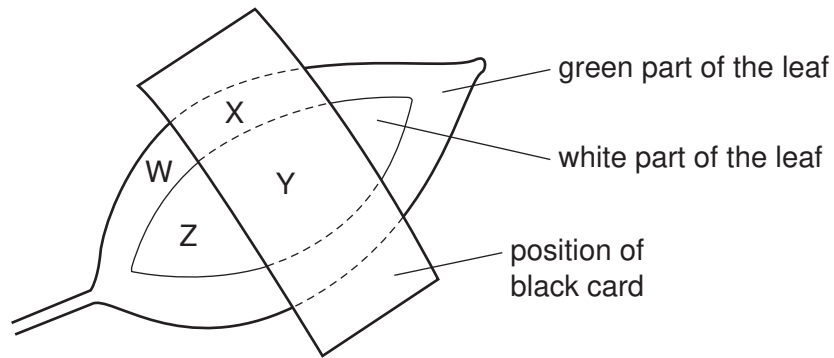

The leaf is then removed from the plant and tested for starch (the carbohydrate made during photosynthesis).

Which row is correct?

	W	X	Y	Z
<b>A</b>	✓	✓	x	x
<b>B</b>	✓	x	x	x
<b>C</b>	x	✓	✓	x
<b>D</b>	x	x	✓	✓

key

✓ = starch present

x = starch absent

- 4 Which word equation represents aerobic respiration?

- A** carbon dioxide + oxygen → glucose + water  
**B** carbon dioxide + water → glucose + oxygen  
**C** glucose + oxygen → carbon dioxide + water  
**D** glucose + oxygen → lactic acid

- 5 The diagram shows the heart, liver and kidneys with connecting blood vessels.

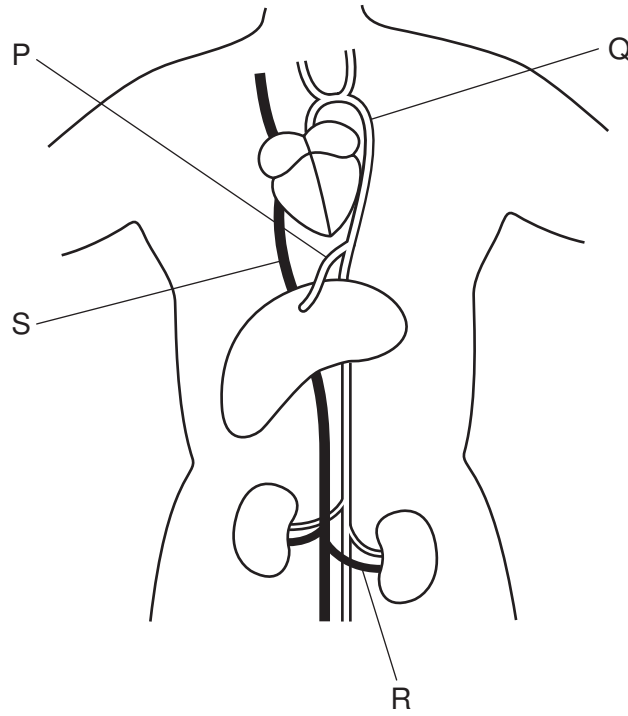

What are the labelled blood vessels?

	aorta	hepatic artery	vena cava	renal vein
<b>A</b>	Q	P	S	R
<b>B</b>	Q	R	S	P
<b>C</b>	S	P	Q	R
<b>D</b>	S	R	Q	P

- 6 The diagram shows a tooth with a cavity caused by decay.

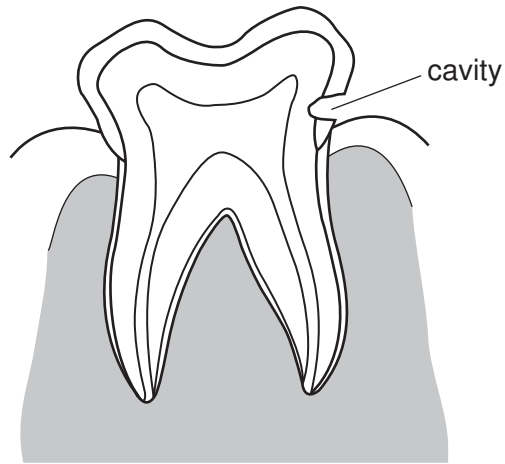

Which part of the tooth has been exposed by the decay?

- A enamel
  - B dentine
  - C pulp
  - D root
- 7 The diagram shows part of the digestive system.

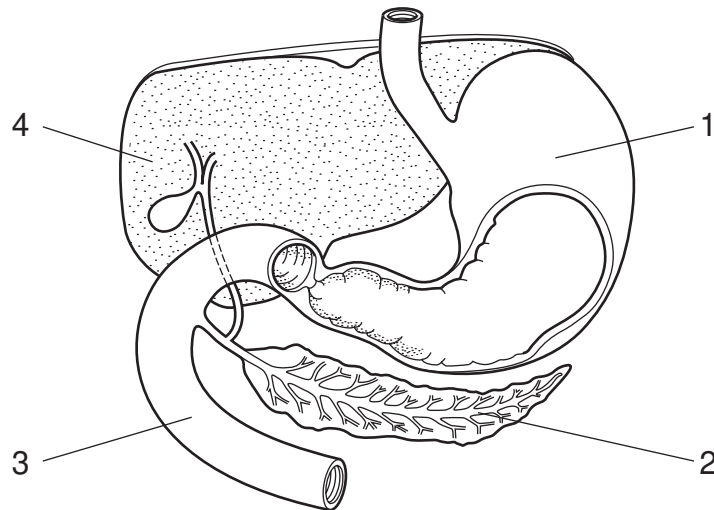

Which labels identify the liver, pancreas and stomach?

	liver	pancreas	stomach
<b>A</b>	2	1	3
<b>B</b>	2	3	1
<b>C</b>	4	2	3
<b>D</b>	4	2	1

8 A person touches a hot object which triggers a reflex action.

In which order does the signal travel in the reflex arc?

- A relay neurone → spinal cord → sensory neurone
- B sensory neurone → spinal cord → motor neurone
- C spinal cord → sensory neurone → stimulus
- D stimulus → motor neurone → spinal cord

9 Which organ in the body makes urea and how is urea removed from that organ?

	where made	how removed
<b>A</b>	kidneys	in urine
<b>B</b>	liver	in blood
<b>C</b>	liver	in bile
<b>D</b>	pancreas	in pancreatic juice

10 Which structure produces seminal fluid?

- A prostate gland
- B sperm duct
- C testis
- D urethra

11 In plants, the allele for red flowers is dominant to the allele for white flowers.

A heterozygous red-flowered plant is crossed with a white-flowered plant.

What percentage of the offspring will have red flowers?

- A 25%
- B 50%
- C 75%
- D 100%

12 The diagram shows a food chain.

Which organisms pass the greatest amount of energy along the food chain?



13 The diagram shows part of the carbon cycle.

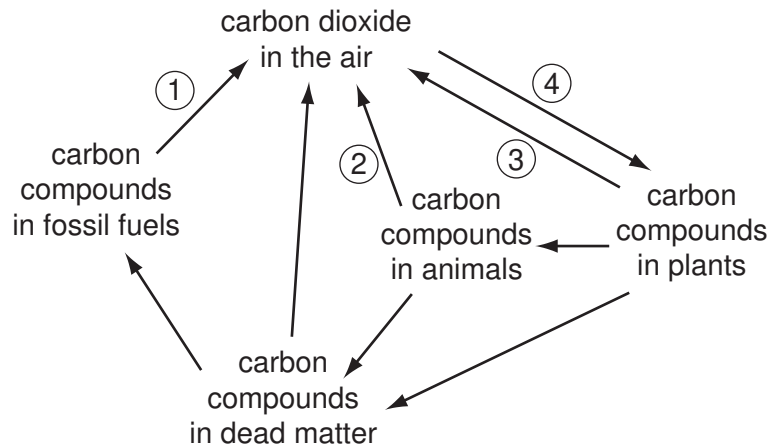

Where are photosynthesis and respiration happening?

	photosynthesis	respiration
<b>A</b>	3	2
<b>B</b>	3	4
<b>C</b>	4	1
<b>D</b>	4	3

14 The colours in an ink can be separated by chromatography.

Which diagram shows the correct way to set up the apparatus?

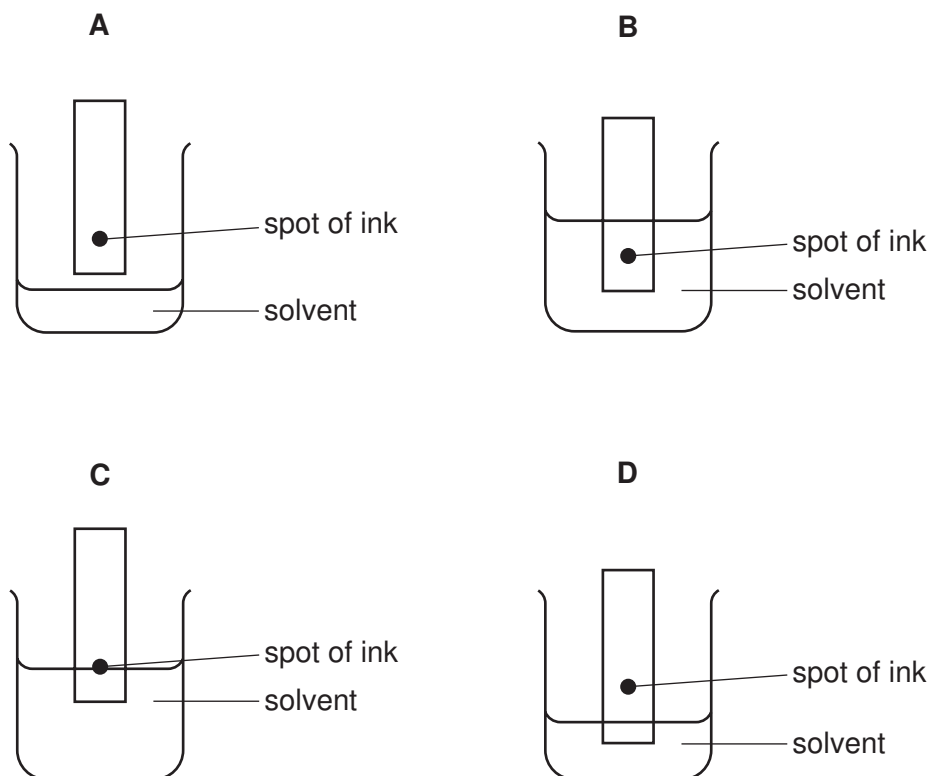

15 The symbol for an atom of neon is  ${}_{10}^{20}\text{Ne}$ .

Which statement about the atom is correct?

- A It contains half as many neutrons as protons.
- B It contains twice as many neutrons as protons.
- C The number of neutrons equals the number of protons.
- D The total number of neutrons and protons is thirty.

16 Which formula contains the most elements?

- A NaOH                      B  $\text{Rb}_2\text{S}$                       C  $\text{SiCl}_4$                       D  $\text{SnO}_2$

17 The apparatus shown is used to investigate the speed of reaction between hydrochloric acid and calcium carbonate.

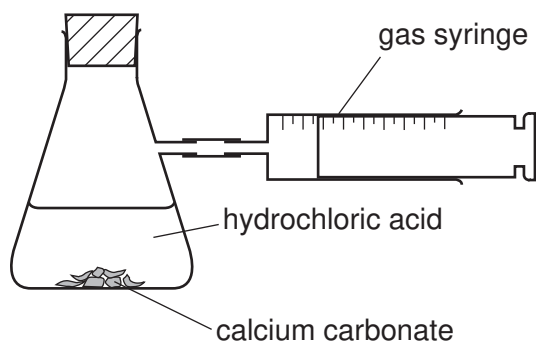

The time to collect  $50\text{ cm}^3$  of gas is measured.

Using concentrated acid and lumps of calcium carbonate, the time is 150 s.

In a second experiment, the time is 90 s.

Which change was made in the second experiment?

- A larger lumps of calcium carbonate
- B less concentrated acid
- C lower temperature
- D powdered calcium carbonate

18 Which substance is reduced during the following reaction?

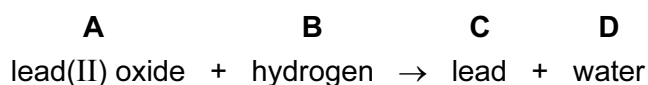



19 A coloured solution of compound X gives a white precipitate with acidified silver nitrate.

What is X?

- A calcium chloride
- B calcium sulfate
- C copper(II) chloride
- D copper(II) sulfate

20 Which box contains a solution of a metal oxide?

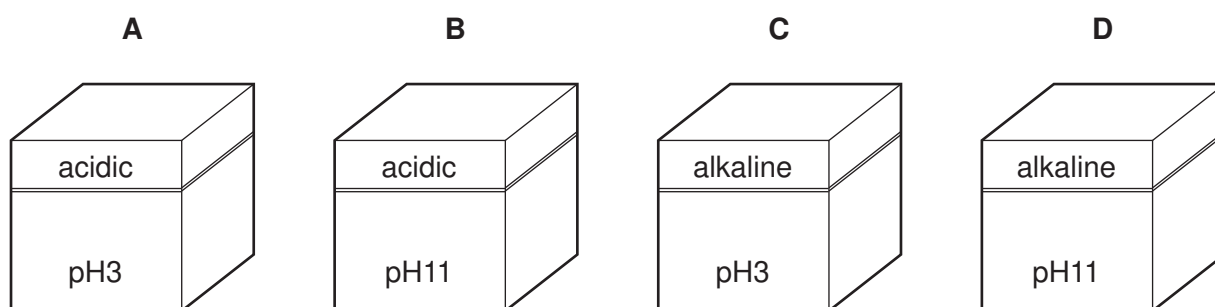

21 The table shows physical properties of some substances.

Which substance is a metal?

	malleability	density	electrical conductivity
<b>A</b>	brittle	high density	high
<b>B</b>	brittle	low density	low
<b>C</b>	malleable	high density	high
<b>D</b>	malleable	low density	low

22 The diagram shows part of the Periodic Table.

Which letter shows the position of a metal with a low melting point?

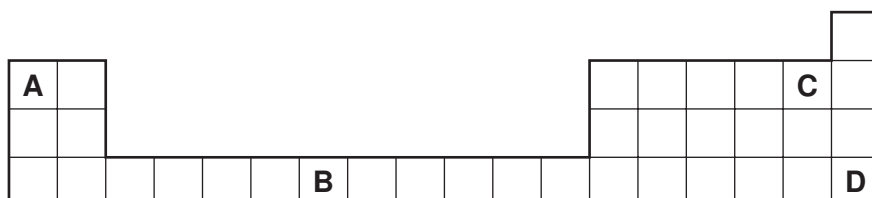

23 Copper(II) oxide is mixed with a solid Q.

On heating the mixture, a reaction occurs and the limewater turns milky.

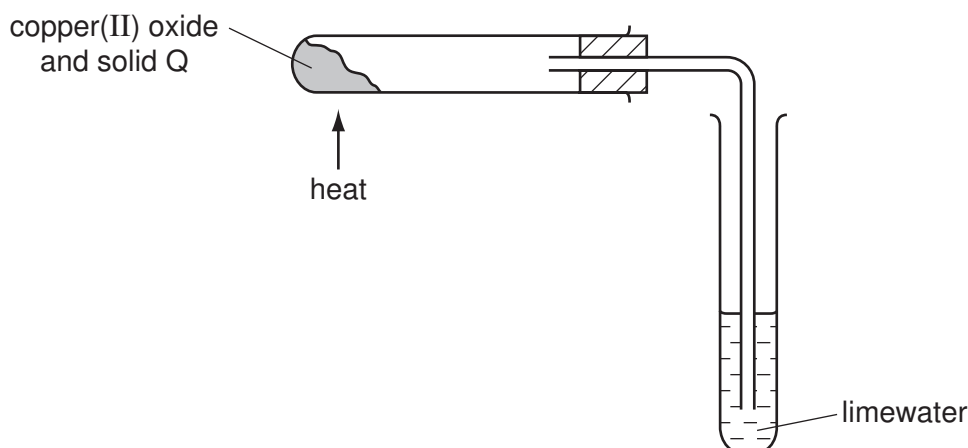

What is solid Q?

- A carbon
- B iron
- C sulfur
- D zinc

24 The diagram shows gas P being passed through liquid X and then over iron filings.

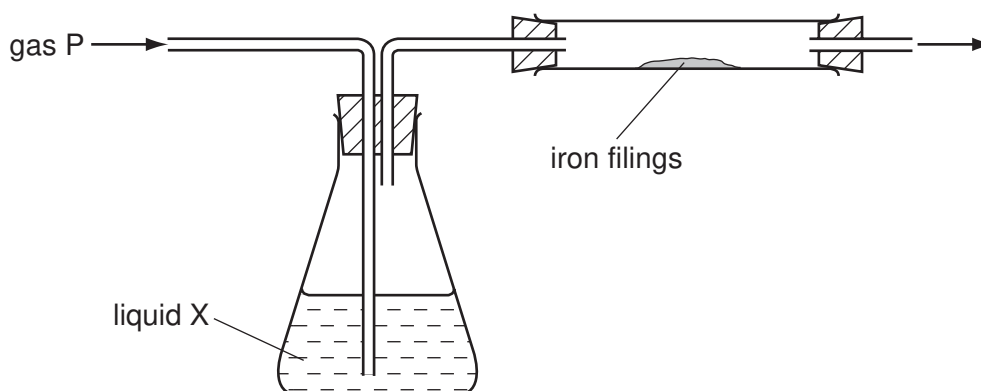

Which gas and liquid cause the iron to rust?

	gas P	liquid X
A	nitrogen	concentrated sulfuric acid (a drying agent)
B	nitrogen	water
C	oxygen	concentrated sulfuric acid (a drying agent)
D	oxygen	water

25 Fertilisers are used to supply the essential elements needed for plant growth.

Which compound supplies two of these essential elements?

- A  $\text{Ca}(\text{H}_2\text{PO}_4)_2$
- B  $\text{Ca}(\text{NO}_3)_2$
- C  $\text{KNO}_3$
- D  $(\text{NH}_4)_2\text{SO}_4$

26 The burning of a fuel is investigated using the apparatus shown.

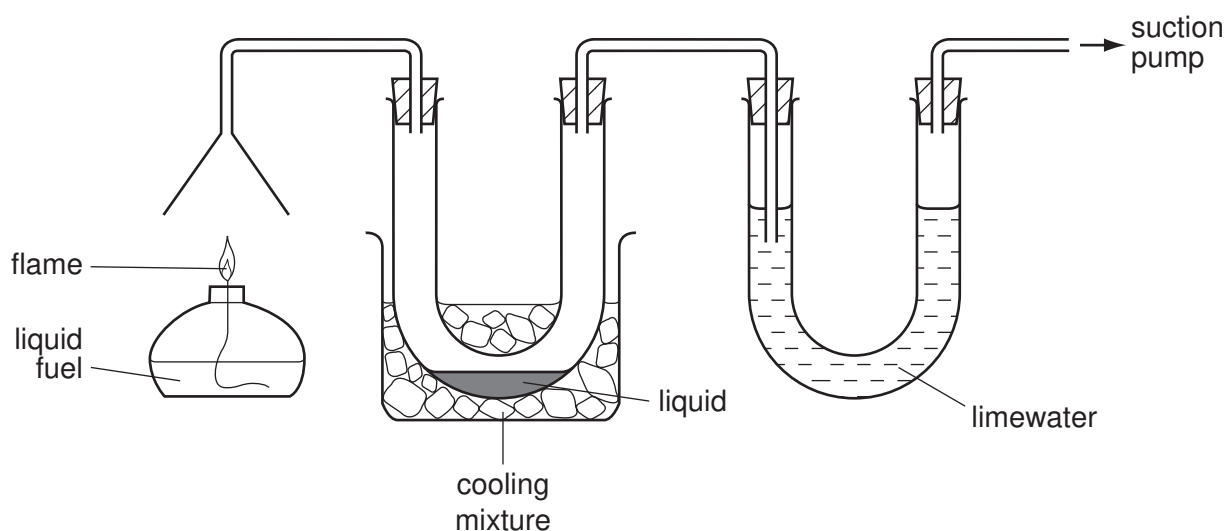

Which substances is the apparatus testing for?

- A carbon monoxide and carbon dioxide
- B carbon monoxide and water
- C carbon dioxide and water
- D carbon dioxide and sulfur dioxide

27 This description of a plastic is incomplete.

To make a plastic, .....1..... of a .....2..... combine to form a long chain .....3..... .

Which words correctly complete the gaps?

	1	2	3
A	atoms	monomer	polymer
B	atoms	polymer	monomer
C	molecules	monomer	polymer
D	molecules	polymer	monomer

28 The graph shows how the distance of an object changes with time.

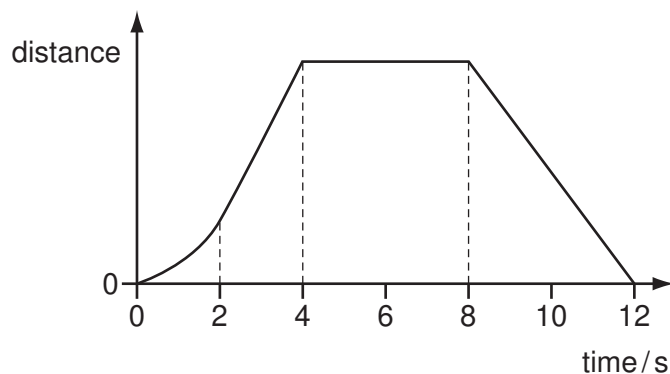

Between which two times is the object moving with a changing speed?

- A between 0 s and 2 s
- B between 2 s and 4 s
- C between 4 s and 8 s
- D between 8 s and 12 s

29 The diagrams show a glass tank with inside measurements of 5 cm × 6 cm × 4 cm.

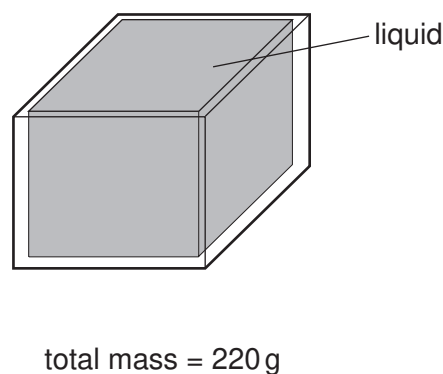
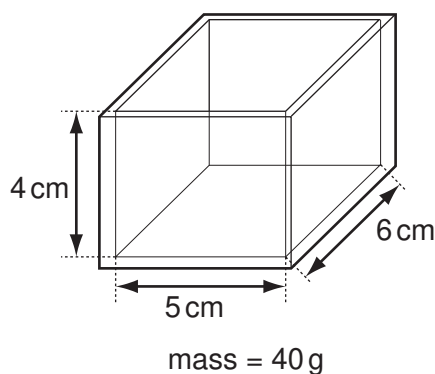

The tank has a mass of 40 g when empty. When the tank is filled with a liquid, the tank and liquid have a total mass of 220 g.

What is the density of the liquid?

- A  $\frac{220}{(5 \times 6 \times 4)} \text{ g/cm}^3$
- B  $\frac{(220 - 40)}{(5 \times 6 \times 4)} \text{ g/cm}^3$
- C  $\frac{(5 \times 6 \times 4)}{220} \text{ g/cm}^3$
- D  $\frac{(5 \times 6 \times 4)}{(220 - 40)} \text{ g/cm}^3$

30 Which energy resource did **not** receive its energy from the Sun?

- A geothermal
- B hydroelectric
- C oil
- D waves

31 A glass bottle containing air is sealed with a screw cap and then cooled in cold water.

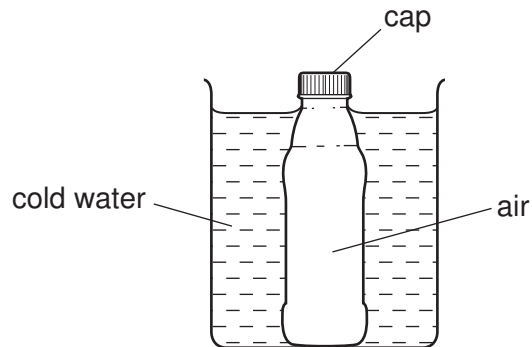

The contraction of the glass bottle can be ignored.

What remains the same during the cooling?

- A the air pressure inside the bottle
- B the energy of the air molecules in the bottle
- C the force on the cap made by the air molecules in the bottle
- D the volume of air inside the bottle

32 What happens to the temperature of a substance as it is melting and as it is boiling?

	melting	boiling
<b>A</b>	decreases	increases
<b>B</b>	decreases	no change
<b>C</b>	increases	increases
<b>D</b>	no change	no change

- 33 A hot metal ball is placed in a small hollow in a piece of wood. Two thermometers are placed at equal distances from the ball, one at position P and one at position Q.

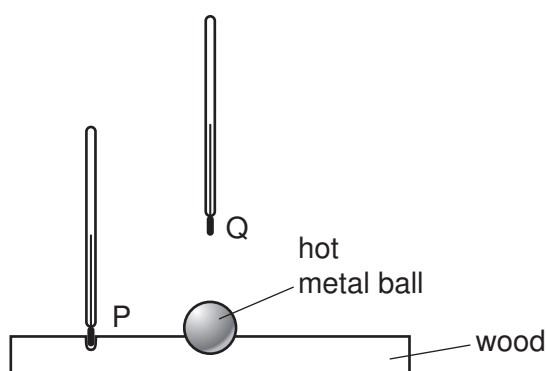

Which thermometer gives the highest reading and why?

	highest reading	reason
<b>A</b>	thermometer at P	the air conducts heat sideways, not upwards
<b>B</b>	thermometer at P	the wood conducts the heat sideways, not upwards
<b>C</b>	thermometer at Q	convection carries the heat upwards, not sideways
<b>D</b>	thermometer at Q	infra-red rays carry the heat upwards more than sideways

- 34 A converging lens in a camera is used to make an image on a film. The image is smaller than the object.

At which point could the object be placed so that it makes this image?

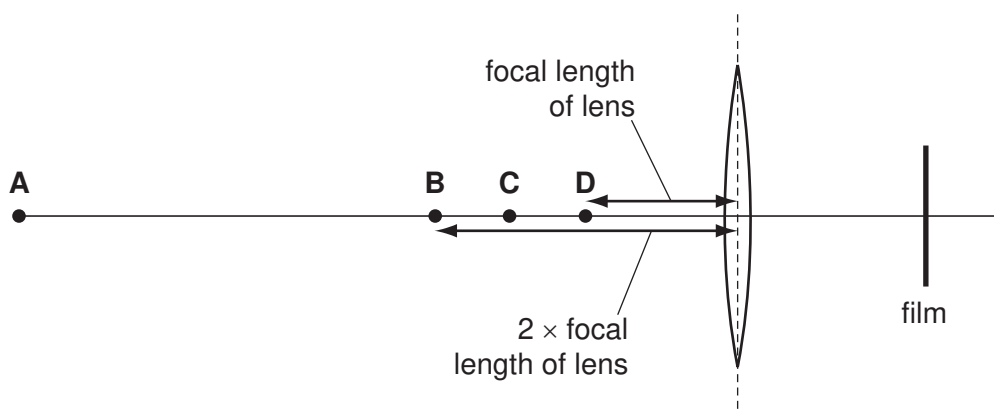

- 35 The Sun emits infra-red radiation, ultraviolet radiation and visible light.

Which statement about the time it takes these radiations to reach Earth's atmosphere is correct?

- A** Infra-red radiation arrives first.
- B** Ultraviolet radiation arrives first.
- C** Visible light arrives first.
- D** They all arrive at the same time.

- 36 Astronaut 1 uses a hammer to mend a satellite in space. Astronaut 2 is nearby. They are in space.

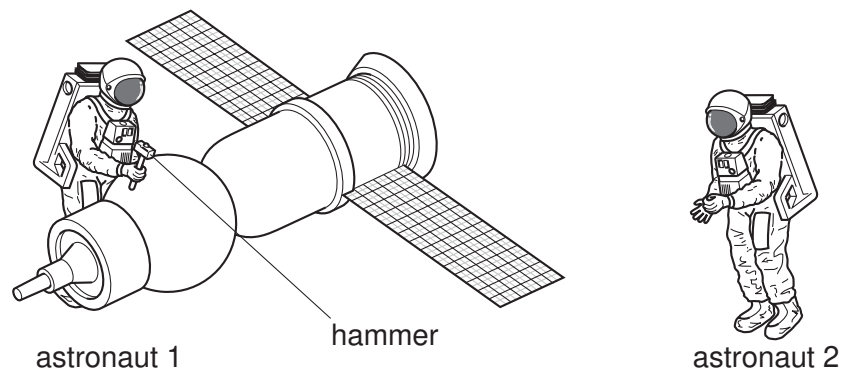

Compared with the sound heard if they were working on Earth, what does astronaut 2 hear?

- A a louder sound
  - B a quieter sound
  - C a sound of the same loudness
  - D no sound at all
- 37 The instructions for a household lamp state that the plug should be fitted with a 3 A fuse.

What could happen if, by mistake, a 13 A fuse is fitted?

- A The fuse might melt too easily.
- B The lamp might explode if a fault develops.
- C The wires connecting the lamp to the plug might overheat if a fault developed.
- D Too much voltage might be supplied to the lamp.

- 38 An electric current flows along a wire. A magnetic field is at right angles to it (into the page) causes a force on the wire to the right.

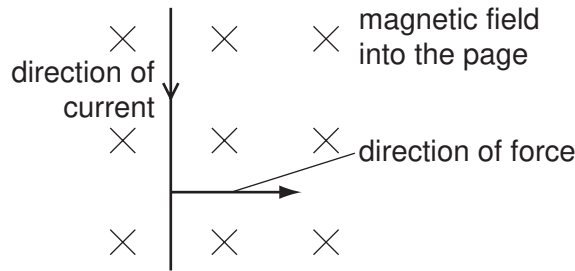

In which direction is the force when the current direction is reversed?

- A to the right
  - B to the left
  - C upwards
  - D downwards
- 39 Which row describes the nature of alpha and beta radiation?

	alpha	beta
A	electron	electromagnetic wave
B	electron	helium nucleus
C	helium nucleus	electromagnetic wave
D	helium nucleus	electron

- 40 The diagrams represent the nuclei of four different atoms V, W, X and Y.

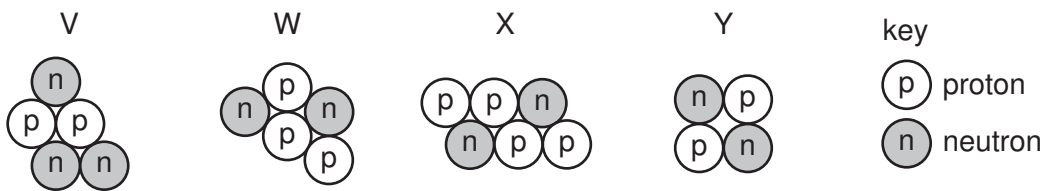

Which two diagrams represent isotopes of the same element?

- A V and W
- B W and X
- C X and Y
- D Y and V









## DATA SHEET

### The Periodic Table of the Elements

Group																					
I	II											III	IV	V	VI	VII	0				
										1 <b>H</b> Hydrogen 1											4 <b>He</b> Helium 2
7 <b>Li</b> Lithium 3	9 <b>Be</b> Beryllium 4											11 <b>B</b> Boron 5	12 <b>C</b> Carbon 6	14 <b>N</b> Nitrogen 7	16 <b>O</b> Oxygen 8	19 <b>F</b> Fluorine 9	20 <b>Ne</b> Neon 10				
23 <b>Na</b> Sodium 11	24 <b>Mg</b> Magnesium 12											27 <b>Al</b> Aluminium 13	28 <b>Si</b> Silicon 14	31 <b>P</b> Phosphorus 15	32 <b>S</b> Sulfur 16	35.5 <b>Cl</b> Chlorine 17	40 <b>Ar</b> Argon 18				
39 <b>K</b> Potassium 19	40 <b>Ca</b> Calcium 20	45 <b>Sc</b> Scandium 21	48 <b>Ti</b> Titanium 22	51 <b>V</b> Vanadium 23	52 <b>Cr</b> Chromium 24	55 <b>Mn</b> Manganese 25	56 <b>Fe</b> Iron 26	59 <b>Co</b> Cobalt 27	59 <b>Ni</b> Nickel 28	64 <b>Cu</b> Copper 29	65 <b>Zn</b> Zinc 30	70 <b>Ga</b> Gallium 31	73 <b>Ge</b> Germanium 32	75 <b>As</b> Arsenic 33	79 <b>Se</b> Selenium 34	80 <b>Br</b> Bromine 35	84 <b>Kr</b> Krypton 36				
85 <b>Rb</b> Rubidium 37	88 <b>Sr</b> Strontium 38	89 <b>Y</b> Yttrium 39	91 <b>Zr</b> Zirconium 40	93 <b>Nb</b> Niobium 41	96 <b>Mo</b> Molybdenum 42	96 <b>Tc</b> Technetium 43	101 <b>Ru</b> Ruthenium 44	103 <b>Rh</b> Rhodium 45	106 <b>Pd</b> Palladium 46	108 <b>Ag</b> Silver 47	112 <b>Cd</b> Cadmium 48	115 <b>In</b> Indium 49	119 <b>Sn</b> Tin 50	122 <b>Sb</b> Antimony 51	128 <b>Te</b> Tellurium 52	127 <b>I</b> Iodine 53	131 <b>Xe</b> Xenon 54				
133 <b>Cs</b> Caesium 55	137 <b>Ba</b> Barium 56	139 <b>La</b> Lanthanum 57 *	178 <b>Hf</b> Hafnium 72	181 <b>Ta</b> Tantalum 73	184 <b>W</b> Tungsten 74	186 <b>Re</b> Rhenium 75	190 <b>Os</b> Osmium 76	192 <b>Ir</b> Iridium 77	195 <b>Pt</b> Platinum 78	197 <b>Au</b> Gold 79	201 <b>Hg</b> Mercury 80	204 <b>Tl</b> Thallium 81	207 <b>Pb</b> Lead 82	209 <b>Bi</b> Bismuth 83	210 <b>Po</b> Polonium 84	210 <b>At</b> Astatine 85	210 <b>Rn</b> Radon 86				
87 <b>Fr</b> Francium	226 <b>Ra</b> Radium	227 <b>Ac</b> Actinium †																			

\*58-71 Lanthanoid series

†90-103 Actinoid series

Key

a	a = relative atomic mass
<b>X</b>	X = atomic symbol
b	b = proton (atomic) number

140 <b>Ce</b> Cerium 58	141 <b>Pr</b> Praseodymium 59	144 <b>Nd</b> Neodymium 60	147 <b>Pm</b> Promethium 61	150 <b>Sm</b> Samarium 62	152 <b>Eu</b> Europium 63	157 <b>Gd</b> Gadolinium 64	159 <b>Tb</b> Terbium 65	162 <b>Dy</b> Dysprosium 66	165 <b>Ho</b> Holmium 67	167 <b>Er</b> Erbium 68	169 <b>Tm</b> Thulium 69	173 <b>Yb</b> Ytterbium 70	175 <b>Lu</b> Lutetium 71
232 <b>Th</b> Thorium 90	234 <b>Pa</b> Protactinium 91	238 <b>U</b> Uranium 92	237 <b>Np</b> Neptunium 93	244 <b>Pu</b> Plutonium 94	247 <b>Am</b> Americium 95	251 <b>Cm</b> Curium 96	257 <b>Bk</b> Berkelium 97	261 <b>Cf</b> Californium 98	267 <b>Es</b> Einsteinium 99	271 <b>Fm</b> Fermium 100	277 <b>Md</b> Mendelevium 101	285 <b>No</b> Nobelium 102	289 <b>Lr</b> Lawrencium 103

The volume of one mole of any gas is 24 dm<sup>3</sup> at room temperature and pressure (r.t.p.).

Permission to reproduce items where third-party owned material protected by copyright is included has been sought and cleared where possible. Every reasonable effort has been made by the publisher (UCLES) to trace copyright holders, but if any items requiring clearance have unwittingly been included, the publisher will be pleased to make amends at the earliest possible opportunity.

University of Cambridge International Examinations is part of the Cambridge Assessment Group. Cambridge Assessment is the brand name of University of