

Centre Number

Candidate Number

Name

www.PapaCambridge.com

CAMBRIDGE INTERNATIONAL EXAMINATIONS
International General Certificate of Secondary Education

CO-ORDINATED SCIENCES

0654/01

Paper 1 Multiple Choice

May/June 2003

45 minutes

Additional Materials: Multiple Choice Answer Sheet
Soft clean eraser
Soft pencil (type B or HB is recommended)

READ THESE INSTRUCTIONS FIRST

Write in soft pencil.

Do not use staples, paper clips, highlighters, glue or correction fluid.

Write your name, Centre number and candidate number on the answer sheet in the spaces provided unless this has been done for you.

There are **forty** questions on this paper. Answer **all** questions. For each question there are four possible answers **A, B, C, and D**.

Choose the **one** you consider correct and record your choice in **soft pencil** on the separate answer sheet.

Read the instructions on the Answer Sheet very carefully.

Each correct answer will score one mark. A mark will not be deducted for a wrong answer.

Any rough working should be done in this booklet.

A copy of the Periodic Table is printed on page 20.

This document consists of **17** printed pages and **3** blank pages.

UNIVERSITY of CAMBRIDGE

1 The diagram shows a flower.

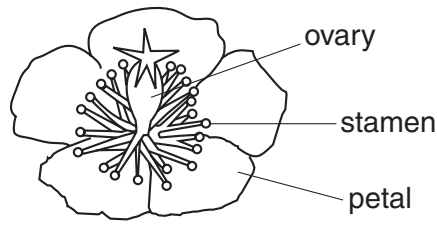

Use the key to identify the flower.

- 1 Petals four go to 2
- Petals five go to 3

- 2 Ovary above the petals flower **A**
- Ovary below the petals flower **B**

- 3 Stamens less than five flower **C**
- Stamens more than five flower **D**

2 The diagram shows a partially permeable membrane through which molecules pass only by osmosis.

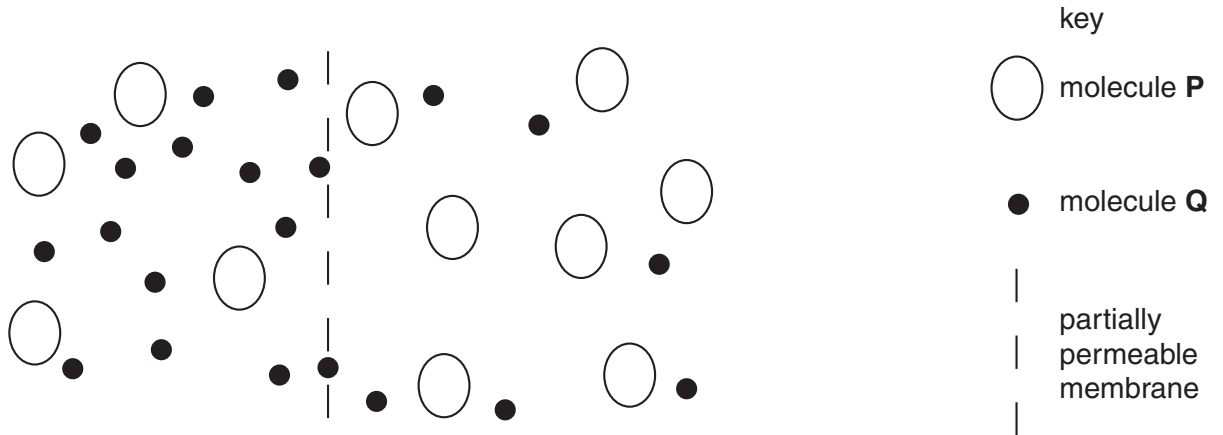

What is molecule **Q**?

- A** amino acid
- B** starch
- C** sugar
- D** water

3 What is the main support for the stems of woody plants?

- A cartilage
- B lignin
- C phloem
- D turgidity

4 The diagram shows a section through a green leaf.

Where are carbohydrates made?

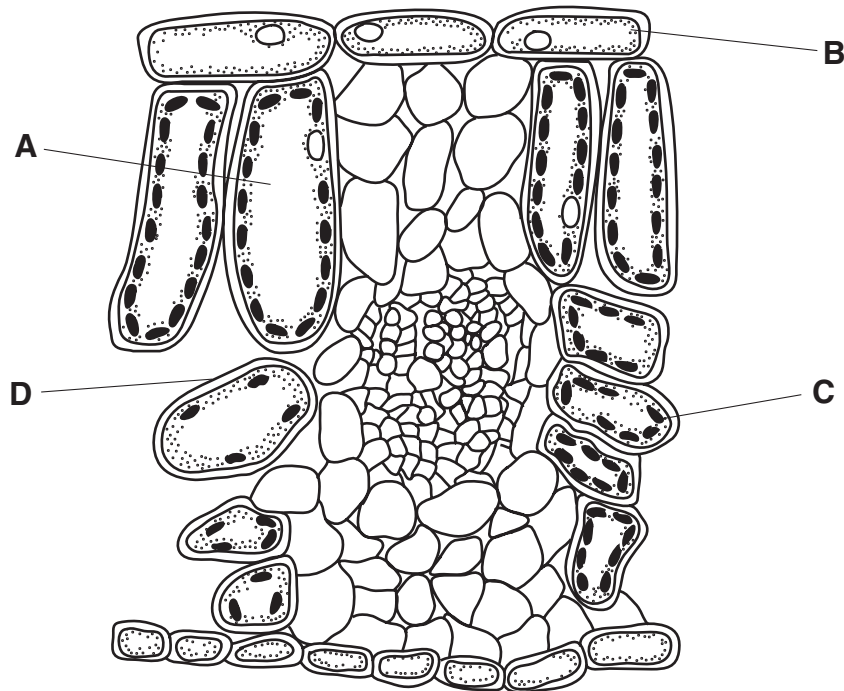

5 Which are products of respiration?

- A carbon dioxide and nitrogen
- B carbon dioxide and water
- C nitrogen and water
- D oxygen and carbon dioxide

- 6 From which chamber of the human heart is blood pumped most strongly?

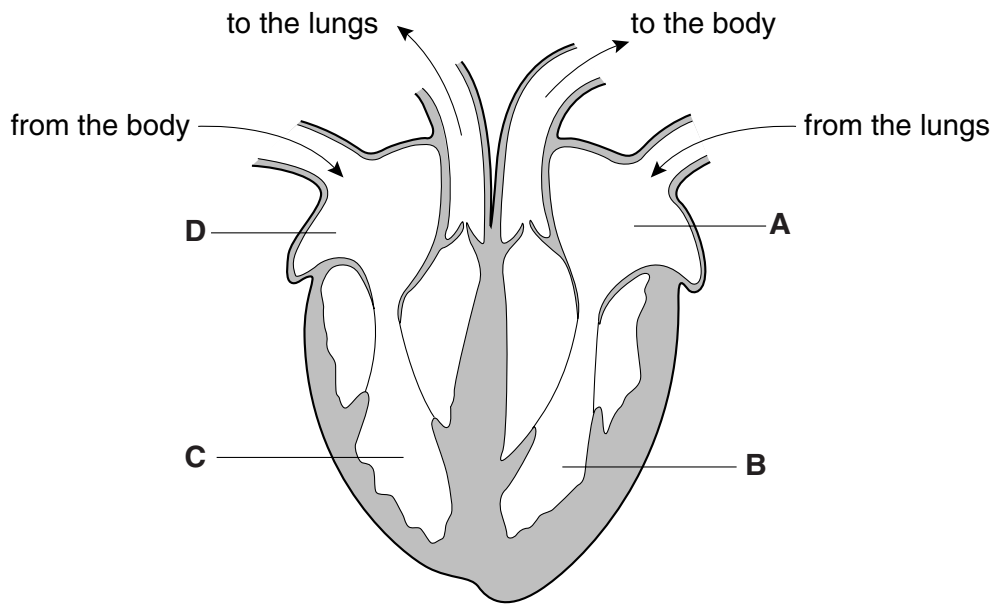

Mackean (adapted)

- 7 Which of the following is part of a haemoglobin molecule?

- A calcium
- B iron
- C vitamin C
- D vitamin D

- 8 The table shows the amount of protein and fat in 100 g samples of some foods.

foods	protein /g	fat /g
meat	18.0	17.0
bread	9.0	1.5
fish	18.0	0.5
eggs	13.0	11.0
potato chips	4.0	9.0

Which foods are the best value for body-building?

- A bread and meat
- B bread and potato chips
- C meat and eggs
- D meat and fish

9 What is **always** released when respiration takes place?

- A carbon dioxide
- B energy
- C lactic acid
- D water

10 The diagram shows a human kidney and its blood supply.

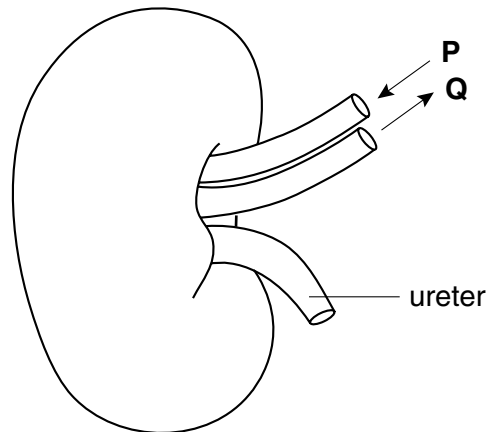

Compared with the blood in vessel **P**, the blood in **Q** has

- A less urea and less oxygen.
 - B less urea and more oxygen.
 - C more urea and less oxygen.
 - D more urea and more oxygen.
- 11 A student placed four sets of seeds in different conditions.

Which set of conditions must be kept constant to show the effect of temperature on germination?

- A temperature and water only
- B temperature only
- C temperature, water and oxygen
- D water, oxygen and light intensity

12 The diagram shows the human male reproductive system.

In which region are sperms produced?

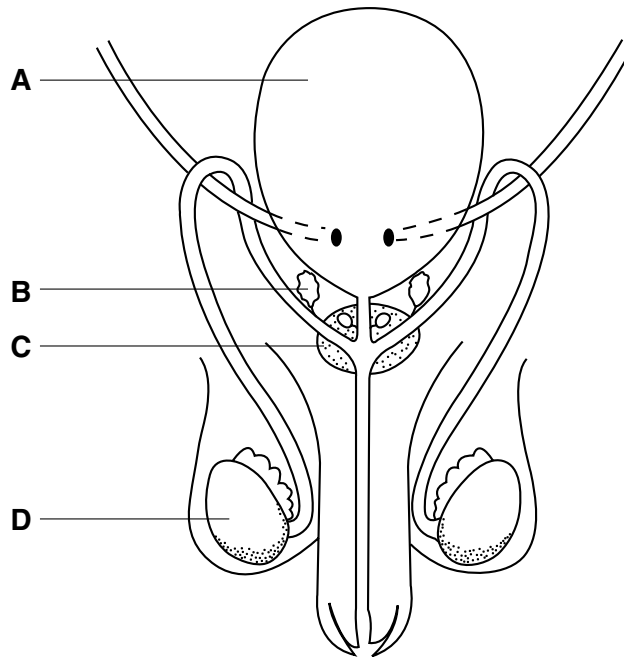

13 A heterozygous tall plant was crossed with a pure-breeding short plant of the same species. The resulting seeds were collected and grown to produce the next generation.

What were the approximate percentages of tall and short offspring?

	percentage of tall offspring	percentage of short offspring
A	25	75
B	50	50
C	75	25
D	100	0

14 The diagram shows a food web of four organisms. The arrows in the diagram show the flow of energy in the food web.

Which organism is a producer?

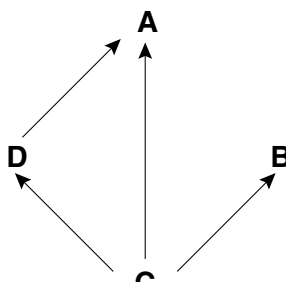

15 Hydrogen is burnt in air, as shown.

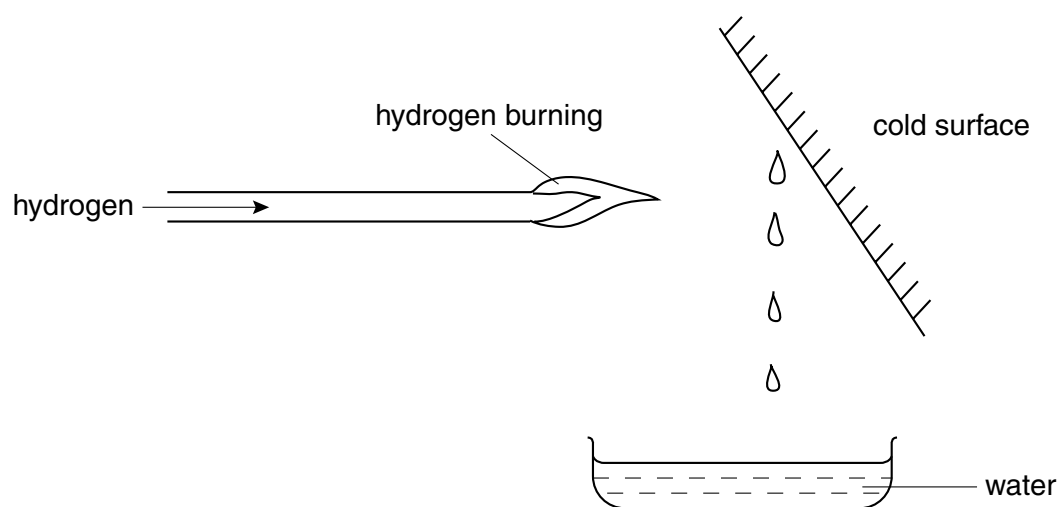

What happens?

- A Atoms of water are formed.
 - B The element water is formed.
 - C The compound water is formed.
 - D The mixture water is formed.
- 16 Element X can form 4 covalent bonds. Element Y can form 2 covalent bonds.

What is the simplest formula of the compound formed by X and Y?

- A XY_2
- B X_2Y
- C X_2Y_4
- D X_4Y_2

17 Samples of four different materials are tested in the experiments shown.

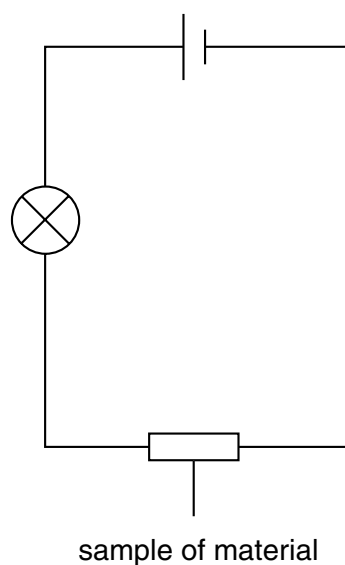

experiment 1

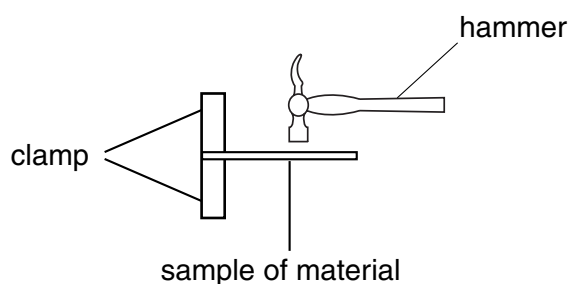

experiment 2

The results are given in the table.

Which material is a metal?

material	experiment 1	experiment 2
A	lamp does not light	bends
B	lamp does not light	breaks
C	lamp lights	bends
D	lamp lights	breaks

18 Which words correctly complete the gaps below?

Molecules of1..... join together to form2..... that is thermoplastic and3..... on heating.

	gap 1	gap 2	gap 3
A	a monomer	a polymer	hardens
B	a monomer	a polymer	softens
C	a polymer	a monomer	hardens
D	a polymer	a monomer	softens

- 19 Visking tubing is partially permeable. A length of this tubing is filled with aqueous glucose, placed in pure water and left for an hour.

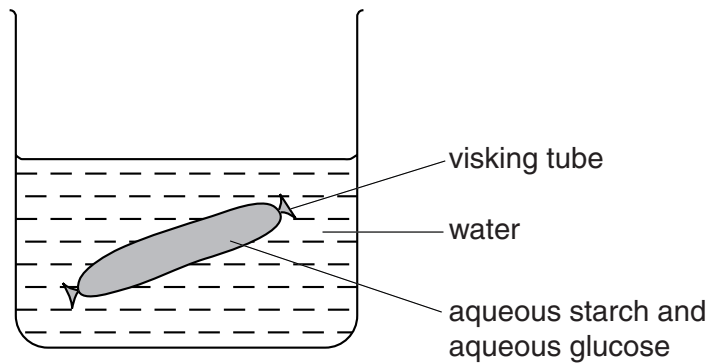

Iodine tests and Benedict's tests are then carried out. The results are shown below.

liquid tested	iodine test	Benedict's test
inside visking tubing	blue/black	orange/red suspension
outside visking tubing	no change	orange/red suspension

Which substances can pass through the tubing?

- A both glucose and starch
 - B only glucose
 - C only starch
 - D neither glucose nor starch
- 20 A material is tested as shown.

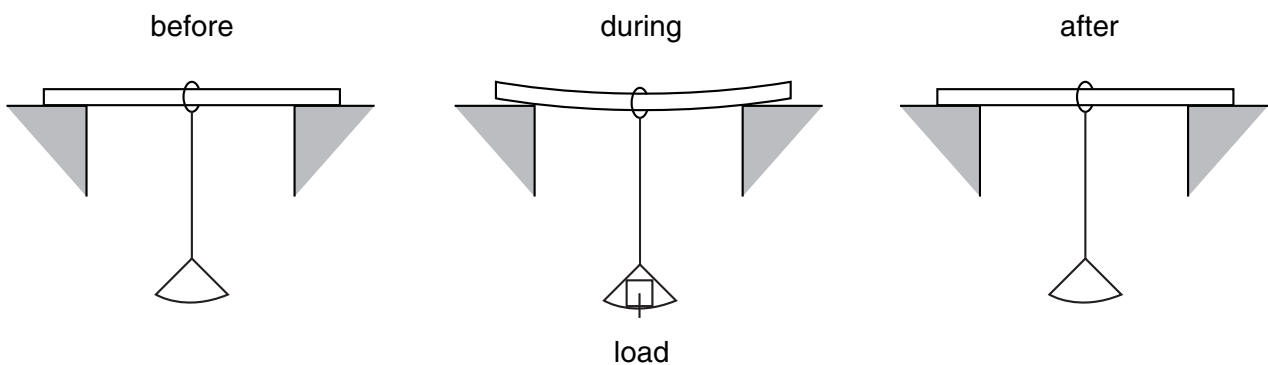

Which property of the material is being tested?

- A elasticity
- B electrical conductivity
- C hardness
- D porosity

21 The names and formulae of four minerals are shown.

Which mineral does **not** contain a metallic element?

bauxite	Al_2O_3
galena	PbS
horn silver	AgCl
quartz	SiO_2

- A bauxite
- B galena
- C horn silver
- D quartz

22 The catalytic converter in the exhaust of a car brings about the following reaction.

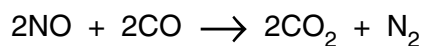

Which changes take place?

	oxidation	reduction
A	✓	✓
B	✓	✗
C	✗	✓
D	✗	✗

23 Tests on some 10 cm^3 samples of tap water give the following results.

test	result
add 2 cm^3 of soap solution and shake	no lather
boil the tap water, add 2 cm^3 of soap solution and shake	lather
add acidified aqueous barium nitrate	white precipitate

What do the results show about the tap water?

- A It is hard and contains chloride ions.
- B It is hard and contains sulphate ions.
- C It is soft and contains chloride ions.
- D It is soft and contains sulphate ions.

- 24 Which of the following is formed as a result of the weathering of rocks?
- A limestone
B methane
C soil
D water
- 25 Which metal is used with aqueous sodium hydroxide to test for nitrate ions in solution?
- A aluminium
B copper
C magnesium
D tin
- 26 Ethanol is burnt in a spirit burner as shown.

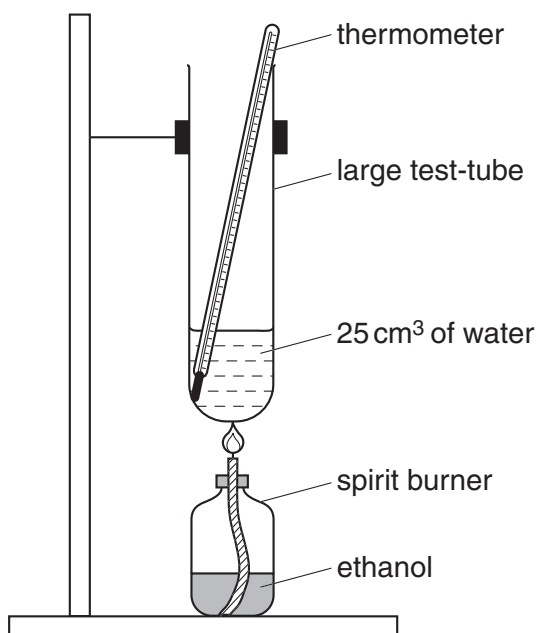

The mass of the burner and its contents is measured before and after the experiment. The thermometer is read before and after the experiment.

What are the expected results?

	mass of burner and contents	thermometer reading
A	decreases	increases
B	decreases	stays the same
C	increases	increases
D	increases	stays the same

- 30 A spring is suspended from a stand. Loads are added and the extensions are measured.

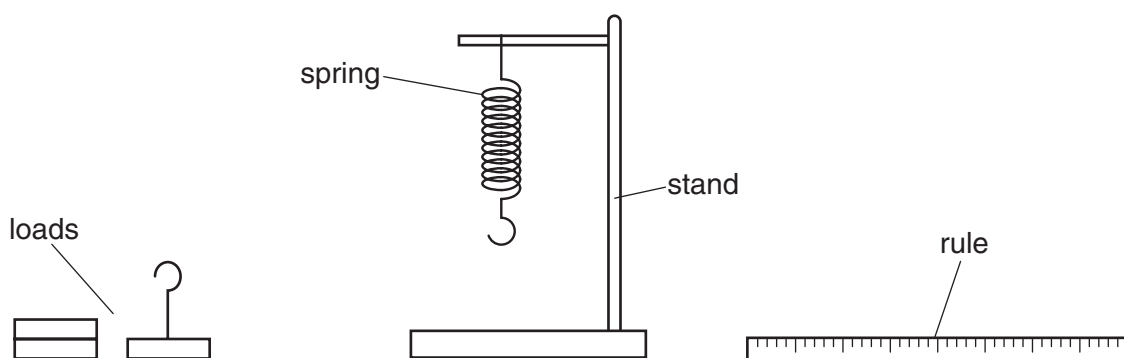

Which graph shows the result of plotting extension against load?

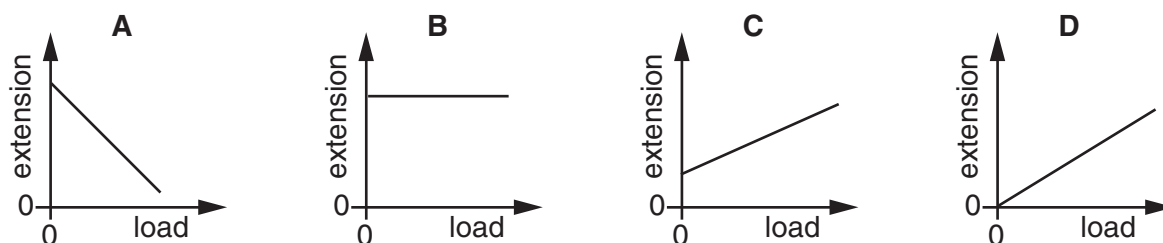

- 31 When water evaporates, some molecules escape.

Which molecules escape?

- A the molecules at the bottom of the liquid with less energy than others
 - B the molecules at the bottom of the liquid with more energy than others
 - C the molecules at the surface with less energy than others
 - D the molecules at the surface with more energy than others
- 32 A person holds a glass beaker in one hand and fills it quickly with hot water. It takes several seconds before his hand starts to feel the heat.

Why is there this delay?

- A Glass is a poor conductor of heat.
- B Glass is a good conductor of heat.
- C Water is a poor conductor of heat.
- D Water is a good conductor of heat.

33 What causes refraction when light travels from air into glass?

- A The amplitude of the light waves changes.
- B The colour of the light changes.
- C The frequency of the light waves changes.
- D The speed of the light changes.

34 A woman tunes her radio to a station broadcasting on 200 m.

What does the 200 m tell her about the radio wave?

- A its amplitude
- B its frequency
- C its speed
- D its wavelength

35 Which diagram correctly shows rays passing through a camera lens?

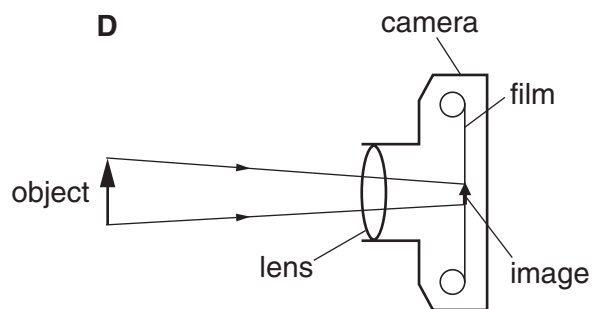
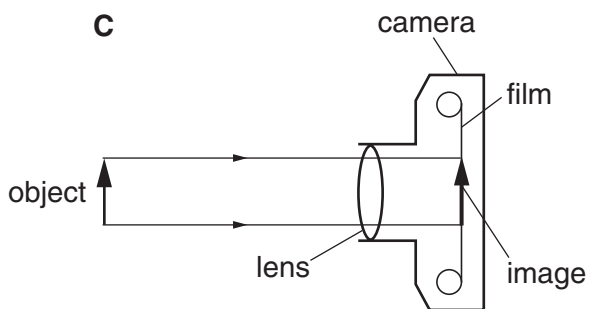
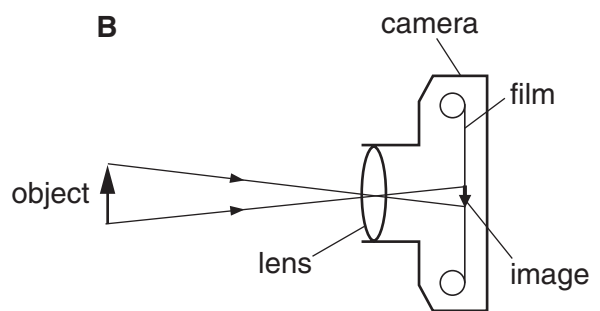
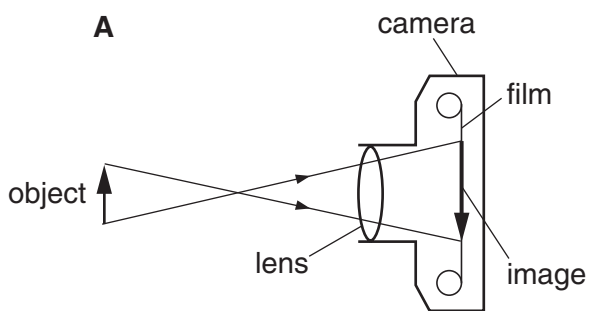

- 36 A metal rod XY is placed near a magnet. End X is attracted when it is placed near the north pole of the magnet, and also when it is placed near to the south pole.

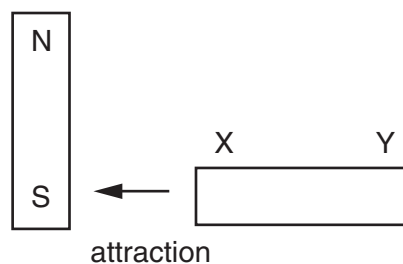
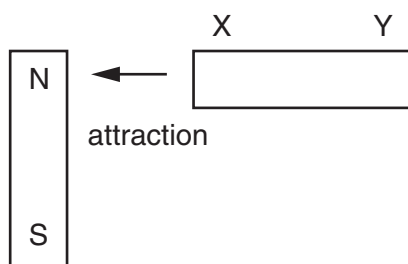

How does end Y behave when it is placed, in turn, near to the two poles of the magnet?

	Y near north pole	Y near south pole
A	attraction	attraction
B	attraction	repulsion
C	repulsion	attraction
D	repulsion	repulsion

- 37 When the potential difference (p.d.) across a piece of resistance wire is changed, the current through the wire also changes.

The temperature of the wire is kept the same.

Which graph shows how the p.d. and current are related?

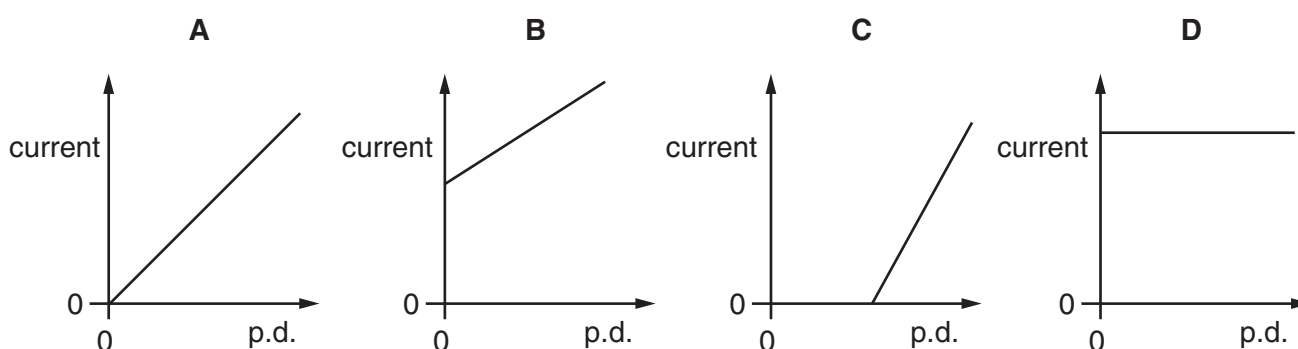

- 38 Two faulty ammeters and two perfect ammeters are connected in series in the circuit.

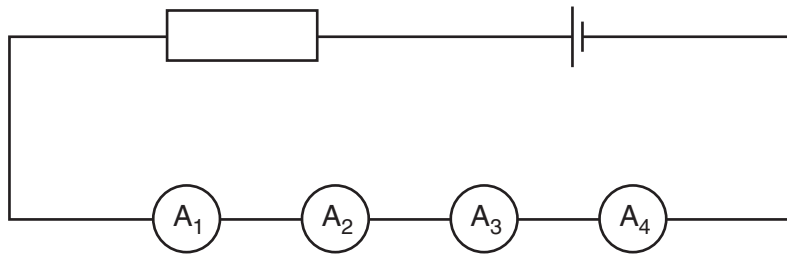

The readings on the ammeters are

$$A_1 \quad 2.9 \text{ A}$$

$$A_2 \quad 3.1 \text{ A}$$

$$A_3 \quad 3.1 \text{ A}$$

$$A_4 \quad 3.3 \text{ A}$$

Which two ammeters are faulty?

- A** A_1 and A_2 **B** A_1 and A_4 **C** A_2 and A_3 **D** A_3 and A_4
- 39 Which type of radiation can be stopped by a sheet of paper?
- A** α -particles
B β -particles
C γ -rays
D X-rays
- 40 The half-life of a radioactive substance is 5 hours. A sample is tested and found to contain 0.48 g of the substance.

How much of the substance was present in the sample 20 hours before the sample was tested?

- A** 0.03 g
B 0.12 g
C 1.92 g
D 7.68 g

DATA SHEET

The Periodic Table of the Elements

Group																		
I	II											III	IV	V	VI	VII	0	
												1 H Hydrogen 1						4 He Helium 2
7 Li Lithium	9 Be Beryllium 4											11 B Boron 5	12 C Carbon 6	14 N Nitrogen 7	16 O Oxygen 8	19 F Fluorine 9	20 Ne Neon 10	
23 Na Sodium	24 Mg Magnesium 12											27 Al Aluminium 13	28 Si Silicon 14	31 P Phosphorus 15	32 S Sulphur 16	35.5 Cl Chlorine 17	40 Ar Argon 18	
39 K Potassium	40 Ca Calcium 20	45 Sc Scandium 21	48 Ti Titanium 22	51 V Vanadium 23	52 Cr Chromium 24	55 Mn Manganese 25	56 Fe Iron 26	59 Co Cobalt 27	59 Ni Nickel 28	64 Cu Copper 29	65 Zn Zinc 30	70 Ga Gallium 31	73 Ge Germanium 32	75 As Arsenic 33	79 Se Selenium 34	80 Br Bromine 35	84 Kr Krypton 36	
85 Rb Rubidium 38	88 Sr Strontium 39	89 Y Yttrium 40	91 Zr Zirconium 41	93 Nb Niobium 42	96 Mo Molybdenum 43	98 Tc Technetium 43	101 Ru Ruthenium 44	103 Rh Rhodium 45	106 Pd Palladium 46	108 Ag Silver 47	112 Cd Cadmium 48	115 In Indium 49	119 Sn Tin 50	122 Sb Antimony 51	128 Te Tellurium 52	127 I Iodine 53	131 Xe Xenon 54	
133 Cs Caesium 56	137 Ba Barium 57	139 La Lanthanum 57	178 Hf Hafnium 72	181 Ta Tantalum 73	184 W Tungsten 74	186 Re Rhenium 75	190 Os Osmium 76	192 Ir Iridium 77	195 Pt Platinum 78	197 Au Gold 79	201 Hg Mercury 80	204 Tl Thallium 81	207 Pb Lead 82	209 Bi Bismuth 83	210 Po Polonium 84	210 At Astatine 85	210 Rn Radon 86	
Fr Francium 88	226 Ra Radium 88	227 Ac Actinium 89																
3-71 Lanthanoid series 90-103 Actinoid series																		
		140 Ce Cerium 58	141 Pr Praseodymium 59	144 Nd Neodymium 60	147 Pm Promethium 61	150 Sm Samarium 62	152 Eu Europium 63	157 Gd Gadolinium 64	159 Tb Terbium 65	162 Dy Dysprosium 66	165 Ho Holmium 67	167 Er Erbium 68	169 Tm Thulium 69	173 Yb Ytterbium 70	175 Lu Lutetium 71			
		232 Th Thorium 90	234 Pa Protactinium 91	238 U Uranium 92	237 Np Neptunium 93	244 Pu Plutonium 94	247 Am Americium 95	251 Cm Curium 96	252 Bk Berkelium 97	259 Cf Californium 98	264 Es Einsteinium 99	267 Fm Fermium 100	271 Md Mendelevium 101	277 No Nobelium 102	286 Lr Lawrencium 103			

20

a	a = relative atomic mass
X	X = atomic symbol
b	b = proton (atomic) number

The volume of one mole of any gas is 24 dm³ at room temperature and pressure (r.t.p.).

