

Centre Number	Index Number	Name
---------------	--------------	------

CAMBRIDGE INTERNATIONAL EXAMINATIONS  
International General Certificate of Secondary Education

**CO-ORDINATED SCIENCES**

**0654/03**

Paper 3

May/June 2003

**2 hours**

Candidates answer on the Question Paper.  
No Additional Materials are required.

**READ THESE INSTRUCTIONS FIRST**

Write your Centre number, candidate number and name on all the work you hand in.  
Write in dark blue or black pen in the spaces provided on the Question Paper.  
You may use a soft pencil for any diagrams, graphs, tables or rough working.  
Do not use staples, paper clips, highlighters, glue or correction fluid.

Answer **all** questions.

At the end of the examination, fasten all your work securely together.

The number of marks is given in brackets [ ] at the end of each question or part question.

A copy of the Periodic Table is printed on page 24.

For Examiner's Use	
1	
2	
3	
4	
5	
6	
7	
8	
9	
10	
<b>Total</b>	

If you have been given a label, look at the details. If any details are incorrect or missing, please fill in your correct details in the space given at the top of this page.

Stick your personal label here, if provided.

1 (a) Fig. 1.1 shows a flower which is pollinated by insects.



Fig. 1.1

(i) On Fig. 1.1, draw label lines to each of the following:

- a place where pollen grains are made, and label it **M**
- a place where pollen grains are deposited, and label it **D**. [2]

(ii) Describe two structures, visible in Fig. 1.1, which indicate that this is an insect-pollinated flower and not a wind-pollinated flower.

1. ....  
.....
2. ....  
..... [2]

(iii) Explain the difference between **pollination** and **fertilisation** in a flower.

- .....  
 .....  
 .....  
 ..... [3]

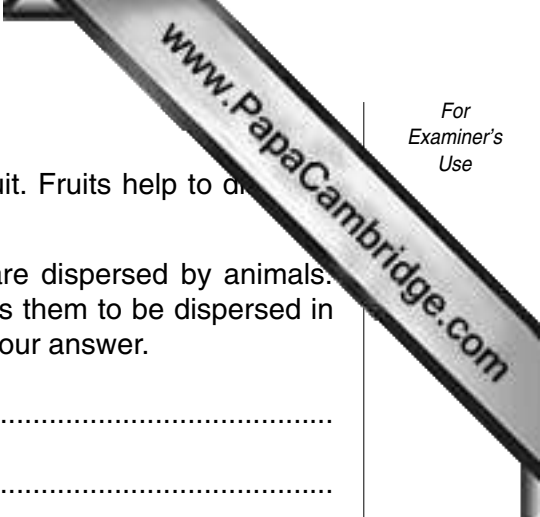

(b) After fertilisation, the ovule develops into a seed inside a fruit. Fruits help to disperse seeds.

(i) **Name** one example of a plant whose fruits or seeds are dispersed by animals. Describe how the structure of these fruits or seeds helps them to be dispersed in this way. You may draw a labelled diagram if this helps your answer.

.....  
.....  
.....

[2]

(ii) Outline two ways in which fruit or seed dispersal is advantageous to plants.

1. ....  
.....  
2. ....  
.....

[2]

2 (a) A 30 dm<sup>3</sup> steel cylinder contained air at atmospheric pressure.

Another 100 dm<sup>3</sup> of air, which had also been at atmospheric pressure, was pumped into the cylinder. Atmospheric pressure is 100 000 N/m<sup>2</sup>.

(i) State the total volume of air at atmospheric pressure before compression.

..... [1]

(ii) Calculate the final pressure of the air inside the cylinder.

Show your working and state any formula that you use.

..... [2]

(iii) When the pressure in the cylinder was actually measured it was found to be 450 000 N/m<sup>2</sup>.

Suggest why this value is different from the value you calculated in (ii).

.....  
.....  
.....  
..... [2]

(b) Fig. 2.1 shows a heat sensor. The plate activates the alarm when the sensor gets hot.

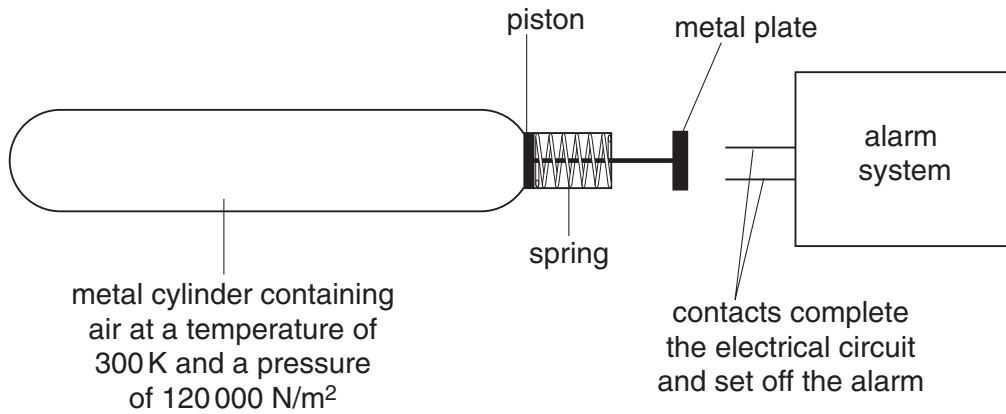

**Fig. 2.1**

(i) Suggest how this sensor works.

.....

.....

.....

..... [3]

(ii) The pressure in the metal tube is 120 000 N/m<sup>2</sup> at 300 K.

A pressure of 180 000 N/m<sup>2</sup> is required to activate the alarm.

Calculate the minimum temperature, in K, at which the alarm is activated.

Show your working and state any formula that you use.

..... [2]

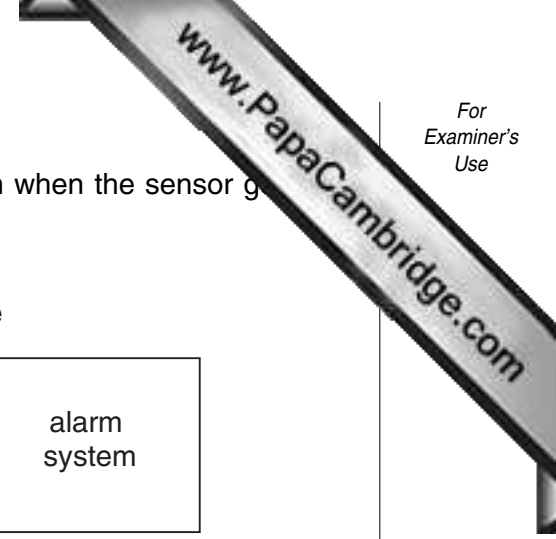

- 3 Fig. 3.1 shows apparatus used to record both temperature and pH during a neutralisation reaction between hydrochloric acid and potassium hydroxide.

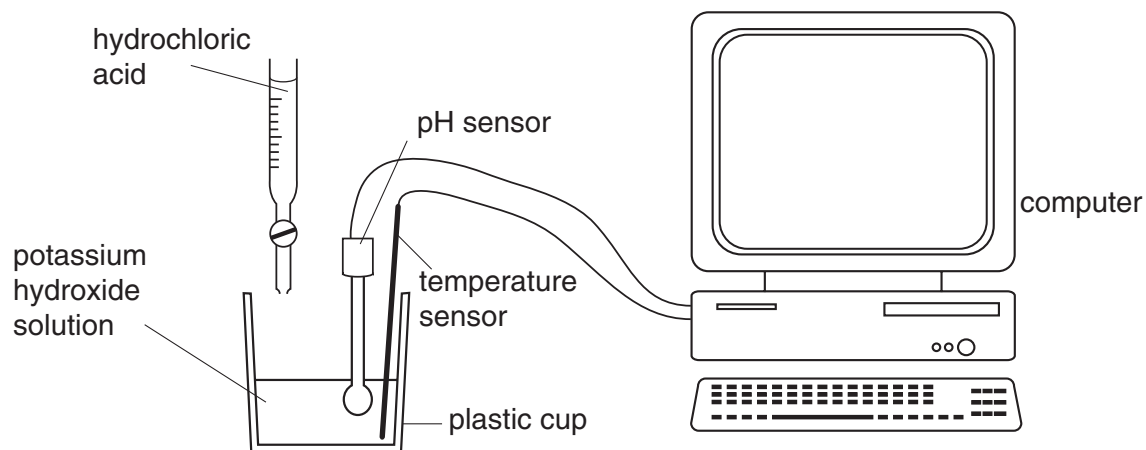

Fig. 3.1

Fig. 3.2 shows the display on the computer screen at the end of the experiment.

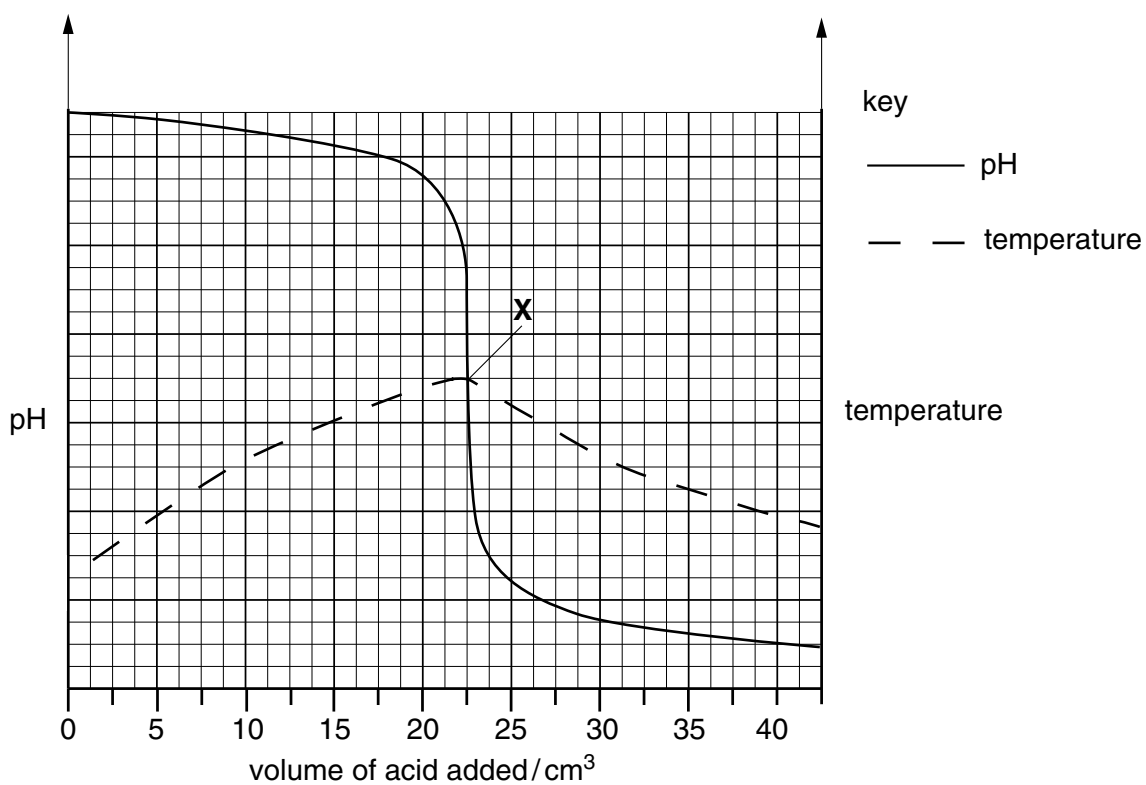

Fig. 3.2

- (a) (i) State the evidence shown on the screen that neutralisation is an exothermic reaction.

.....  
 .....  
 ..... [2]

- (ii) Predict and explain the value of pH at the point X.

.....  
 .....  
 ..... [2]

- (iii) Use the information in Fig. 3.2 to find the volume of hydrochloric acid which just neutralised the potassium hydroxide solution.

..... [1]

- (b) (i) Write a balanced equation for the reaction between hydrochloric acid and potassium hydroxide.

..... [2]

- (ii) State the **two** ions which react together in a neutralisation reaction to form water molecules.

..... [2]

- (c) (i) Calculate the mass of 0.1 mol of potassium hydroxide.

Show your working and state the unit.

..... [2]

- (ii) Calculate the mass of potassium hydroxide which must be dissolved in  $0.25 \text{ dm}^3$  of water to make a solution whose concentration is  $0.1 \text{ mol/dm}^3$ .

Show your working and state the unit.

..... [2]

4 (a) (i) Complete Fig. 4.1 to show the composition of inspired and expired air.

gas	percentage in inspired air	percentage in expired air
carbon dioxide	0.03	
oxygen		18
nitrogen	78	

Fig. 4.1

[3]

(ii) Name **one** other gas which is always present in unpolluted air.

..... [1]

(b) A 30 year old man volunteered to take part in an investigation into the effect of carbon dioxide concentration on his rate of breathing. He sat quietly in an enclosed chamber in which the composition of the air could be controlled. Each time the composition of the air was altered, the investigators waited for 5 minutes before measuring his breathing rate.

The same experiment was repeated with an echidna (a small mammal which lives in Australia) instead of the man. The results of both experiments are shown in Fig. 4.2.

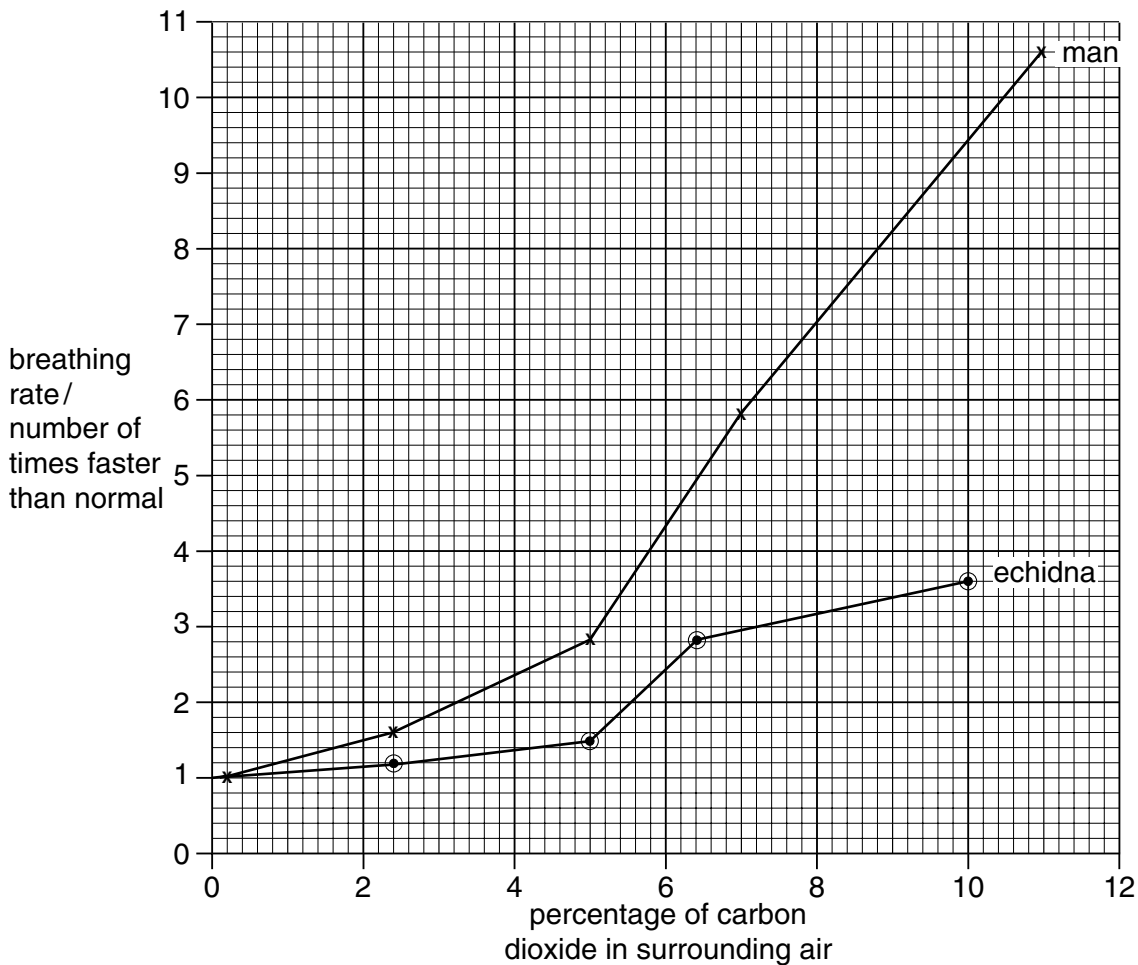



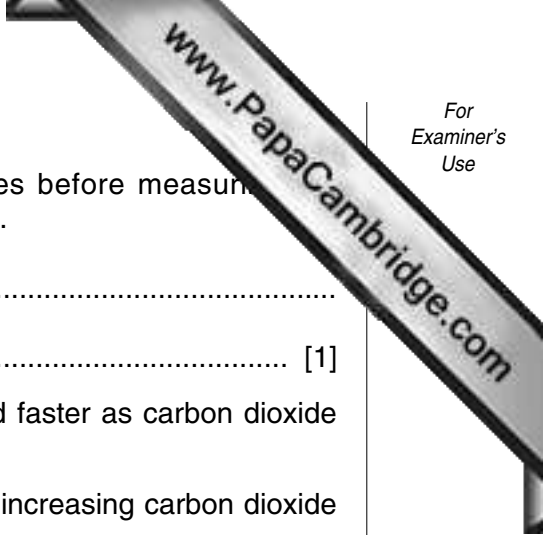

- (i) Suggest why the investigators waited for five minutes before measuring breathing rate in each new carbon dioxide concentration.

.....  
 ..... [1]

- (ii) Fig. 4.2 shows that both the man and echidna breathed faster as carbon dioxide concentration increased.

Give two ways in which the response of the echidna to increasing carbon dioxide concentration is different from the response of the man.

- 1. ....  
 .....
- 2. ....  
 ..... [2]

- (c) The brain actually detects the concentration of carbon dioxide in the blood, not the concentration in the air. When the concentration of carbon dioxide in the air increases, so does the concentration of carbon dioxide in the blood.

- (i) With reference to gas exchange in the lungs, explain why the concentration of carbon dioxide in the air affects the concentration of carbon dioxide in the blood.

.....  
 ..... [2]

- (ii) Suggest why it is useful for the breathing rate to increase when the concentration of carbon dioxide in the blood increases.

.....  
 ..... [2]

- (d) Complete the statements for the boxes with dotted lines to show the major vessels and the parts of the heart through which a carbon dioxide molecule will pass as it travelled from a muscle towards the lungs.

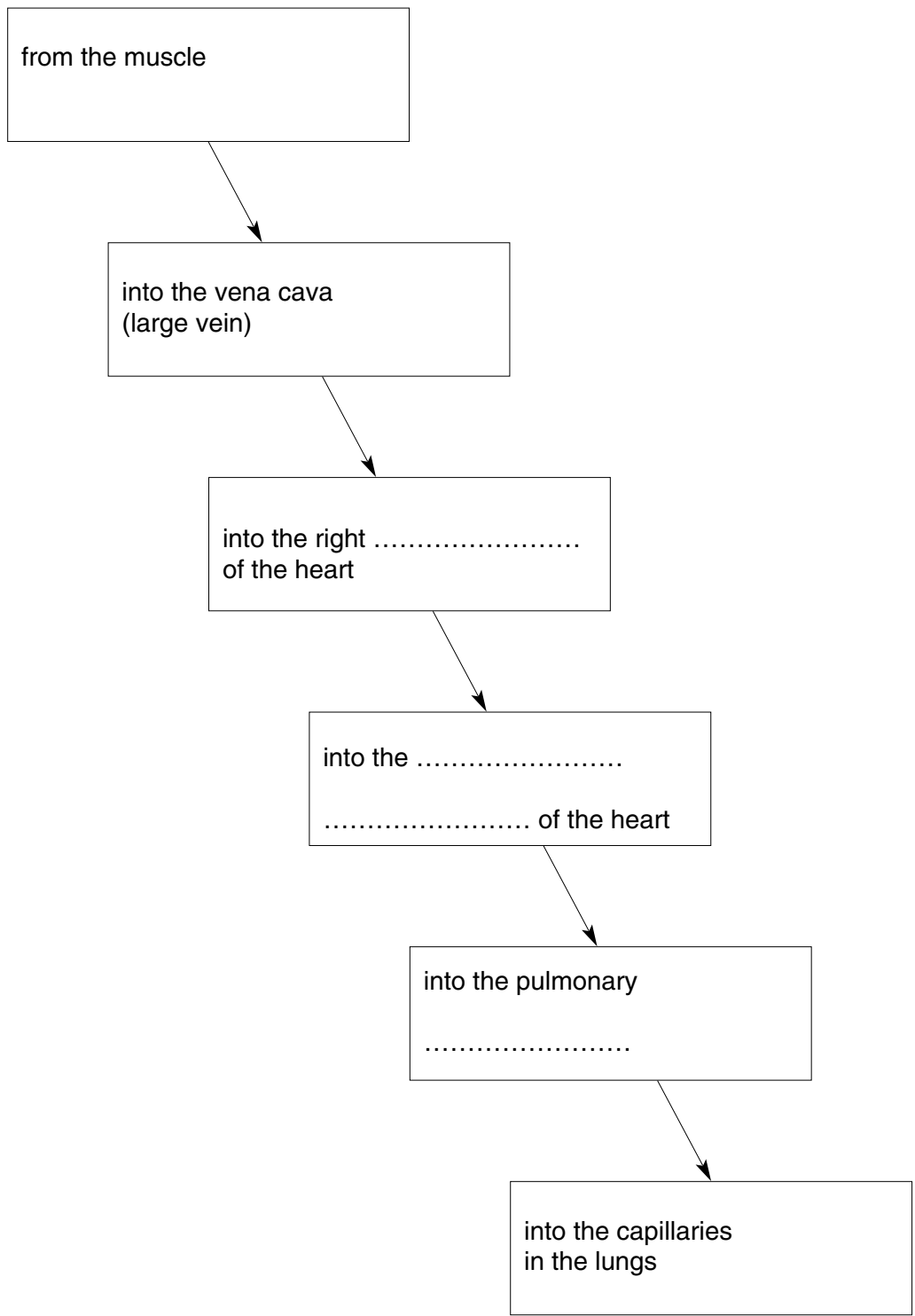

[4]

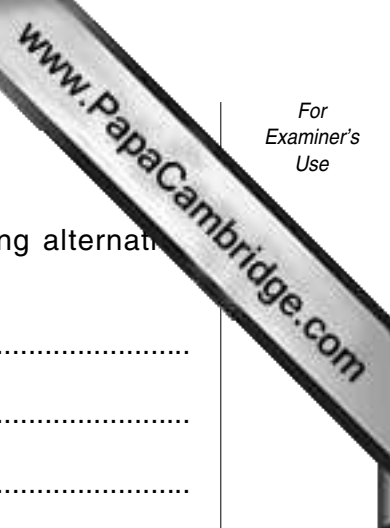

5 (a) Many power stations burn fossil fuels to generate electricity.

(i) Give two reasons why scientists and engineers are developing alternative methods of producing electricity that do not use fossil fuels.

- 1. ....  
.....
- 2. ....  
..... [2]

(ii) Give **one** disadvantage of nuclear power stations compared to power stations that burn fossil fuels.

.....  
..... [1]

(iii) Give **one** disadvantage of using wind turbines to generate electricity compared to power stations that burn fossil fuels.

.....  
..... [1]

(b) Transformers alter the voltage of the electricity generated at a power station.

(i) Explain why this is done.

.....  
.....  
..... [2]

(ii) A transformer at a power station steps up the voltage from 25 000 V to 400 000 V. Use the equation  $\frac{V_p}{V_s} = \frac{N_p}{N_s}$  to calculate the ratio of turns on the primary coil to turns on the secondary coil.

.....  
..... [2]

- 6 Ammonia is made industrially by combining nitrogen from the air with hydrogen in the Haber process.

Fig. 6.1 shows a simplified diagram of the reaction vessel in the Haber process.

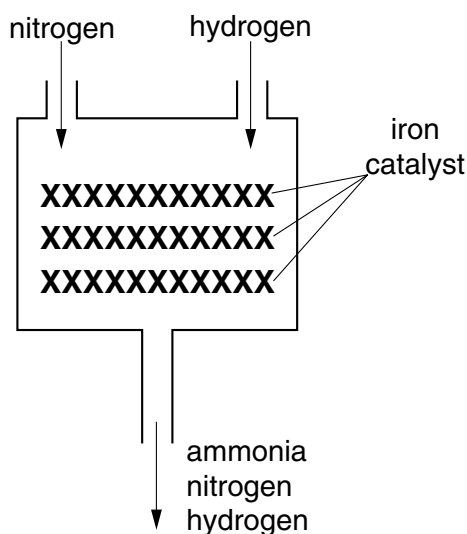

Fig. 6.1

- (a) Describe a chemical test for ammonia.

.....  
 .....  
 ..... [2]

- (b) (i) Suggest a reason why the gas leaving the reactor in Fig. 6.1 is not pure ammonia.

.....  
 ..... [1]

- (ii) Suggest and explain what would happen to the percentage of ammonia if the iron catalyst was not present.

.....  
 .....  
 ..... [2]

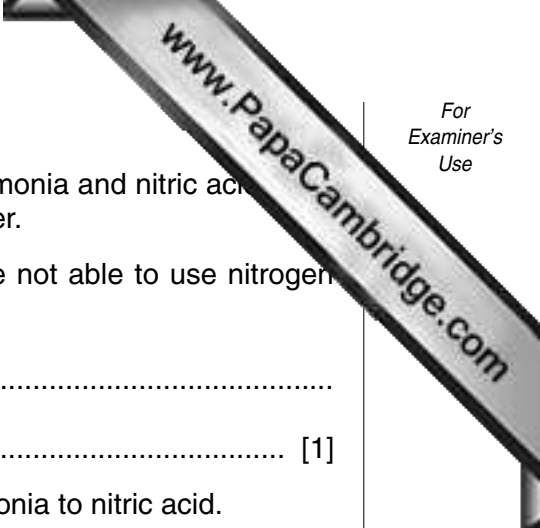

(c) Much ammonia is oxidised to produce nitric acid,  $\text{HNO}_3$ . Ammonia and nitric acid react together to form ammonium nitrate which is used as a fertiliser.

(i) Explain briefly, in terms of its properties, why plants are not able to use nitrogen gas directly.

.....  
..... [1]

(ii) Name **two** substances that are required to convert ammonia to nitric acid.

.....  
..... [2]

(d) Describe how a solution of ammonia could be used to prepare crystals of ammonium sulphate. You should name the other substance required and describe the main steps in the process.

.....  
.....  
.....  
.....  
.....  
.....  
.....  
..... [4]

7 A farmer sprayed fertilisers containing ammonium nitrate onto a field in which young seedlings were growing.

(a) Explain why farmers often add nitrogen-containing fertilisers to the soil where crops are growing.

.....  
.....  
..... [2]

(b) (i) Describe how the ammonium and nitrate ions would be absorbed by the wheat plants.

.....  
.....  
..... [2]

(ii) Name the tissue that would transport the ammonium and nitrate ions through the plant.

..... [1]

(c) Some of the fertiliser was washed into a river which ran alongside the wheat field.

Fig. 7.1 shows how this affected the numbers of bacteria, algae and fish in the river, downstream from the wheat field. It also shows how it affected the oxygen concentration.

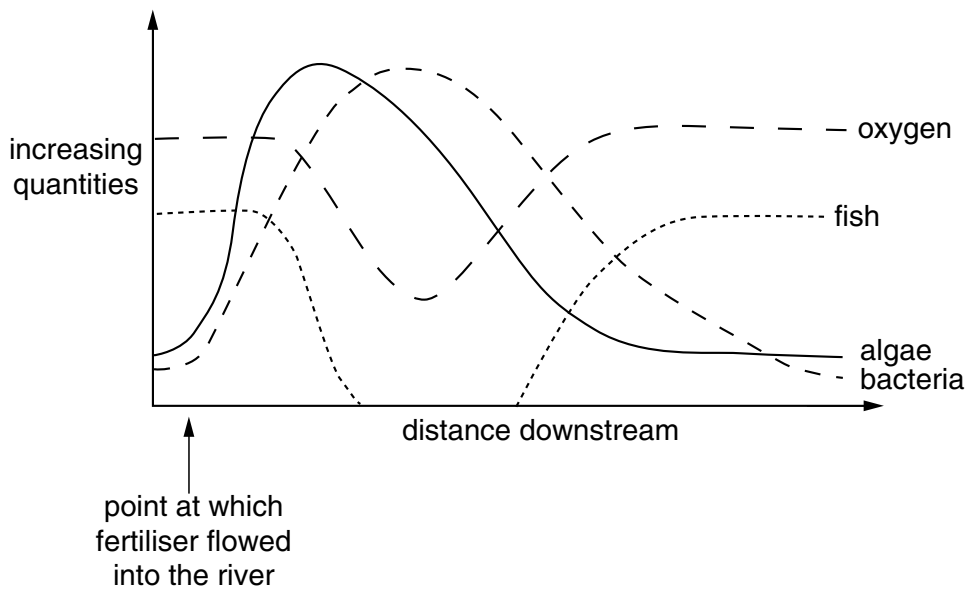
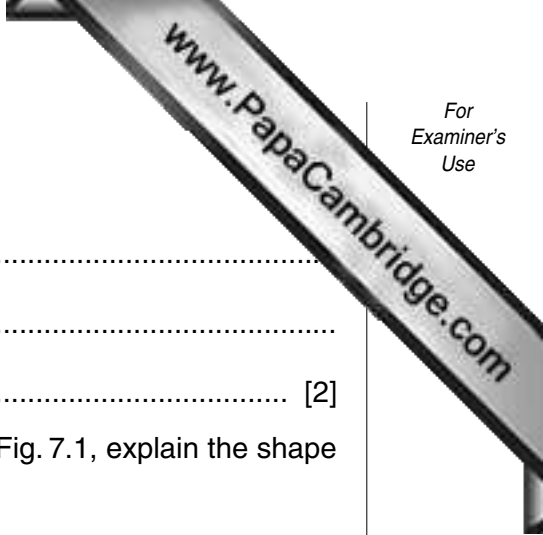

Fig. 7.1



(i) Explain the shape of the curve for the numbers of algae.

.....  
.....  
..... [2]

(ii) With reference to the curves for bacteria and oxygen in Fig. 7.1, explain the shape of the curve for fish.

.....  
.....  
.....  
.....  
..... [4]

- 8 (a) Fig. 8.1 shows the electrical circuit inside a device that can circulate air around a room. It can also be used to heat this air.

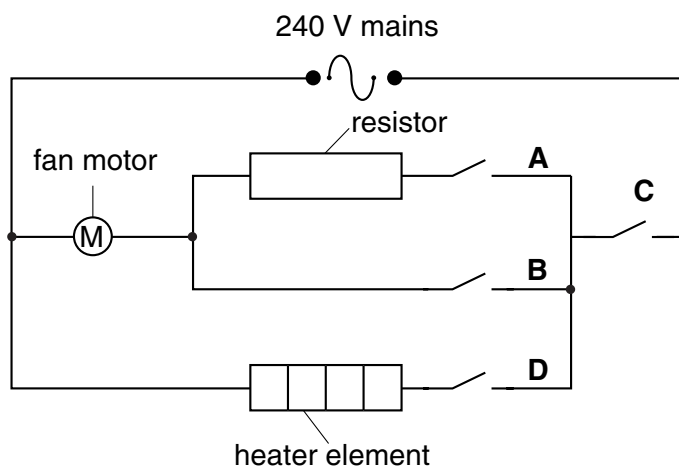

Fig. 8.1

The fan motor must be switched on to blow air.

The heater must be switched on for the air to be warmed.

When the resistor is part of the circuit, the fan motor goes more slowly.

- (i) Complete the table in Fig. 8.2 to show which switches must be on to give the results shown.

result	switch A	switch B	switch C	switch D
cold air, blown slowly	on	off	on	off
hot air, blown slowly				
cold air, blown quickly				
hot air, blown quickly				

Fig. 8.2

[3]

- (ii) Explain why the fan motor goes more slowly when the resistor is part of the circuit.

.....  
 ..... [2]



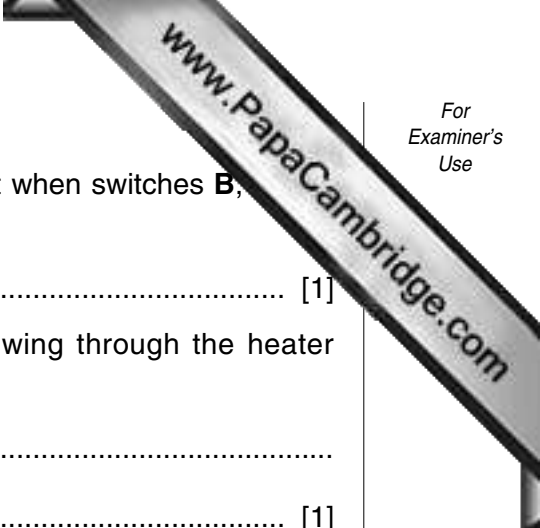

(iii) State the potential difference across the heater element when switches **B**, **D** are all on.

..... [1]

(iv) Explain why, for every coulomb of electric charge flowing through the heater element, 240 joules of heat energy are released.

.....  
..... [1]

(b) A different heater element is used to heat a 2 kg sample of water from 20 °C to 70 °C.

The specific heating capacity of water is 4200 J / kg °C.

Calculate the minimum amount of energy which the heater must have supplied.

Show your working and state any formula that you use.

..... [3]

- 9 A gas fire heats a room by burning methane (natural gas).

When the fire is working properly, the waste gases do not enter the room but leave through a chimney.

- (a) (i) State **one** natural source of methane (natural gas).

.....  
..... [1]

- (ii) Methane has the chemical formula  $\text{CH}_4$ . Draw a dot and cross diagram of a methane molecule showing how the outer electrons are arranged.

[2]

- (iii) Propane is an alkane which has three carbon atoms in each of its molecules. Draw the displayed (graphical) formula of a propane molecule.

[2]

- (iv) Complete the **word** equation for the complete combustion of propane.

propane + oxygen  $\rightarrow$  ..... + .....

[2]

(b) Sometimes the chimney of a gas fire can become blocked, and waste containing carbon monoxide, CO, can escape into the room. Carbon monoxide is a colourless gas which has no odour.

(i) The symbolic equation for the incomplete combustion of methane is shown below. This equation is not balanced.

Balance the equation.



(ii) Carbon monoxide detectors have a coloured spot which becomes darker when carbon monoxide is present in the air.

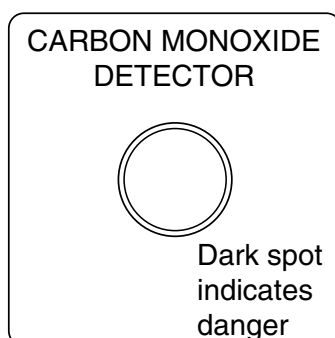

The coloured spot contains palladium chloride,  $\text{PdCl}_2$ .

The charge of a chloride ion is  $\text{Cl}^-$ . Deduce the charge of a palladium ion. Explain your answer.

.....  
 .....  
 ..... [2]

(iii) Suggest why it is advisable to place a carbon monoxide detector in a room which is heated by a gas fire.

.....  
 .....  
 .....  
 ..... [2]



- 10 (a) (i) A car travelling at 60 km/h has four times the kinetic energy of the same car travelling at 30 km/h.

Explain this by means of a calculation.

[2]

- (ii) Use your answer to (i) to explain why the speed of a car involved in an accident with a pedestrian makes such a big difference to the injuries caused.

.....  
 .....  
 ..... [2]

- (b) A car of mass 1000 kg is travelling along a road. The driver applies the brakes which give a constant force of 4000 N.

- (i) Calculate the deceleration of the car.

Show your working and state any formula that you use.

..... [2]

- (ii) The car took 32 metres to stop.

Use the formula

$$\text{distance} = \frac{1}{2}at^2$$

to calculate the time taken to stop.

..... [2]







## DATA SHEET

### The Periodic Table of the Elements

Group																				
I	II											III	IV	V	VI	VII	0			
												1 <b>H</b> Hydrogen 1								4 <b>He</b> Helium 2
7 <b>Li</b> Lithium	9 <b>Be</b> Beryllium 4											11 <b>B</b> Boron 5	12 <b>C</b> Carbon 6	14 <b>N</b> Nitrogen 7	16 <b>O</b> Oxygen 8	19 <b>F</b> Fluorine 9	20 <b>Ne</b> Neon 10			
23 <b>Na</b> Sodium	24 <b>Mg</b> Magnesium 12											27 <b>Al</b> Aluminium 13	28 <b>Si</b> Silicon 14	31 <b>P</b> Phosphorus 15	32 <b>S</b> Sulphur 16	35.5 <b>Cl</b> Chlorine 17	40 <b>Ar</b> Argon 18			
39 <b>K</b> Potassium 20	40 <b>Ca</b> Calcium 21	45 <b>Sc</b> Scandium 22	48 <b>Ti</b> Titanium 23	51 <b>V</b> Vanadium 24	52 <b>Cr</b> Chromium 25	55 <b>Mn</b> Manganese 26	56 <b>Fe</b> Iron 27	59 <b>Co</b> Cobalt 28	59 <b>Ni</b> Nickel 29	64 <b>Cu</b> Copper 30	65 <b>Zn</b> Zinc 31	70 <b>Ga</b> Gallium 32	73 <b>Ge</b> Germanium 33	75 <b>As</b> Arsenic 34	79 <b>Se</b> Selenium 35	80 <b>Br</b> Bromine 36	84 <b>Kr</b> Krypton 36			
85 <b>Rb</b> Rubidium 38	88 <b>Sr</b> Strontium 39	89 <b>Y</b> Yttrium 40	91 <b>Zr</b> Zirconium 41	93 <b>Nb</b> Niobium 42	96 <b>Mo</b> Molybdenum 43	98 <b>Tc</b> Technetium 44	101 <b>Ru</b> Ruthenium 45	103 <b>Rh</b> Rhodium 46	106 <b>Pd</b> Palladium 47	108 <b>Ag</b> Silver 48	112 <b>Cd</b> Cadmium 49	115 <b>In</b> Indium 50	119 <b>Sn</b> Tin 51	122 <b>Sb</b> Antimony 52	128 <b>Te</b> Tellurium 53	127 <b>I</b> Iodine 54	131 <b>Xe</b> Xenon 54			
133 <b>Cs</b> Caesium 56	137 <b>Ba</b> Barium 57	139 <b>La</b> Lanthanum 72	178 <b>Hf</b> Hafnium 73	181 <b>Ta</b> Tantalum 74	184 <b>W</b> Tungsten 75	186 <b>Re</b> Rhenium 76	190 <b>Os</b> Osmium 77	192 <b>Ir</b> Iridium 78	195 <b>Pt</b> Platinum 79	197 <b>Au</b> Gold 80	201 <b>Hg</b> Mercury 81	204 <b>Tl</b> Thallium 82	207 <b>Pb</b> Lead 83	209 <b>Bi</b> Bismuth 84	210 <b>Po</b> Polonium 85	210 <b>At</b> Astatine 86	210 <b>Rn</b> Radon 86			
87 <b>Fr</b> Francium 88	226 <b>Ra</b> Radium 89	227 <b>Ac</b> Actinium 89																		

140 <b>Ce</b> Cerium 58	141 <b>Pr</b> Praseodymium 59	144 <b>Nd</b> Neodymium 60	147 <b>Pm</b> Promethium 61	150 <b>Sm</b> Samarium 62	152 <b>Eu</b> Europium 63	157 <b>Gd</b> Gadolinium 64	159 <b>Tb</b> Terbium 65	162 <b>Dy</b> Dysprosium 66	165 <b>Ho</b> Holmium 67	167 <b>Er</b> Erbium 68	169 <b>Tm</b> Thulium 69	173 <b>Yb</b> Ytterbium 70	175 <b>Lu</b> Lutetium 71
232 <b>Th</b> Thorium 90	234 <b>Pa</b> Protactinium 91	238 <b>U</b> Uranium 92	237 <b>Np</b> Neptunium 93	244 <b>Pu</b> Plutonium 94	247 <b>Am</b> Americium 95	251 <b>Cm</b> Curium 96	252 <b>Bk</b> Berkelium 97	257 <b>Cf</b> Californium 98	261 <b>Es</b> Einsteinium 99	267 <b>Fm</b> Fermium 100	271 <b>Md</b> Mendelevium 101	277 <b>No</b> Nobelium 102	289 <b>Lr</b> Lawrencium 103

57-71 Lanthanoid series  
80-103 Actinoid series

a	a = relative atomic mass
<b>X</b>	X = atomic symbol
b	b = proton (atomic) number

The volume of one mole of any gas is 24 dm<sup>3</sup> at room temperature and pressure (r.t.p.).